

**Fluid Loss Test Instrument**  
**Single Cell**  
**Instruction Manual**



**Instruction Manual No. 100020420, Revision D**

**Instrument No. 101502980, Single Cell, 115 volt**

**Instrument No. 101533370, Single Cell, 230 volt**

## Single Cell Fluid Loss Test Instrument

©2014 Fann Instrument Company

Houston, Texas, USA

All rights reserved. No part of this work covered by the copyright hereon may be reproduced or copied in any form or by any means (graphic, electronic, or mechanical) without first receiving the written permission of Fann Instrument Company, Houston, Texas, USA.

Printed in USA.

The information contained in this document includes concepts, methods, and apparatus which may be covered by U.S. Patents. FANN® reserves the right to make improvements in design, construction, and appearance of our products without prior notice.

FANN® and the FANN logo are registered trademarks of Fann Instrument Company in the United States and/or other countries. Micro Matrix® is a registered trademark of Halliburton Energy Services, Inc. in the United States and/or other countries. All other trademarks mentioned in the operating instructions are the exclusive property of the respective manufacturers.

### Contact FANN



#### Phone

TELEPHONE: 281-871-4482

TOLL FREE: 800-347-0450

FAX: 281-871-4358



#### Mail

Fann Instrument Company

P.O. Box 4350

Houston, Texas, 77210 USA



#### Location

Fann Instrument Company

14851 Milner Road, Gate 5

Houston, Texas, 77032, USA



#### Online

[www.fann.com](http://www.fann.com)

[fanmail@fann.com](mailto:fanmail@fann.com)

## Table of Contents

1	Introduction to the Fluid Loss Test Instrument .....	6
1.1	Document Conventions .....	7
2	Safety .....	8
2.1	Safe Pressurization.....	8
2.2	Safe Heating.....	9
2.3	Safe Electrical Operation .....	10
2.4	Safe Reservoir Maintenance.....	10
3	Features and Specifications.....	11
3.1	Fluid Loss Mechanical .....	12
3.2	Fluid Loss Controls and Indicators.....	12
3.3	Pressure .....	12
3.4	Timer .....	13
4	Installation .....	14
4.1	Fluid Loss Test Instrument Installation.....	14
4.2	Heating Jacket.....	14
4.3	Pressurizing System .....	14
4.4	Tools.....	14
4.5	Consumables.....	14
5	Operation.....	15
5.1	Preparing the Fluid Loss Reservoir .....	18
5.2	Preheating the Heating Jacket and Reservoir .....	23
5.3	Setting the first time alarm on the timer.....	27
5.4	Conditioning the Slurry .....	28
5.5	Loading the Fluid Loss Reservoir.....	28
5.6	Setting the Test Pressure .....	31
5.7	Starting the Fluid Loss Test .....	32
5.8	Stopping the Fluid Loss Test .....	33
5.9	Storing the Reservoir .....	35
6	Test Analysis .....	36
6.1	References .....	36
6.2	Results .....	36
6.3	Variations .....	36
6.4	Filtrate Volume .....	37
6.5	Calculations .....	37

6.6	Reporting.....	37
7	Troubleshooting and Maintenance.....	38
7.1	Fluid loss reservoir maintenance .....	38
7.2	Pressurization systems.....	39
7.3	Pressurization system troubleshooting.....	40
7.4	Faulty pressure regulator.....	40
7.5	Pressure regulator repair .....	40
7.6	Temperature controller troubleshooting .....	40
7.7	Heater element troubleshooting .....	41
7.8	Heating jacket removal .....	42
7.9	Heating element replacement .....	43
7.10	Heating jacket re-mount.....	44
8	Accessories .....	46
9	Parts List.....	47
10	Warranty and Returns.....	54
10.1	Warranty.....	54
10.2	Returns.....	54

## **List of Figures**

Figure 3-1	Single Cell Fluid Loss Test Instrument.....	12
Figure 5-1	Reservoir components.....	16
Figure 5-2	Temperature controller .....	16
Figure 5-3	Major frame components .....	17
Figure 5-4	O-ring in reservoir bottom .....	18
Figure 5-5	Filter Screen (325 on left, 600 on right).....	18
Figure 5-6	Screen and O-ring in reservoir bottom .....	19
Figure 5-7	Plain cap (left) and grooved cap (right) .....	19
Figure 5-8	How to install the bottom (grooved) reservoir cap.....	20
Figure 5-9	How to align reservoir in reservoir stand.....	20
Figure 5-10	How to tighten bottom cap with reservoir wrench.....	21
Figure 5-11	How to tighten bottom valve with adjustable wrench.....	21
Figure 5-12	O-rings (2) and brass backup ring in reservoir top .....	22
Figure 5-13	How to install top reservoir cap.....	22
Figure 5-14	How to tighten top valve with adjustable wrench.....	23
Figure 5-15	Top and bottom valves closed .....	23

Figure 5-16	Heating Jacket Thermocouple plugs on left side of the instrument .....	24
Figure 5-17	Cell Thermocouple partially inserted in reservoir .....	24
Figure 5-18	Reservoir in heating jacket for pre-heating .....	25
Figure 5-19	Amount of slurry .....	29
Figure 5-20	Tighten top cap with wrenches .....	29
Figure 5-21	Hand nut tightened to valve head assembly .....	30
Figure 5-22	Graduated cylinder below bottom valve .....	30
Figure 5-23	Top reservoir valve (closed on left, open on right) .....	31
Figure 5-24	Pressure Gauges and Regulator .....	31
Figure 5-25	Pressure Manifold Inlet Valve (closed on left, open on right) .....	32
Figure 5-26	Top reservoir inlet valve (closed on left, open on right).....	32
Figure 5-27	Bottom reservoir outlet valve (closed on left, open on right).....	33
Figure 7-1	Heating jacket bolts .....	42
Figure 7-2	Heating element cover screws.....	43
Figure 7-3	Heating elements and wiring exposed .....	43
Figure 7-4	Heating elements wiring diagrams.....	43
Figure 7-5	Holes to drive out heating elements.....	44
Figure 7-6	Correct height of heating jacket .....	45
Figure 9-1	Wiring Diagram, Single Cell Cement Fluid Loss Tester, 115 VAC .....	48
Figure 9-2	Wiring Diagram, Single Cell Cement Fluid Loss Tester, 230 VAC .....	49
Figure 9-3	Manifold Assembly .....	50
Figure 9-4	Cell Assembly.....	51

## List of Tables

Table 3-1	Single Cell Fluid Loss Test Instrument Specifications.....	11
Table 5-1	Standard API Well Simulation Cement Test Outline .....	15
Table 7-1	Temperature controller problems.....	41
Table 7-2	Heater element measurements .....	42
Table 8-1	Accessories.....	46
Table 9-1	Cement Fluid Loss Tester, Single Cell, 115V, P/N 101502980, Revision M.....	47
Table 9-2	Cement Fluid Loss Tester, Single Cell, 230V, P/N 101533370, Revision M.....	47
Table 9-3	Manifold Assembly, High Pressure, P/N 100020406, Revision D .....	50
Table 9-4	Cell Assembly, Fluid Loss, Short Cell, P/N 101776831, Revision B.....	51
Table 9-5	Basic Unit, 115 VAC and 230 VAC, P/N 101775743, Revision F .....	52

## **1 Introduction to the Fluid Loss Test Instrument**

The Fluid Loss Test Instrument simulates static filtration at downhole conditions in a wellbore. This test determines the volume of fluid loss (filtrate) from cement slurry or a water-based mud at a set temperature and pressure. The test results are used to evaluate fluid-loss control properties.

### **1.1 Pressure Control**

The sample cell (reservoir) may be operated up to 1,500 psi (10.3 MPa) from an external nitrogen (N<sub>2</sub>) source. The desired pressure is maintained during heating by a self-relieving pressure regulator.

### **1.2 Temperature Control**

The fluid loss instrument may be operated at temperatures up to 200°F (93°C). Temperatures above 212°F (100°C) will vaporize the fluid, making the test readings inaccurate. An aluminum heating jacket surrounds the non-ferrous slurry sample cell, assuring filtration at the desired temperature. The power consumption of the cell heating jacket is 1,600 watts.

The heating jacket temperature is measured by a thermocouple (P/N 102357199) and controlled by a PID-type temperature controller. The cell temperature is measured with a thermocouple (P/N 101733741) connected to a handheld digital thermometer.

### **1.3 Filter Cell and Screens**

A 2-1/2 inch (6.35 cm) stainless steel filter screen simulates the formation permeability. Two screens are available - a 325 mesh screen backed by a 60 mesh screen and a 600 mesh screen backed by a 60 mesh screen, both of which are laminated to a perforated stainless steel backing. The 600/60 mesh screen is for testing Micro Matrix<sup>®</sup> cement slurries only.

Valves at top and bottom of the cell are manually opened and closed as necessary to pressurize the cell and to release the fluid during the measurement phase of the test. A graduated cylinder is used to collect the filtrate. A stand mounted on the base plate securely holds the slurry sample cell (reservoir) while the top and bottom lids are being installed or removed.

1.4 Document Conventions

The following icons are used in this manual as necessary.



**NOTE.** Notes emphasize additional information that may be useful to the reader.



**CAUTION.** Describes a situation or practice that requires operator awareness or action in order to avoid undesirable consequences.



**MANDATORY ACTION.** Gives directions that, if not observed, could result in loss of data or in damage to equipment.



**WARNING!** Describes an unsafe condition or practice that if not corrected, could result in personal injury or threat to health.



**ELECTRICITY WARNING!** Alerts the operator that there is risk of electric shock.



**HOT SURFACE!** Alerts the operator that there is a hot surface and that there is risk of getting burned if the surface is touched.



**EXPLOSION RISK!** Alerts the operator that there is risk of explosion.

## **2 Safety**

Safe operation of the Fluid Loss Test Instrument requires the operator understand and practice the correct assembly and operation of the equipment. Improper assembly, operation, or the use of defective parts, poses the possibility of cell leakage or failure, which could result in serious injury and damage.

The reservoir and the heating jacket are hot during operation. The operator should be aware of these hot areas and avoid contact with them. Burns can result from touching hot parts of the equipment during normal operation.

These instruments are electrically heated. As with any electric device, the wiring should be regularly checked for bad connections. These instruments should always be used on a grounded circuit.

Following is a list of suggestions that should be observed to assure safe operation and maintenance of the Fluid Loss Test Instrument.

### **2.1 Safe Pressurization**

Always use nitrogen (N<sub>2</sub>) gas. Never connect the Fluid Loss Test Instrument to compressed air, oxygen or other non-recommended gas. Nitrogen must be supplied in an approved nitrogen gas cylinder or the nitrogen supply system must be built into the laboratory. Nitrogen cylinders must be secured to meet safety standards.

Maintain pressure regulators in good condition. Never use oil on pressure regulators. Leaking pressurizing systems should be repaired or replaced. Gauges, fittings and hoses should be kept in good condition and any leaks should be promptly located and corrected.

When pressurizing the cell, always open the supply pressure first, and then adjust the regulator. Do not attempt to pressurize higher than the equipment is rated. Follow the procedure as outlined in Section 5.6 Setting the Test Pressure. When de-pressurizing, shut off the supply pressure, bleed the system of pressure, and then back out the regulator knob, following the procedures in Section 5.8 Stopping the Fluid Loss Test.

The threaded end caps on the cell assemblies can indicate pressure is trapped inside the cell, such as by a cement plug. If greater than normal force is required to turn a cap for removal, this could indicate that pressure is trapped inside the cell.



## 2.2 Safe Heating

Caution should be exercised by all personnel operating or working near the Fluid Loss Test Instrument while it is in operation to avoid accidental injury.



The heating jacket can operate at a temperature that will cause burns if touched. Safeguard the equipment after the test ends long enough for it to cool. Even after it has been turned off, it can still be hot enough to cause burns.



Removing the cell and cooling it under water is a very dangerous practice. It is not recommended because severe burns can result if the cell is touched. Hot steam or water generated when the water hits the hot cell can cause severe burns.



Wear thermally insulated gloves when handling the cell assembly and removing it from the heating jacket.



Never operate the heating jacket without a thermocouple in the reservoir. Not using a thermocouple will result in loss of temperature feedback and overheating. The overheating could become severe enough to cause melting.

### **2.3 Safe Electrical Operation**

1. Make sure the electrical source is fused and grounded.
2. Verify the power cord on the Fluid Loss Test Instrument is in good condition and that it has the proper ground connection.
3. Electrical problems in the wiring or heaters may not be obvious by looking at the equipment. If the unit blows fuses or trips breakers, the heating time seems longer than normal or the temperature controller does not reliably maintain temperature, then electrical repair may be required. Refer to Sections 7.7 to 7.10 for troubleshooting and repairing the heating jacket and heater elements.



Always disconnect the power cable before making any repairs.

---

### **2.4 Safe Reservoir Maintenance**

The assembled reservoir body, end caps and valves constitute a pressure vessel. These safety precautions should be followed to assure safe operation.

1. The cell body and cap material should be compatible with the test sample.
2. Cell bodies with cracks, severe pitting, or damaged threads must not be used.
3. Cell caps with damaged threads must not be used.

### 3 Features and Specifications

Table 3-1 lists the specifications. The Fluid Loss Test Instrument is available in two configurations. Figure 3-1 shows the single cell style described in this instruction manual. The single cell is available for either 115 or 230 volt, and both will operate on 50 or 60 Hz AC power.

**Table 3-1 Single Cell Fluid Loss Test Instrument Specifications**

<b>Category</b>	<b>Specification</b>
Maximum Temperature	200°F (93°C)
Maximum Pressure	1,500 psi (10.3 MPa)
Slurry Reservoir (1)	
Diameter x Length (excludes valves)	3.25 x 5.12 in ( 8.26 x 13.00 cm)
Volume	9.75 oz (288 mL)
Weight	8.80 lb (4 kg)
Frame	
Width x Depth x Height	18.0 x 16.0 x 25.625 inches (in) 45.7 x 40.6 x 65.08 centimeters (cm)
Weight	78 lb (35 kg)
Pressure Connection	Nitrogen, CGA-584
Voltage and Current	Single phase, AC, 50–60 Hz 115V, 15A, NEMA 5-20P plug or 230V, 10A, NEMA 6-15P plug



**Figure 3-1 Single Cell Fluid Loss Test Instrument**

### **3.1 Fluid Loss Mechanical**

A durable, stainless steel, base plate and frame supports the pressure gauges, pressure regulator, temperature controller, timer, pressure manifold and heating jacket. The heating jacket is attached to an adjustable bracket, allowing easy and efficient insertion and removal of the reservoirs. A simple hand nut couples the reservoir to the pressure manifold without tools. A stand is located at the front of the base plate to hold the reservoir upright when filling and cooling.

### **3.2 Fluid Loss Controls and Indicators**

The desired temperature is regulated by an electronic temperature controller, which senses the temperature through a Type J thermocouple placed in the heating jacket. It controls the temperature by rapidly turning on and off the power applied to the heating jacket heaters. The relationship between the "ON" time and the "OFF" time per cycle determines the temperature.

A manual switch is located on the front panel to enable and disable the heating jacket independent of the temperature controller. This design is both a convenience and safety feature.

### **3.3 Pressure**

Nitrogen is the preferred pressurization gas for fluid loss testing. An inlet nipple and CGA-584 nut is provided at the end of a 5-foot (1.5 meter) long hose. The external nitrogen gas source connects to the panel-mounted, self-relieving, pressure regulator. Separate front panel gauges indicate the pressures of both the supply and output to the frame-mounted pressure manifold, located above the heating jacket and reservoir.



---

Fluid loss tests performed with the provided reservoir should not be performed with pressures exceeding 1,500 psi (10.3 MPa).

---

To increase the output pressure, the pressure regulator knob is rotated clockwise (CW). To decrease the output pressure, the pressure regulator knob is rotated counter-clockwise (CCW). Reducing the regulator output pressure will reduce the pressure in the manifold. It will also reduce the pressure in the reservoir only if the manifold valve above the reservoir is open. Similarly, pressure increases caused by heating will be released through the regulator, only when the manifold valve above the reservoir is open.

### **3.4 Timer**

An electronic timer on the front panel may be used to set a time alarm. An alarm will sound at a preset time alerting lab personnel to record the fluid loss volume according to the test schedule.

## 4 Installation

### 4.1 Fluid Loss Test Instrument Installation

The Fluid Loss Test Instrument can generally be placed to suit the available space and the desires of the lab personnel, consistent with established work processes. Some environments encourage a right-to-left flow, while others a left-to-right. Consideration should be given to the areas where sample preparation and cleanup take place following the test. The pressurizing system may also dictate installation-specific requirements, such as having a large compressed gas cylinder secured nearby. There should be sufficient storage area for commonly used tools and consumable items.

The Single Cell Fluid Loss Test Instrument has a power cord approximately 5 ft (1.5 m) long. It must be located no farther than 5 feet (1.5 meter) from the appropriate electrical outlet. Because of the diversity in types of electrical outlets throughout the world, it may be necessary to replace the power cord's plug. The power cords should be kept away from the un-insulated surface of the heating jacket while the jacket is in use and immediately afterwards.



Customer installed wiring, electrical connectors, and power cords are excluded from the warranty.

---

### 4.2 Heating Jacket

The heating jacket power cord must be connected to the locking receptacle on the bottom side of the cabinet.

### 4.3 Pressurizing System

The pressurizing system may also dictate installation requirements, such as having a large compressed gas cylinder secured nearby. When a compressed gas cylinder is used, it should be located within reach of the tubing attached to the pressure regulator, typically 5 feet (1.5 meter).

### 4.4 Tools

Storage space near the cell preparation area should be provided for the wrenches used to install, tighten, loosen and remove the end caps.

### 4.5 Consumables

Consumables (filter screens and O-rings) should be near the cell preparation area.

**5 Operation**

Before operating this instrument and running your test, review section 10, Static Fluid Loss Test of the API Recommended Practice for Testing Well Cements, API RP 10B-2. Refer to Table 5-1 for a summary of the test.

**Table 5-1 Standard API Well Simulation Cement Test Outline**

<b>TEMPERATURE</b>	190°F (88°C)
<b>PRESSURE</b>	1000 psi ± 50 psi (7000 kPa ± 300 kPa)
<b>SAMPLE PREPARATION</b>	Mix cement per API RP10B-2, Section 5. Process sample in Consistometer. See API RP10B-2, Section 10 Static Fluid Loss Test for filtrate times.
<b>EXPANSION ALLOWANCE</b>	3/4 in. (19.05 mm)
<b>SAMPLE VOLUME</b>	130 mL fluid (175 mL cell capacity)
<b>FILTER</b>	No. 325 (45µm) U S Sieve with 60 mesh backing screen, stainless steel
<b>TIME</b>	Sample Heating - 15 minutes from time pressure is applied Duration of test - 30 minutes Take filtrate volume readings at 30 seconds and 1, 2, 5, 7.5, 10, 15, 25, and 30 minutes after test starts.
<b>FILTRATE COLLECTOR</b>	100 ml graduated cylinder

Before starting the test, the reservoir must be removed from the heating jacket. For easy identification of the major components, refer to Figure 5-1 for the reservoir, Figure 5-2 for the temperature controller, and Figure 5-3 for the frame.

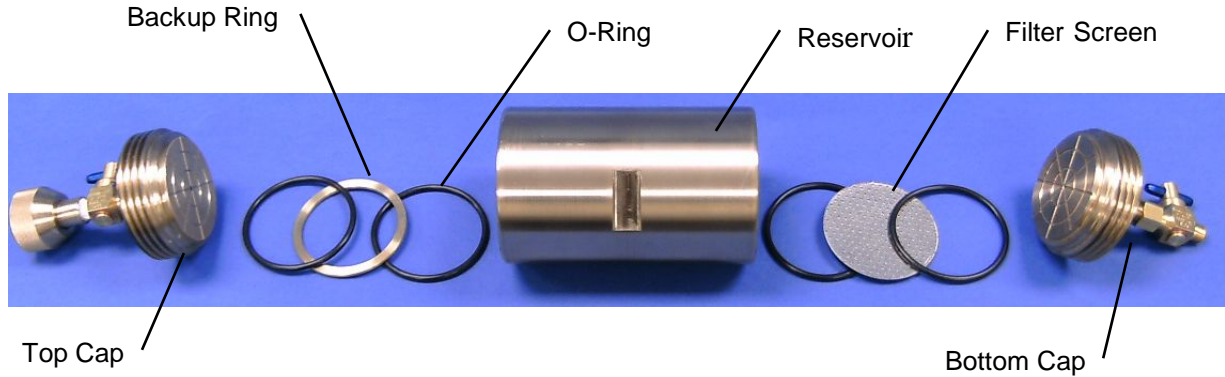
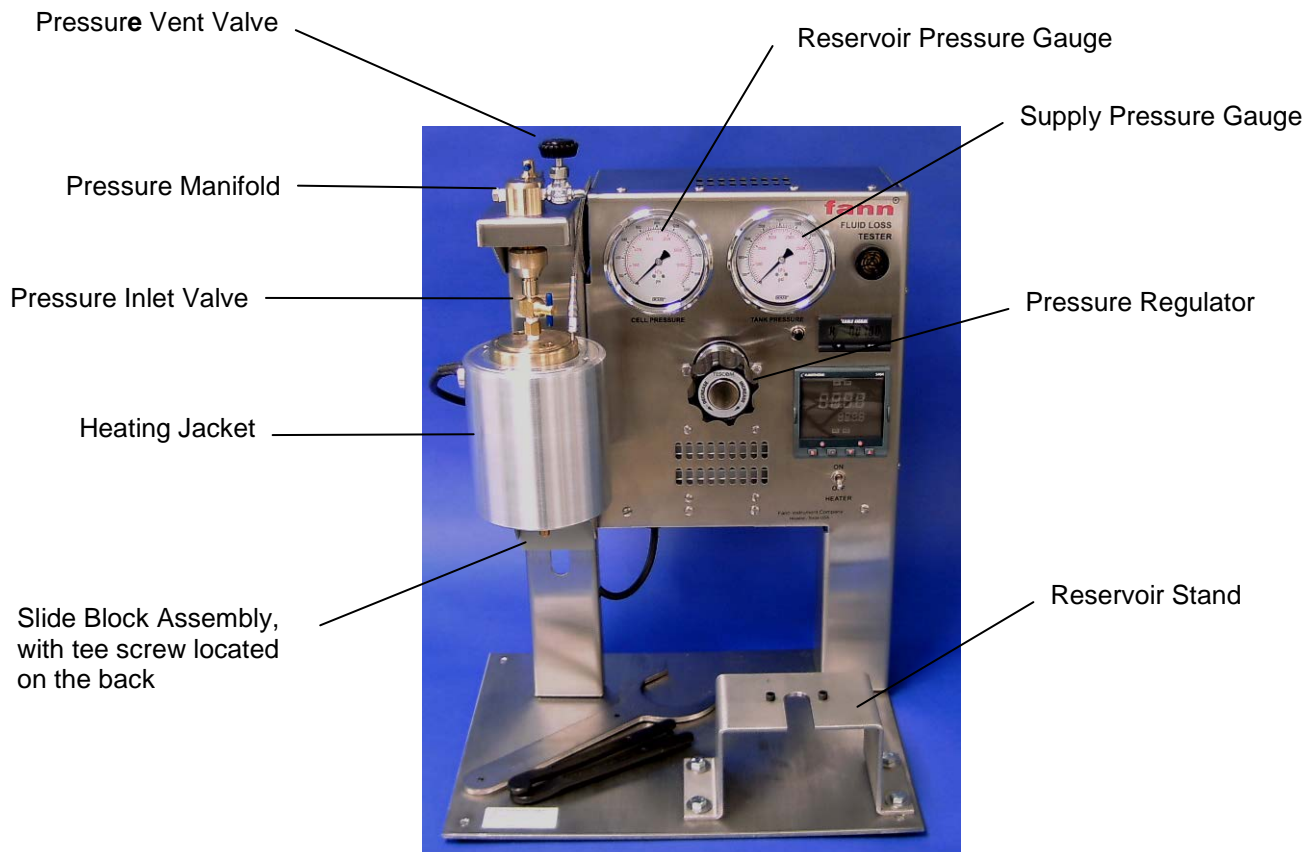

**Figure 5-1 Reservoir components**



**Figure 5-2 Temperature controller**





**Figure 5-3 Major frame components**

### 5.1 Preparing the Fluid Loss Reservoir

1. Inspect the O-rings for damage, cement contamination and brittleness. Remove cement contaminants, and replace damaged or brittle O-rings.
2. Insert an O-ring into the bottom (filter) end of the reservoir.

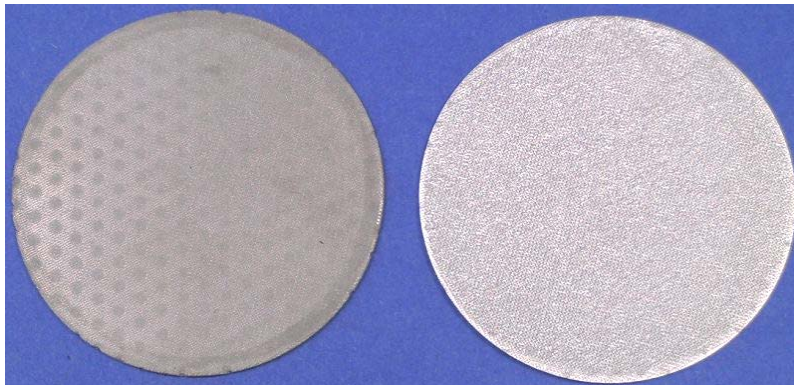

**Figure 5-4 O-ring in reservoir bottom**



The bottom (filter) end of the reservoir does not have a small hole for the thermocouple.

3. Select the desired filter screen (325 or 600 mesh) and place the screened side against the O-ring in the reservoir.



**Figure 5-5 Filter Screen (325 on left, 600 on right)**

4. Place an O-ring against the perforated side of the filter screen.



**Figure 5-6 Screen and O-ring in reservoir bottom**

5. Insert a grooved end cap into the reservoir and hand-tighten it.



---

A grooved cap must be used in the reservoir bottom (filter end).  
A plain or grooved cap may be used in the reservoir top.

---

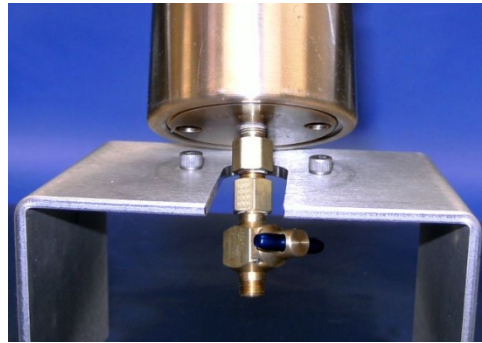

**Figure 5-7 Plain cap (left) and grooved cap (right)**



**Figure 5-8 How to install the bottom (grooved) reservoir cap**

6. Place the reservoir on the reservoir stand, aligning the cap holes with the stand pins.



**Figure 5-9 How to align reservoir in reservoir stand**

7. Place the reservoir wrench on the reservoir flats and fully tighten the cap and reservoir.

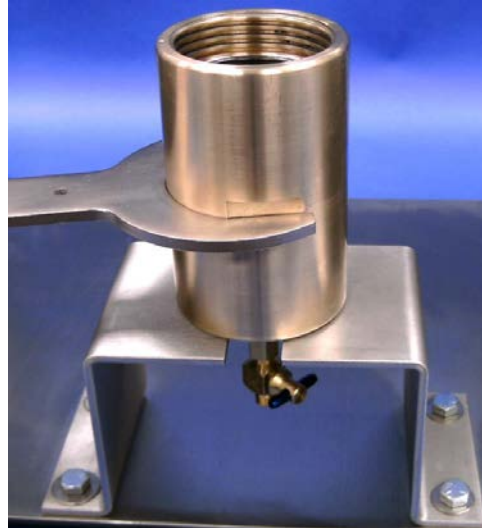

**Figure 5-10** How to tighten bottom cap with reservoir wrench

8. Use an adjustable wrench to check that the valve and adapters are tight in the bottom cap.

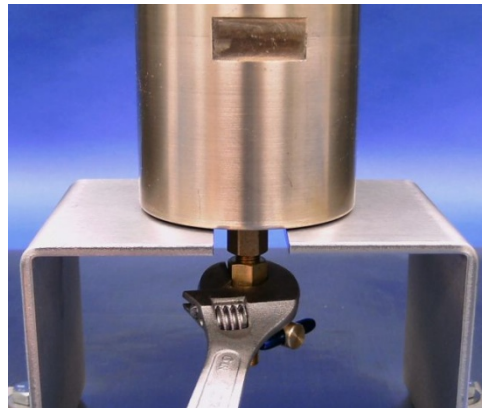

**Figure 5-11** How to tighten bottom valve with adjustable wrench

9. Insert an O-ring into the reservoir top.
10. Place the brass backup ring on top of the O-ring.
11. Place another O-ring against the brass backup ring.

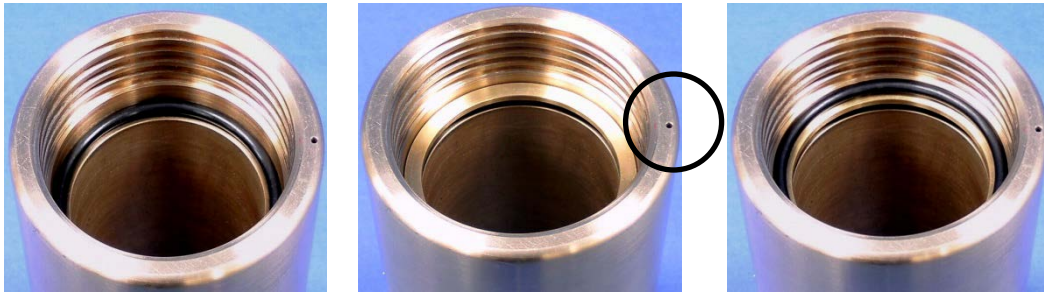
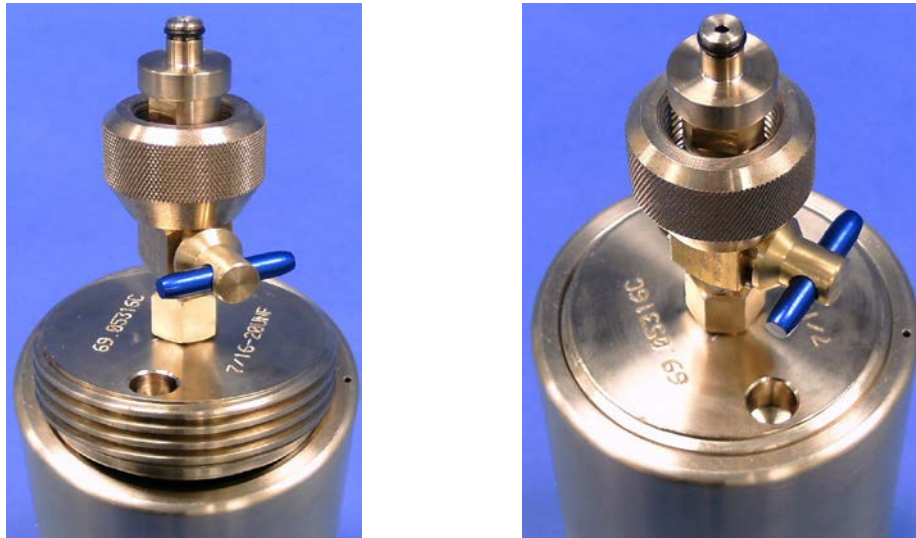

**Figure 5-12 O-rings (2) and brass backup ring in reservoir top**



The reservoir top has a small hole for the thermocouple.

12. Insert a plain (non-grooved) or grooved cap into the reservoir top and tighten it no more than two full turns.



**Figure 5-13 How to install top reservoir cap**

13. Install and tighten a valve adapter, valve, coupling and hand nut into the top cap, using an adjustable wrench. Place the adjustable face spanner wrench in the cap holes to hold it while tightening the valve, valve adapter, and coupling.



Figure 5-14 How to tighten top valve with adjustable wrench

## 5.2 Preheating the Heating Jacket and Reservoir

1. Close the valves in the top and bottom caps.

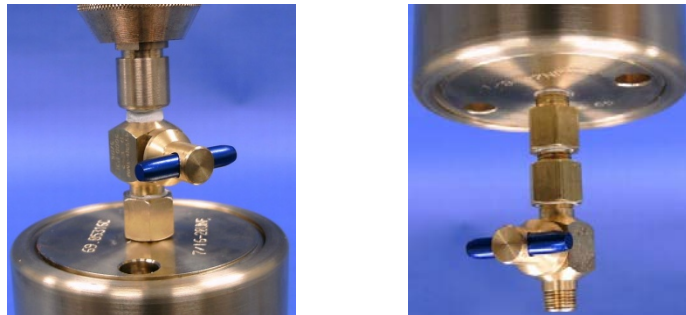

Figure 5-15 Top and bottom valves closed



Do not hold the slurry cylinder near the side wrench slots when placing it into the heating jacket. Your fingers may be cut.

2. Insert the empty fluid loss reservoir into the heating jacket with the non-filter end (the end with the coupling and hand nut) up. See Figure 5-18.
3. Connect a 1/16 inch (1.59 mm) diameter Type J thermocouple to the thermocouple jack on the left side. Insert the thermocouple (connected to digital thermometer) into the hole in top of the fluid loss reservoir. See Figure 5-17.



**Figure 5-16** Heating Jacket Thermocouple plugs on left side of the instrument



**Figure 5-17** Cell Thermocouple partially inserted in reservoir





**Figure 5-18 Reservoir in heating jacket for pre-heating**



---

The heating jacket and fluid loss reservoir do not have to be vertical for proper heating to occur.

---



---

Never operate the heating jacket without a thermocouple. Not using a thermocouple will result in loss of temperature feedback and overheating. The overheating could become severe enough to cause melting. Keep the front panel heater control switch on the OFF position until ready to pre-heat the jacket or conduct a fluid loss test.

---







4. Turn on the Master Power Switch, located on left side of the instrument. See Figure 5-16.



---

The maximum temperature is 212°F (100°C). Any test run above that temperature will make the test readings inaccurate.

---

5. Adjust the temperature controller to the desired temperature.
  - a. From the home display, press page button  until you reach **ProG LiSt**.
  - b. Press scroll button .
  - c. Use the arrow keys to select the number of the program to be changed.
  - d. Press .
  - e. For each program setting, use  or  to change the displayed value. After releasing the button, the display will blink to show the controller has accepted the new value.
  - f. Continue to press  until you have reviewed or changed the desired program values and return to the **ProG LiSt** display.
  - g. Press the Run/Hold button.
6. Turn on the heater using the heater control switch
7. Observe the temperature controller for a flashing OP1 indicator and an increasing temperature. The temperature controller will continually turn power on and off to the heating jacket until the thermocouple reaches the desired temperature. Heating the empty fluid loss reservoir to the desired temperature will take approximately 20 to 30 minutes.

### 5.3 Setting the first time alarm on the timer

- Press the **Down** key to select the preset time mode. The letter **P** will appear on the left.



- Press the **Next** key to scroll through Hours:min:sec
- When the digit is blinking press the **Down** key to select the desired value.



- Press the **Next** key to continue scrolling through the digits, change values as needed with the **Down** key.
- Press the **Next** key until no digits are blinking.
- Press the **Down** key to switch from Preset mode to Operation mode. The letter **H** will appear on the left.



- Press the **Reset** Key, to reset the time value.



## 5.4 Conditioning the Slurry

Follow your standard operating procedures and refer to API RP 10B-2.



The fluid loss reservoir assembly constitutes a pressure vessel. The safety precautions listed in Section 2.1 should be followed to assure safe operation.



The reservoir material should be compatible with the test sample.



Reservoir cylinders and caps that have cracking, severe pitting, or damaged threads must not be used.



Wear thermally protective gloves when removing or inserting the heated fluid loss reservoir. The reservoir and heating jacket will be hot.

## 5.5 Loading the Fluid Loss Reservoir

1. After the slurry has been preconditioned, and the fluid loss reservoir and heating jacket have reached the desired temperature, turn off the heater.
2. Remove the thermocouple from the reservoir assembly.
3. Remove the empty heated reservoir from the heating jacket. Place it on the reservoir stand with the top (loose) end cap up.
4. Fully remove the non-filtered (top) end cap.
5. Pour the prepared slurry into the cylinder to 3/4 inch (1.9 cm) below the O-ring ledge.

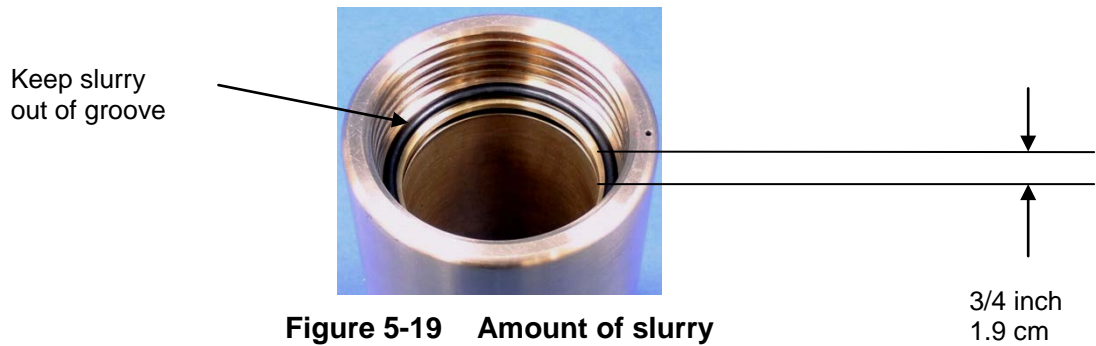

**Figure 5-19 Amount of slurry**



DO NOT take more than two minutes to transfer the slurry and begin the test!

6. Screw the top cap back and tighten it firmly with wrenches.



**Figure 5-20 Tighten top cap with wrenches**



DO NOT turn the cylinder over after the slurry has been poured into it! Hold it upright.

7. Insert the slurry cylinder into the heating jacket, and fully insert the thermocouple.
8. Turn on the heater.

9. Completely tighten the hand nut to the bottom of the valve head assembly. When fully tightened, the reservoir will lift out of the heating jacket by about 1/4 inch (0.6 cm).

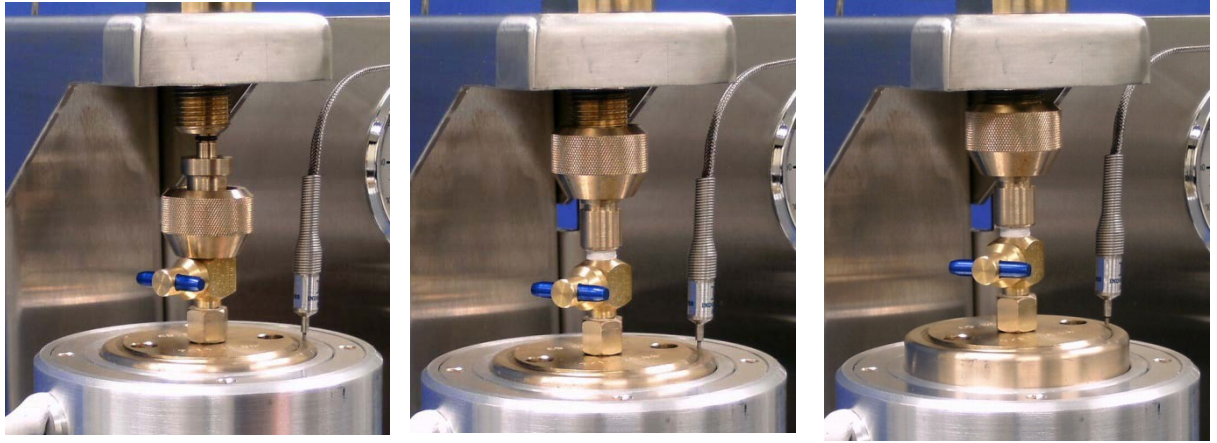

**Figure 5-21 Hand nut tightened to valve head assembly**

10. Place the fluid loss measuring cylinder under the bottom valve.

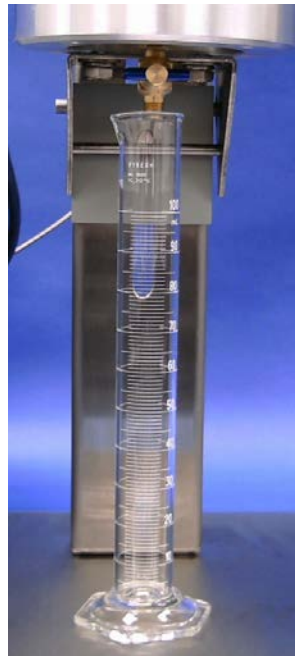

**Figure 5-22 Graduated cylinder below bottom valve**

11. Open the top cylinder valve by turning the valve handle until it is in line with the inlet.

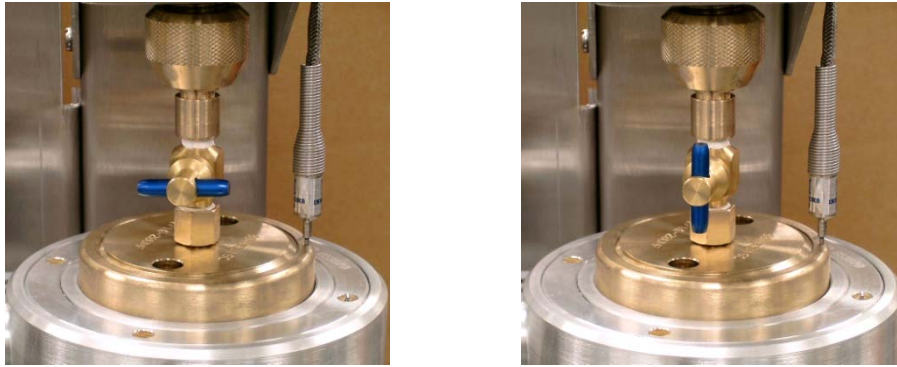

**Figure 5-23 Top reservoir valve (closed on left, open on right)**

**5.6 Setting the Test Pressure**

1. Close the pressure vent valve and inlet valve on the pressure manifold. See Figure 5-3.
2. Turn the pressure regulator knob fully counter-clockwise.
3. Connect the pressure source (nitrogen, compressed air, or other safe gas) to the instrument’s gas supply connection.
4. Slowly open the valve at the pressure source, and observe the gauge to indicate the pressure in the source.
5. Slowly rotate the pressure regulator knob clockwise to increase the pressure to be applied to the test sample. API RP10B-2 recommends  $1000 \pm 50$  psi ( $7000 \pm 300$  kPa) be maintained during the test.



**Figure 5-24 Pressure Gauges and Regulator**

6. Open the pressure inlet valve on the top of the pressure manifold. When open, the valve handle should be in line with the valve inlet and outlet.

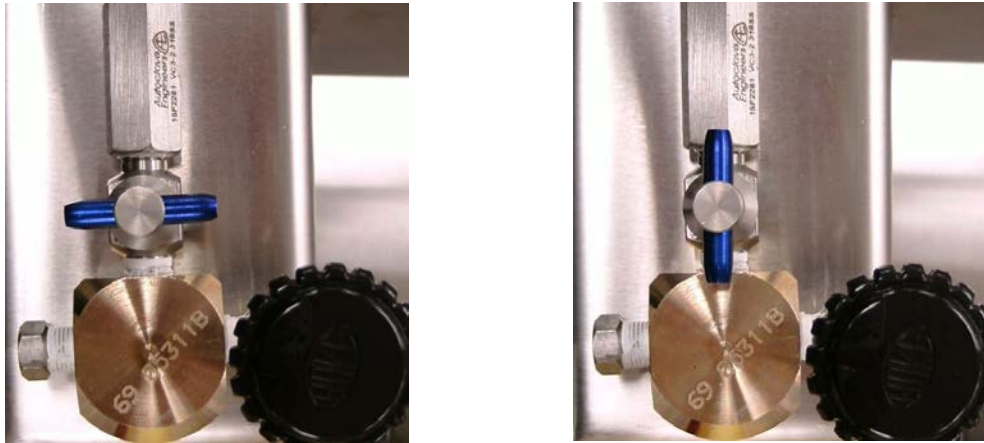

**Figure 5-25 Pressure Manifold Inlet Valve (closed on left, open on right)**

### **5.7 Starting the Fluid Loss Test**

1. To pressurize the slurry, open the top reservoir inlet and bottom reservoir outlet valves by turning them 90 degrees. When open, the valve handle should be in line with the valve inlet and outlet.

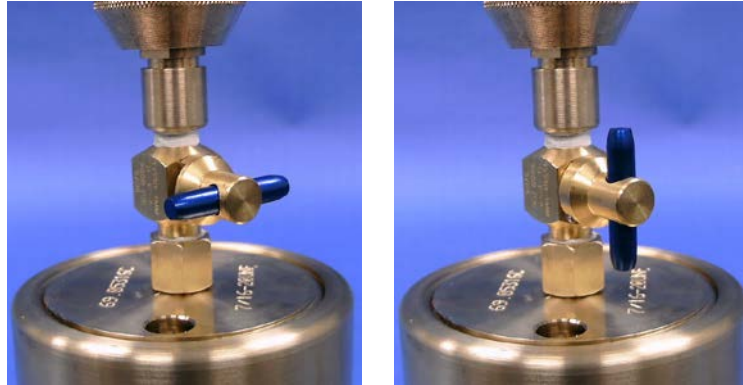

**Figure 5-26 Top reservoir inlet valve (closed on left, open on right)**





**Figure 5-27 Bottom reservoir outlet valve (closed on left, open on right)**

2. Start the timer or stopwatch.
3. Record the filtrate collected in the graduated cylinder at the required time intervals according to the test requirements.
4. Adjust the timer as necessary, following the steps in Section 5.3.

### 5.8 Stopping the Fluid Loss Test



Wear a face shield and thermally protective gloves when closing valves, releasing pressure, and removing the heated fluid loss reservoir. The reservoir and heating jacket will be hot.



Keep all body parts away from the pressure release valve outlet when releasing pressure.

1. If additional tests will not be immediately started, turn the off the heater.
2. Close the bottom (outlet) reservoir valve by turning it 90 degrees. See Figure 5-27.
3. Close the pressure manifold inlet valve by turning it 90 degrees. See Figure 5-26.

4. If additional tests will not be immediately started, turn off the pressure source at the supply (tank, manifold, or wall).
5. If additional tests will not be immediately started, release the pressure regulator by turning it fully counterclockwise.
6. SLOWLY open the pressure release needle valve by turning it counterclockwise. This releases pressure in the fluid loss reservoir.
7. When all pressure has been released, loosen the hand nut and allow the heating jacket to tip outward to permit the reservoir to be removed.
8. The reservoir may be left in the heating jacket or it may be removed to another location, such as the reservoir stand, for air cooling.



Be extremely careful if removing the hot reservoir from the heating jacket. It can cause severe burns if accidentally touched.



Immersing the hot fluid loss reservoir in water to cool it is very dangerous and creates steam which can cause severe burns. This practice is not recommended.



DO NOT turn the reservoir over. It is full of slurry. Hold it upright.

9. After the reservoir is cool, open the valves in the top and bottom caps.
10. Disassemble the reservoir in the reverse order of assembly.
11. Clean all parts with water.
12. Force water through the valves in both caps.
13. Clean and inspect all parts for damage.
  - a. Hold the screen up to a light. Shadowed areas indicate plugging and need to be cleaned.

- b. Screens with scratches or holes must be replaced.
- c. O-rings that are cut or deformed must be replaced. Do not store O-rings between tests with grease applied to them. Stopcock grease should only be applied to the O-rings immediately before use.

### **5.9 Storing the Reservoir**

The slurry reservoir may be stored either assembled or disassembled.



Do not store the slurry reservoir in the heating jacket. The two dissimilar metals will cause a reaction and may bond together.

---

## 6 Test Analysis

### 6.1 References

API Recommended Practice for Testing Well Cements, API RP 10B-2.

### 6.2 Results

Test results will vary.

According to API RP 10B-2, fluid loss tests that run the full 30 minutes typically show 5% variability. However, potential error increases for tests that run less than 30 minutes. For test times less than 5 minutes, the variability may be more than 30%.

A fluid loss test performed in a single laboratory on a cement slurry with a fluid-loss control additive and water, and having an average fluid-loss value of approximately 350 ml/30 min, typically has a standard deviation of approximately 84 ml/30 min and  $2V_c$  (variability coefficient) of approximately 47%.

### 6.3 Variations

Variations in the procedures, the involvement of numerous people and laboratories, and the presence of multiple additives in the slurry can considerably increase test result variations. When one person performs the test on one instrument or when the fluid-loss value is low, the variation usually decreases.

To keep testing variations to a minimum, do the following:

- Keep the testing equipment in good condition, clean, and accurately calibrated.
- Perform the tests according to the prescribed procedures.
- Keep the test conditions within the acceptable limits (API or customer-specified).
- Minimize oil contamination in slurries that have been preconditioned in an HPHT Consistometer.

## 6.4 Filtrate Volume

The volume of liquid filtrate collected is measured in milliliters (mL) to the nearest 1.0 ml. The volume is recorded at 30 seconds, and 1, 5, 10, 15, 20 and 30 minutes after the test begins.

Alternatively, the filtrate may be continuously weighed and recorded. When weighed, the filtrate specific gravity must be measured and reported at 80°F (26.7°C), and the recorded filtrate volumes corrected for specific gravity.

When a condenser is used, the filtrate volume in the condenser should be recorded.

## 6.5 Calculations

- For tests that run the entire 30 minutes without blowing dry, calculate API Fluid Loss as follows:

$$API \text{ Fluid Loss} = 2 Q_{30}$$

where  $Q_{30}$  is the volume of filtrate collected at 30 minutes in ml.

- If nitrogen blows through in less than 30 minutes, record the filtrate volume collected and time at which the blow-through occurs. Calculate the API Fluid Loss by the formula:

$$Calculated \text{ API Fluid Loss} = 2 Q_t \frac{5.477}{\sqrt{t}}$$

where  $Q_t$  is the volume (ml) of filtrate collected at the time  $t$  (min) of the blowout.

## 6.6 Reporting

When reporting the fluid loss of cement slurries, those tests where the fluid loss was measured for a full 30 minutes will be reported as “API Fluid Loss.” Those tests in which the fluid “blew out” in less than 30 minutes will be reported as “Calculated API Fluid Loss.”

## 7 Troubleshooting and Maintenance

Standard laboratory procedures apply for cleaning the Fluid Loss Test Instrument.

- After each test, thoroughly clean the caps, reservoir body and valves of all sample and other contaminants; pay particular attention to O-rings and O-ring grooves. Thoroughly dry these parts for the next test.
- Wash and dry the filter screens.
- Wipe spilled sample and other debris from the heating jacket and stand. Some sample materials may damage the finish of these parts.

### 7.1 Fluid loss reservoir maintenance

#### 7.1.1 O-rings

Inspect all O-rings as they are being cleaned for cuts or nicks and for distortion. Check for hardening or brittleness. Replace any damaged O-rings. Immediately before they are installed, lubricate the O-rings with laboratory stopcock grease. Since the O-rings may come into contact with the sample, care should be taken that the lubricant is compatible with the sample.

#### 7.1.2 Valves

When properly tightened, the tapered pipe threads make a metal to metal, pressure tight, seal between the valve and the cap. Leaks can occur if the threads of either the valve or cap are damaged.

Valves should be inspected for possible plugging of the passages by dried sample. A small drill or wire can be used to insure the main passage bore is clear.

#### 7.1.3 Corrosion

Slurry samples under the temperature and pressure conditions used in this type testing can cause corrosion of the reservoir and caps. Periodically inspect the inside of the reservoir for corrosion. Light corrosion may be removed by using 320 grit or finer sand paper, wet or dry. Deeper corrosion pitting may be removed by sand blasting the area of the corrosion. More severe corrosion will require re-machining or re-surfacing the inside of the reservoir. If machining to 0.020 inch (0.5 mm) oversize does not remove all corrosion, it is recommended that the reservoir be replaced. If corrosion cracks are evident, the reservoir should be replaced.



---

Corrosion, pitting, and cracking can cause rupture of cells.

---

## 7.2 Pressurization systems

To safely operate pressurized equipment, the pressurizing system must be properly maintained. Specific procedures for the safe use of pressure regulators are listed below.

1. Never subject a regulator to an inlet pressure greater than its rated inlet pressure, as shown on the regulator body.
2. Never use the regulator for gases other than those for which it is intended.
3. All connections to the regulator must be clean. Remove oil, grease, or other contaminants from external surfaces of the regulator and metal connecting parts.
4. Before attaching high pressure tubing to the pressure source (tank, manifold, or wall-mounted valve), remove any dirt or foreign matter from the mating surfaces by wiping it with a clean, lint free, cloth.
5. Never pressurize a regulator that has loose or damaged parts or is in questionable condition. Never loosen or attempt to tighten a connection or a part until the gas pressure has been relieved. Under pressure, gas can dangerously propel a loose part.
6. Check regulator and all connections for leaks after installation, periodically thereafter, and after any service in which parts or connections were disconnected and reconnected. Use a soap solution around fittings to find small leaks. Bubbles will indicate a leak.



---

The valve on the pressure source may be opened momentarily to blow the outlet clean. Make sure no one is near the opening before it is opened.

---

### 7.3 Pressurization system troubleshooting

The primary causes of pressurization system problems are caused by leaking fittings, dirt in the regulators, or faulty seats in the regulator. Rarely does a diaphragm rupture. If a regulator will not hold pressure, then do the following:

Check for leakage around fittings. Pressure the system and look for escaping gas in the form of bubbles. This can be done by applying soap suds to the possible leak areas. Repair fitting leaks by disassembling, cleaning the threads, and then applying a good thread sealant or Teflon® tape thread sealant before re-installing fitting.

Check for a faulty regulator. A faulty seat is often evidenced by leakage through the regulator to the downstream side as opposed to external leakage. Check for bubbles coming out of the regulator when the regulator knob is turned fully counterclockwise.

### 7.4 Faulty pressure regulator

One or more of the following conditions will be evidenced when a regulator is faulty:

- Gas leaking at the regulator outlet when the adjusting knob is turned completely counter-clockwise and all pressure is released.
- With no flow through the system (downstream valves closed and pressure showing on the reservoir gauge), the reservoir gauge pressure is steadily increasing.
- Gas leakage from the regulator case at any point.
- Excessive drop in the reservoir pressure with the regulator flow open.

### 7.5 Pressure regulator repair

If it is determined a regulator is faulty, it must be removed from service and professionally repaired or replaced.

### 7.6 Temperature controller troubleshooting

The electronic temperature controller senses the temperature through a Type J thermocouple placed in the heating jacket. It controls the temperature by rapidly turning on and off the power applied to the heating jacket heaters. The relationship between the ON time and the OFF time per cycle determines the temperature. A manual switch is located on the front panel to enable and disable the heating jacket independent of the temperature controller. The main power switch is located on the rear of the temperature controller. Malfunctioning of any of these sub-systems or components can cause improper heating of the slurry sample. Refer to Table 7-1 for assistance in troubleshooting problems with the temperature controller.



**Table 7-1 Temperature controller problems**

<b>Problem or Symptom</b>	<b>Possible Cause</b>	<b>Corrective Action</b>
The controller does not power up.	The power source is disconnected or turned off.	Check the power source.
	The main power switch has malfunctioned or failed.	Check or replace the main power switch.
	The power wiring is faulty.	Check/repair the power wiring. Refer to the wiring diagram.
The system does not heat up, but the heater indicator in the temperature controller is on.	The heater control switch is turned off.	Turn the heater control switch on.
	The heating jacket is not plugged into the temperature controller power outlet.	Plug the heating jacket into the temperature controller power outlet.
	The heater fuse has blown	Check/replace if necessary
	Solid state heater relay has failed.	Check/replace, if necessary.
	The heating jacket wiring is faulty.	Check/repair the heating jacket wiring.
The system does not heat up, and the heater indicator in the temperature controller is off.	The heater fuse has blown.	Check/replace the heater fuse.
	The heater control electronics malfunctioned or failed.	Check the heater solid-state relay, and the heater circuit wiring. Refer to the wiring diagram.
The temperature reading is unreasonably high (over 500°F).	Possible open circuit in thermocouple or thermocouple cables.	Look for and repair the broken wire or loose connection at the thermocouple connector.
The temperature reading is about room temperature, and the heating jacket is hot.	Possible short circuit in thermocouple or thermocouple cable.	Look for and repair the short in the thermocouple connector.

**7.7 Heater element troubleshooting**

The aluminum heating jacket contains four heater elements for both 110V and 220V operation. The heater elements may be tested for proper operation by measuring across the heating jacket plug terminals with an ohmmeter. See Table 7-2 below.



Always disconnect the power cable and allow the heating jacket to cool before attempting any repair.

**Table 7-2 Heater element measurements**

<b>Model</b>	<b>Ohmmeter Measurement</b>	<b>Fault</b>
110V	9 Ohms ± 1 Ohm	None, all elements are good
	18 Ohms ± 1 Ohm	One element bad, any combination
	27 Ohms ± 1 Ohm	Two elements bad, any combination
	36 Ohms ± 1 Ohm	Three elements bad, any combination
	Infinity (open)	Four elements bad, any combination
220V	36 Ohms ± 1 Ohm	None, all elements are good
	72 Ohms ± 1 Ohm	1 or 2 heater elements on a single leg are bad
	Infinity (open)	1 or 2 heater elements on the first leg are bad, and 1 or 2 heater elements on the second leg are bad.

**7.8 Heating jacket removal**

1. Unplug the heating jacket from the temperature controller.
2. Use a wrench to loosen the two 3/8-24 hex head cap screws holding the heating jacket to the slide block assembly. These are located on the bottom side of the heating jacket.
3. Fully remove the two 3/8-24 hex head cap screws to completely release the heating jacket.

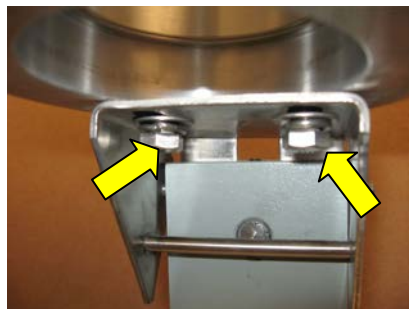

**Figure 7-1 Heating jacket bolts**

**7.9 Heating element replacement**

1. Remove four flat head screws and pry off the ring to gain access to the four heater elements.

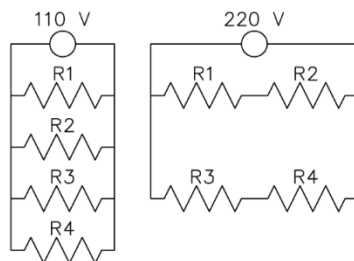

**Figure 7-2 Heating element cover screws**



**Figure 7-3 Heating elements and wiring exposed**

2. Before disconnecting any wires, determine if the heating jacket is wired for 110V or 220V. See Figure 7-4.



**Figure 7-4 Heating elements wiring diagrams**

3. Disconnect and test each heating element with an ohmmeter for an open or short circuit. The measured resistance of functioning heating elements is  $36 \pm 1$  ohms.
4. It may be possible to drive out the defective heating element with a slim punch inserted through four bottom holes.

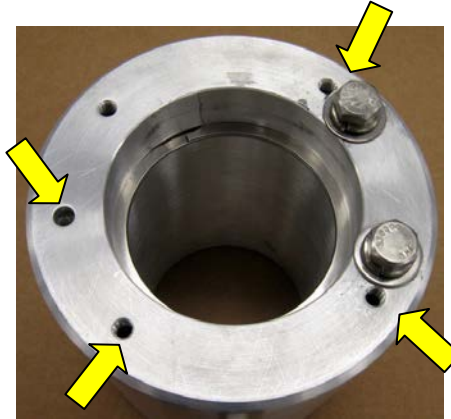

**Figure 7-5 Holes to drive out heating elements**

5. If driving them out fails, it may be necessary to drill them out from the top. Use a drill no larger than 5/16 (0.312) inch 7.9 mm).
6. After the defective elements have been replaced, reconnect them according to the correct wiring diagram in Figure 7-4.
7. Re-assemble the heating jacket, being careful not to damage the wire insulation when replacing the heating element cover. Do not over tighten the retaining screws. See Figure 7-2.

### 7.10 Heating jacket re-mount

1. Attach the heating jacket to the pivot slide block assembly. Use two 3/8-24 hex head cap screws inserted through the slide block and into the heating jacket bottom. See Figure 7-1.
2. Place an empty, unheated, slurry reservoir and top cap with valve, into the heating jacket.
3. Loosen the slide block assembly tee screw (located on the back side of the frame).
4. Adjust the slide block, heating jacket, and slurry reservoir to where the hand nut just clears the bottom of the valve head assembly. See Figure 7-6.
5. Tighten the slide block tee screw firmly to hold the assembly in place.

6. Tighten the heating jacket screws to hold the assembly in place.



---

The heating jacket power cord should be on the left side.

---



**Figure 7-6 Correct height of heating jacket**

## 8 Accessories

The accessories listed in Table 8-1 are not furnished with the fluid loss test instrument, but may be needed to perform some tests.

**Table 8-1 Accessories**

<b>Part No.</b>	<b>Description</b>
206897	STOPWATCH, ANALOG
206898	STOPWATCH, DIGITAL, ELECTRONIC

**9 Parts List**

**Table 9-1 Cement Fluid Loss Tester, Single Cell, 115V, P/N 101502980, Revision M**

<b>Part No.</b>	<b>Quantity</b>	<b>Description</b>
101775743	1	BASIC UNIT, CEMENT FLUID LOSS TESTER, SINGLE CELL
100020402	1	JACKET ASSEMBLY, HEATING, 120V
100013087	1	RECEPTACLE, FLANGED, 15 AMP, 125 VAC, /DC, TWIST LOCK
203522	1	CABLE POWER 115V 14 AWG
100031033	1	RESISTOR, 30000 OHM, 1/2 WATT

**Table 9-2 Cement Fluid Loss Tester, Single Cell, 230V, P/N 101533370, Revision M**

<b>Part No.</b>	<b>Quantity</b>	<b>Description</b>
100020424	1	JACKET ASSY,,HEATING, 240V
100031172	1	RECEPTACLE, FLANGED, 15A 250 VAC/DC, TWIST LOCK
100026189	6	CORD, PORTABLE, 3 X 1.5 SQ MM, VDE APPROVED
100031126	1	PLUG, GROUNDING, 250 V, 15 AMP
100027804	1	RESISTOR, 100000 OHM, 1 WATT
101775743	1	BASIC UNIT, CEMENT FLUID LOSS TESTER, SINGLE CELL

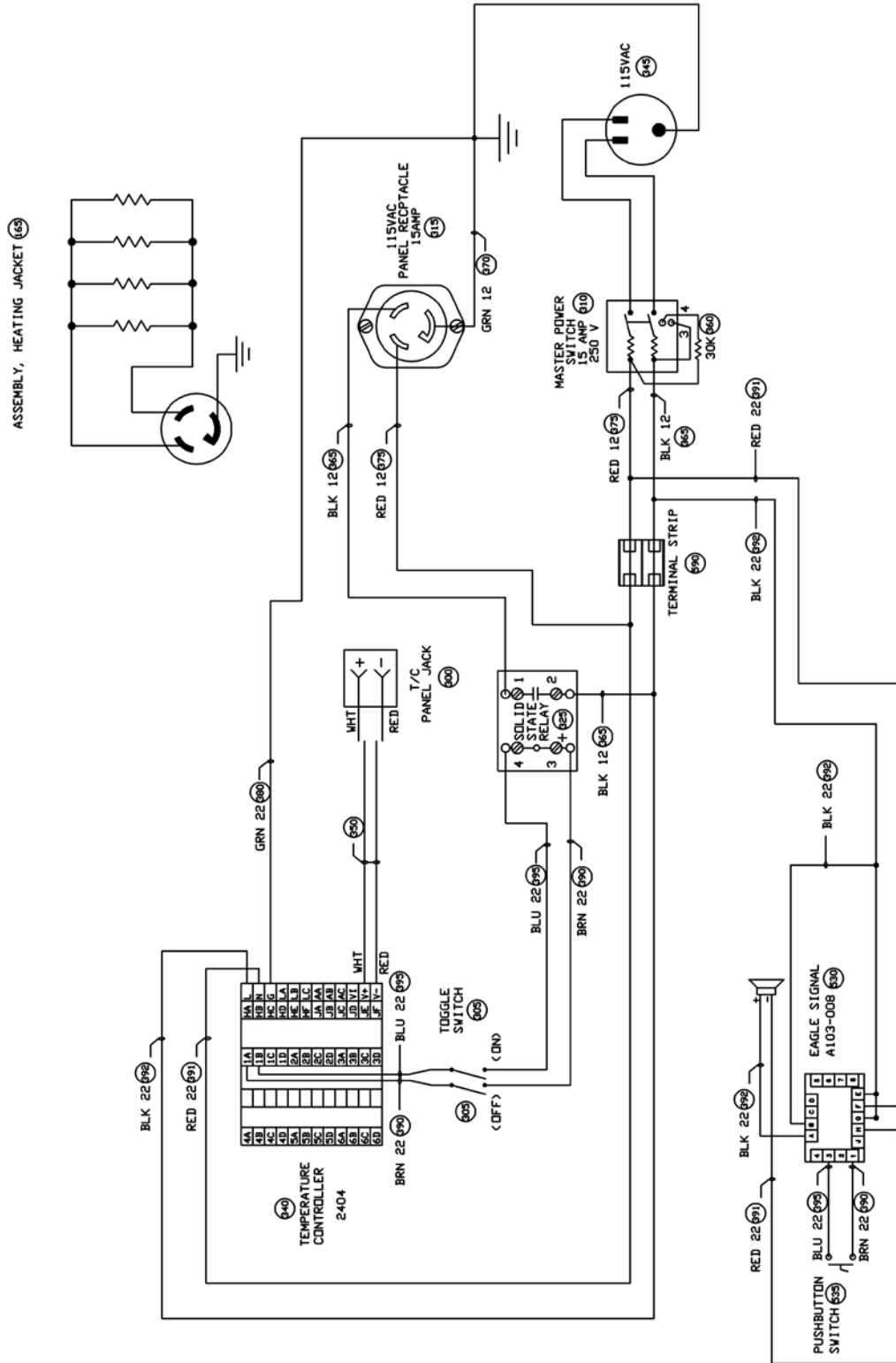

Figure 9-1 Wiring Diagram, Single Cell Cement Fluid Loss Tester, 115 VAC



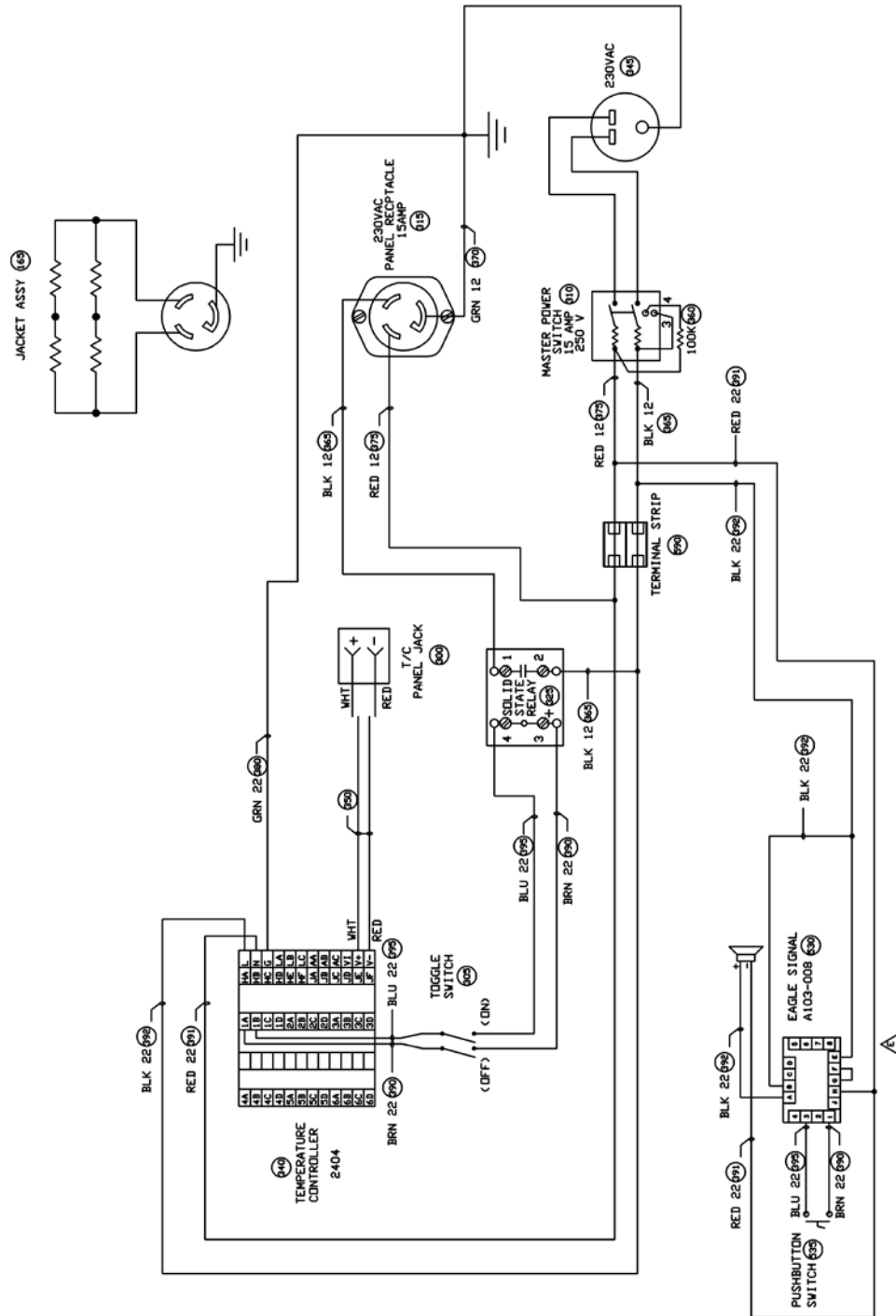

Figure 9-2 Wiring Diagram, Single Cell Cement Fluid Loss Tester, 230 VAC

Table 9-3 Manifold Assembly, High Pressure, P/N 100020406, Revision D

Item No.	Part No.	Quantity	Description
0001	100026516	1	NUT, HEX, 7/8-14 UNF
0002	100029879	1	WASHER, FLAT, 7/8 NOM, STEEL, 0.93 IDX 2.25 OD X 0.165 THK
0003	100020408	1	TEE, 1/8 NPT, HIGH PRESSURE MANIFOLD, CORE FILTER PRESS
0004	100000593	1	VALVE, PLUG, 1/8 MNPT, BRASS, 3000 PSI, 250 F, BUNA N SEALS
0005	100016570	1	PLUG, PIPE, 1/8, STAINLESS STEEL, HEX SOC HEAD
0009	100032964	1	VALVE, NEEDLE, 1/8 NPTM CONNECTOR, BRASS BODY

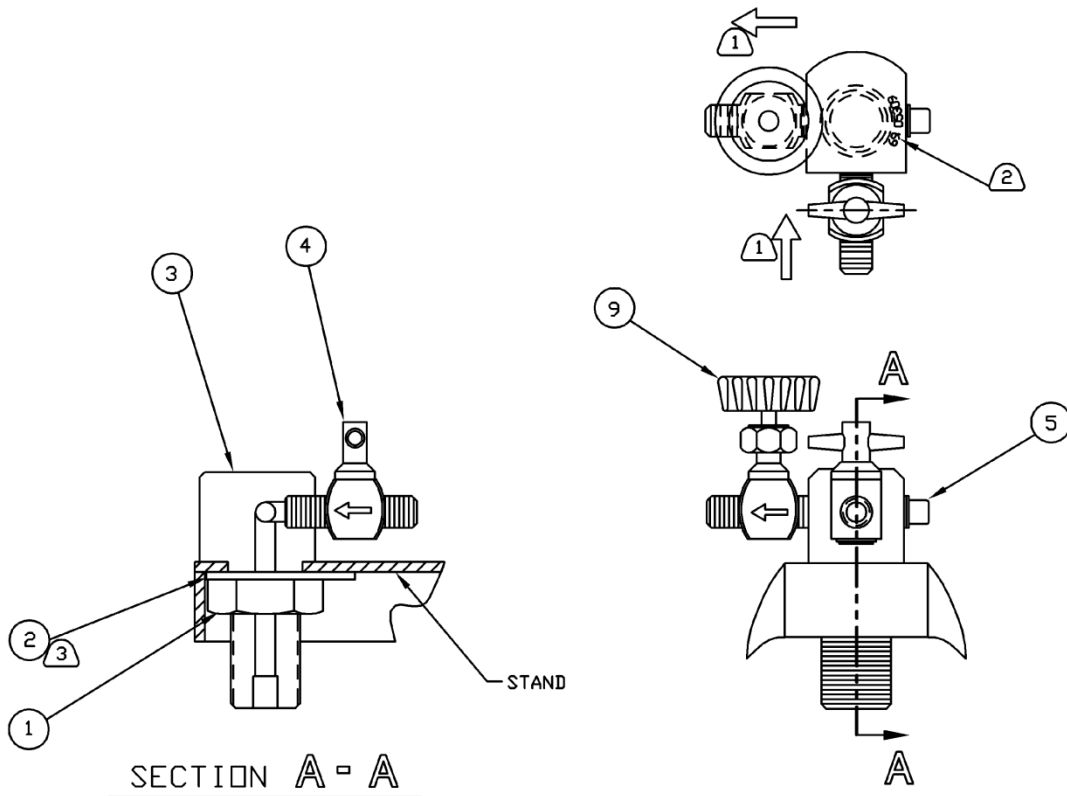
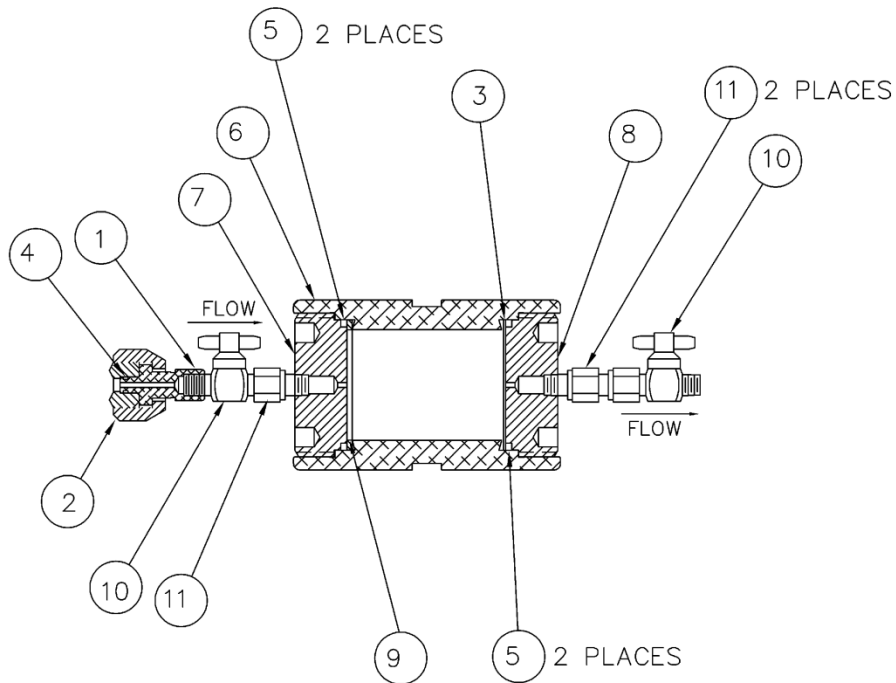

Figure 9-3 Manifold Assembly

**Table 9-4 Cell Assembly, Fluid Loss, Short Cell, P/N 101776831, Revision B**

Item No.	Part No.	Quantity	Description
0001	100020409	1	COUPLING, HIGH PRESSURE MANIFOLD, FLUID LOSS CORE FILTER PRESS
0002	100020410	1	NUT, HP MANIFOLD, CORE FILTER PRESS
0003	100002402	1	SCREEN, 325 X 60 MESH, FLUID LOSS, FILTER PRESS
0004	100026664	1	O-RING, 70 DURO, 5/16 X 3/16 X 1/16 568-008
0005	100001882	4	O-RING, 70 DURO, 2 1/2 X 2 1/4 X 1/8 568-228
0006	100020411	1	RESERVOIR, 5 1/8 FILTER PRESS
0007	100020425	1	CAP, FILTER FLUID LOSS
0008	100020426	1	BASE, CAP, FILTER FLUID LOSS
0009	100001364	1	RING, BACK-UP, FILTER PRESS ASSEMBLY
0010	100000593	2	VALVE, PLUG, 1/8 MNPT, BRASS, 3000 PSI, 250 F, BUNA N SEALS
0011	100033660	3	ADAPTER, HOSE, 2AP, STRAIGHT, 1/8 MALE PIPE THREAD X 1/8 IFPT, BRASS, HOKE



**Figure 9-4 Cell Assembly**

**Table 9-5 Basic Unit, 115 VAC and 230 VAC, P/N 101775743, Revision F**

<b>Item No.</b>	<b>Part No.</b>	<b>Quantity</b>	<b>Description</b>
0002	100029878	2	WASHER, FLAT, 5/8 NOM, STEEL, 0.69 ID X 1.75 OD X 0.134 THK
0003	205372	1	ROD, STEEL
0004	100028807	1	SCREW, SET, 1/4-20 NC X 3/8, CUP PORT, HEX SOCKET
0007	100020399	1	BLOCK, SLIDE
0008	101502979	1	FRAME
0009	100020400	1	BRACKET, HP MANIFOLD CORE FILTER PRESS
0010	100032968	1	COUPLING, 1/8 NPT FEMALE, 1/8 ERMETO W125
0012	100029698	6	TUBING, STAINLESS STEEL, 1/8 OD X .062 ID, .032 WALL THICKNESS
0013	100032365	1	GAUGE, PRESSURE, DUAL SCALE, 4 INCH, 0-2000 PSI/0-13800 KPA, 1.5%, SC BOURDON TUBE/316 SS
0014	100032362	1	GAUGE, PRESSURE, DUAL SCALE, 4 INCH, 0-5000 PSI/0-34, 500 KPA, 1.5%, SC BOURDON TUBE/COPPER ALLOY
0015	100032967	2	COUPLING, 1/4 NPTF, 1/8 ERMETO W125
0016	100032969	1	NIPPLE, INLET, 1/4 NPT-15-4
0017	100032970	1	NUT, INLET, ARGON NITROGEN
0018	100032366	1	REGULATOR, PRESSURE, 0-2500 PSI OUTLET
0019	100032370	4	FITTING, TUBE, B-200-2-4, ELBOW, 90 DEG, BRASS, 1/8 TUBE X 1/4 MALE PIPE THREAD
0020	100020401	1	BASE, PLATE
0021	100007781	2	SCREW, HEX SOCKET, 1/4-20 NC X 3/8
0022	100028451	4	SCREW, HEX CAP, 3/8-16 NC X 1/2
0023	100029874	8	WASHER, FLAT, 3/8 NOM, STEEL, 0.44 ID X 1 OD X 0.104 THK
0024	101576155	1	BRACKET PANEL FOR TESCOM REGULATOR
0027	100020406	1	MANIFOLD ASSEMBLY, HIGH PRESSURE, CORE FILTER PRESS
0100	101776831	1	CELL ASSEMBLY
0115	101733741	1	THERMOCOUPLE, TYPE J, .062 DIA x 3.88 LG, 36 IN. LEADS
0130	100028324	2	SCREW, HEX CAP, 3/8-24 NF X 3/4, PL, SPEC 70.43917
0170	100020419	1	WRENCH, RESERVOIR
0180	100030677	1	WRENCH, SPANNER, FACE, ADJUSTABLE, 3 MAX SPAN BETWEEN CENTERS, 1/4 DIAPINS, 8.25 LG
0300	100072391	1	PANEL MOUNT, SINGLE CIRCUIT, THERMOCOUPLE
0305	100029446	1	SWITCH, TOGGLE
0310	100034198	1	SWITCH, CIRCUIT BREAKER
0320	100072627	1	HEAT SINK
0322	207633	8	NUT 10-32 HEX REGULAR SS
0324	101443558	4	FLANGE BUTTON SOCKET HEAD CAP SCREW 10-32 1/2 LENGTH
0325	100013136	1	RELAY, SOLID STATE, 240 VAC, 25 AMP, 3-32 VDC CONTROL
0331	207617	4	6-32 X 3/4 THMS SS

<b>Item No.</b>	<b>Part No.</b>	<b>Quantity</b>	<b>Description</b>
0332	207632	4	NUT 6-32 HEX REGULAR SS
0340	101881426	1	TEMP CONTROLLER, EURO THERM 2404
0350	208485	24	WIRE THERMOCOUPLE DUPLEX TYPE
0365	206246	2.5	WIRE 12 AWG PVC STRANDED 600V BLACK
0370	206248	2	WIRE 12 AWG PVC STRANDED 600V GREEN
0375	206247	2.5	WIRE 12 AWG PVC STRANDED 600V RED
0380	206229	2	WIRE 22 AWG PVC STRANDED GREEN
0390	208516	3.25	WIRE 22 AWG PVC STRANDED BROWN
0391	208548	3	WIRE 22 AWG TEFLON STRANDED RED
0392	208547	3	WIRE 22AWG TEFLON STRANDED BLACK
0395	206242	3.25	WIRE 22 AWG TEFLON STRANDED BLUE
0400	207336	4	8-32 X 3/8 BHMS SS
0420	100002481	1	CONNECTOR, 0.27 TO 0.48 DIA CORD
0500	203988	1	CONNECTOR BULKHEAD 1/8TUBE X 1/8FNPT
0502	101565543	1	UNION, BULKHEAD, 1/8 IN. TUBE, 316SS
0505	205406	1	HOSE 5750 PSI 5 LONG 1/8in. MNPT ENDS
0510	204038	1	COUPLING REDUCING 1/4FNPT X 1/8FNPT
0520	208982	1	ALARM, HEAT
0530	101583950	1	PRESET TIMER
0535	101482680	1	SWITCH, PUSHBUTTON, ON/OFF
0540	101553623	1	OUTPUT RELAY, EAGLE SIGNAL
0550	100020407	1	BOLT, T-HANDLE
0570	207921	2	8-32 X 3/4 BHMS SS
0580	207631	4	NUT 8-32 HEX REGULAR SS
0590	205147	1	TERMINAL STRIP CINCH
0600	101585348	1	MOUNTING BRACKET, TERMINAL STRIP
0650	205779	4	FEET RUBBER 3/4IN.
0660	203411	4	10-32 X 1/2 FHMS SS
0700	100033342	1	SCREEN, 600 MESH
0750	100029508	2	TERMINAL, CRIMP, 12-10 GA, #10 STUD, RING TYPE, INSULATION CRIMP
0760	100032006	1	TERMINAL, FEMALE, SLIP ON, FULLY INSULATED FOR 18-22 GA WIRE
0770	100032234	6	TERMINAL, CRIMP, RING, 12-10 AWG, YELLOW, #6 STUD, TYPE 3
0780	349301	4	TERMINAL FEMALE Q.C., 25X.032 12-10GA NYLON FULLY INSULATED
0790	208454	21	TERMINAL FORK 6 22-16 AWG
0800	207895	4	WASHER FLAT 8
0810	207947	4	WASHER SPLIT 8 SS
0820	207871	4	WASHER FLAT 10 SS
0830	208704	4	WASHER SPLIT 10 SS
0840	208658	2	WASHER FLAT 6 SS
0850	101201164	2	WASHER SPLIT LOCK
0860	100123899	2	SCREW, CAP, SOCKET HEAD, 1/4-20 NC X 3/4, SS

## **10 Warranty and Returns**

### **10.1 Warranty**

Fann Instrument Company warrants only title to the equipment, products and materials supplied and that the same are free from defects in workmanship and materials for one year from date of delivery. **THERE ARE NO WARRANTIES, EXPRESS OR IMPLIED OF MERCHANTABILITY, FITNESS OR OTHERWISE BEYOND THOSE STATED IN THE IMMEDIATELY PRECEDING SENTENCE.** Fann's sole liability and Customer's exclusive remedy in any cause of action (whether in contract, tort, breach of warranty or otherwise) arising out of the sale, lease or use of any equipment, products or materials is expressly limited to the replacement of such on their return to Fann or, at Fann's option, to the allowance to Customer of credit for the cost of such items. In no event shall Fann be liable for special, incidental, indirect, consequential or punitive damages. Notwithstanding any specification or description in its catalogs, literature or brochures of materials used in the manufacture of its products, Fann reserves the right to substitute other materials without notice. Fann does not warrant in any way equipment, products, and material not manufactured by Fann, and such will be sold only with the warranties, if any, that are given by the manufacturer thereof. Fann will only pass through to Customer the warranty granted to it by the manufacturer of such items.

### **10.2 Returns**

For your protection, items being returned must be carefully packed to prevent damage in shipment and insured against possible damage or loss. Fann will not be responsible for damage resulting from careless or insufficient packing.

Before returning items for any reason, authorization must be obtained from Fann Instrument Company. When applying for authorization, please include information regarding the reason the items are to be returned.

Our correspondence address:

**Fann Instrument Company**  
P.O. Box 4350  
Houston, Texas USA 77210

Telephone: 281-871-4482  
Toll Free: 800-347-0450  
FAX: 281-871-4446

Email [fannmail@fann.com](mailto:fannmail@fann.com)

Our shipping address:

**Fann Instrument Company**  
14851 Milner Road, Gate 5  
Houston, Texas USA 77032