

# iX77™ Rheometer Instruction Manual



**Manual No. 101625591, Revision G**

**Instrument No. 101543382**

**iX77<sup>®</sup> Rheometer User Manual**

©2014 Fann Instrument Company

Houston, Texas, USA

All rights reserved. No part of this work covered by the copyright hereon may be reproduced or copied in any form or by any means (graphic, electronic, or mechanical) without first receiving the written permission of Fann Instrument Company, Houston, Texas, USA.

Printed in USA.

The information contained in this document includes concepts, methods, and apparatus which may be covered by U.S. Patents FANN<sup>®</sup> reserves the right to make improvements in design, construction, and appearance of our products without prior notice.

FANN<sup>®</sup> and the FANN logo are registered trademarks of Fann Instrument Company in the United States and/or other countries. All other trademarks mentioned in the operating instructions are the exclusive property of the respective manufacturers.

iX77<sup>®</sup> is a trademark of Fann Instrument Company.

**Contact FANN****Phone**

TELEPHONE: 281-871-4482  
TOLL FREE: 800-347-0450  
FAX: 281-871-4358

**Mail**

Fann Instrument Company  
P.O. Box 4350  
Houston, Texas, 77210 USA

**Location**

Fann Instrument Company  
14851 Milner Road, Gate 5  
Houston, Texas 77032, USA

**Online**

[www.fann.com](http://www.fann.com)  
[fannmail@fann.com](mailto:fannmail@fann.com)

**Table of Contents**

**1 Introduction to the iX77™ Rheometer .....1**

1.1 Function .....1

1.2 Test Design Principles .....2

1.3 Document Conventions .....4

**2 Safety .....5**

2.1 Machine Hazard .....5

2.2 Ergonomic Considerations.....6

2.3 Environmental Considerations .....6

**3 Features and Specifications .....7**

3.1 Mechanical .....7

3.2 Controls.....9

3.3 Software .....12

**4 Installation .....35**

4.1 Main Instrument.....35

4.2 Test Cell Preparation Stand.....38

**5 Operation .....39**

5.1 Software .....39

5.2 Test Preparation – Mechanical .....61

5.3 Test Procedure – Mechanical .....69

5.4 Test Cell – Mechanical .....74

5.5 Calibration – Mechanical .....93

5.6 Chiller Operation .....101

**6 Analyzing Results.....103**

**7 Troubleshooting and Maintenance.....104**

7.1 Pressure.....104

7.2 Tescom Valve Maintenance .....105

7.3 Temperature.....116

7.4 General .....117

**8 Accessories and Spare Parts .....119**

**9 Parts List.....121**

9.1 Mechanical Parts .....121

9.2 Electrical Parts .....136

9.3 Test Cell Assembly (101511610) Parts.....144

**10 Warranty and Returns .....148**  
 10.1 Warranty..... 148  
 10.2 Returns..... 148

**List of Figures**

Figure 7-1 Rear Fluid Connections..... 105  
 Figure 7-2 Drawer Latch Location..... 106  
 Figure 7-3 Opened Drawer with Rotated Front Panel ..... 106  
 Figure 7-4 Control Cable..... 107  
 Figure 7-5 Air Inlet Tubing ..... 107  
 Figure 7-6 Wrenches for Valve Disassembly ..... 108  
 Figure 7-7 Clearance in the Disassembling Area ..... 108  
 Figure 7-8 Body Assembly/Air Actuator Assembly ..... 109  
 Figure 7-9 Valve Disassembly ..... 109  
 Figure 7-10 Air Actuator Assembly..... 110  
 Figure 7-11 Internal Sensor Assembly Location..... 111  
 Figure 7-12 Internal Sensor Assembly Removal ..... 111  
 Figure 7-13 Seat Retainer ..... 111  
 Figure 7-14 Lubrication of Threads ..... 112  
 Figure 7-15 Torque Sensor Tool ..... 112  
 Figure 7-16 Soft Jaws ..... 113  
 Figure 7-17 Spring Pad..... 113  
 Figure 7-18 Valve Parts ..... 114  
 Figure 7-19 Stem and Spring ..... 114  
 Figure 7-20 O-ring and Backup Ring..... 114  
 Figure 7-21 Loctite Application..... 115  
 Figure 7-22 Reassembled Sensor..... 115  
 Figure 7-23 Lubricated Threads..... 115  
 Table 9-2 Mechanical Assembly, P/N 101516396, Rev N..... 122  
 Figure 9-1 iX77 Mechanical Assembly, Front & Back View, Rev J ..... 128  
 Figure 9-2 iX77 Mechanical Assembly, Inside View, Rev J ..... 129  
 Figure 9-3 iX77 Mechanical, Tower Assembly, Rev J..... 130  
 Figure 9-4 iX77 Mechanical, Hydraulic Piping, High Pressure, Rev J..... 131  
 Figure 9-5 iX77 Mechanical, Hydraulic Piping, Low Pressure, Rev J..... 132  
 Figure 9-6 iX77 Mechanical, Water Piping, Rev J ..... 133  
 Figure 9-7 iX77 Mechanical, Chiller Piping, Rev J..... 134  
 Figure 9-8 iX77 Mechanical, Electrical Components, Rev J ..... 135

Figure 9-9 iX77 Electrical Assembly, Main Components, Rev H ..... 139  
 Figure 9-10 iX77 Electrical Assembly, Din Rail Components, Rev H..... 140  
 Figure 9-11 iX77 AC System Wiring Diagram, Rev J..... 141  
 Figure 9-12 iX77 DC Wiring System, Rev J..... 142  
 Figure 9-13 iX77 Mechanical Schematic, Rev B..... 143  
 Figure 9-14 iX77 Cell Assembly, Rev E ..... 145  
 Figure 9-15 iX77 Cell Cup, Rotor, Coupling, Shaft & Bob, Rev E ..... 146  
 Figure 9-16 iX77 Torsion Module and Top Jewel Assemblies, Rev E..... 147

## List of Tables

Table 3-1 Instrument Specifications.....7  
 Table 3-2 Computer Requirements..... 13  
 Table 5-1 Torsion Spring Modules ..... 78  
 Table 7-1 Pressure ..... 104  
 Table 7-2 Temperature ..... 116  
 Table 7-3 General..... 117  
 Table 8-1 Accessory Parts Kit, P/N 101625874, Rev I..... 119  
 Table 8-2 iX77 Rheometer Tool Kit, P/N 101623037, Rev B..... 120  
 Table 9-1 iX77 Rheometer, P/N 101543382, Rev G ..... 121  
 Table 9-3 iX77 Chassis Assembly, Mechanical, P/N 101514170, Rev J..... 125  
 Table 9-4 iX77, Tower Rotational Assembly, P/N 101514172, Rev. E ..... 126  
 Table 9-5 iX77, Drive Can Assembly, P/N 101516026, Rev E ..... 126  
 Table 9-6 iX77, Drive Can Set, P/N 101543354, Rev A ..... 127  
 Table 9-7 iX77 Electrical Assembly, P/N 101531615, Rev M..... 136  
 Table 9-8 iX77 Top Fab Assembly, P/N 101531616, Rev D ..... 138  
 Table 9-9 iX77 Cell Assembly, P/N 101511610, Rev E..... 144

## 1 Introduction to the iX77™ Rheometer

The iX77™ Rheometer is a coaxial cylinder type that was developed to measure fluid rheologies under high pressures and temperatures with a high degree of safety. The FANN<sup>®</sup> design is based on a machine developed by the Sandia National Laboratories. It was designed with oil well and geothermal drilling fluids in mind but has applications in many other fields. It features extensive safety interlocks through not only the internally mounted computer but also mechanical and smart electronic hardware.



DO NOT TEST hematite, limonite, FeCO<sub>3</sub> or other magnetic and/or ferrous containing compounds, solutions, suspensions, elixirs, etc.

### 1.1 Function

Specifications of the iX77™ allow operation to 600°F (316°C) and 30,000 psig (206,840 kPa). Optionally, a chiller may be attached and controlled by the software to allow operation below lab temperatures.

The control software is intended to automate the operation, data collection, reporting and notification functions of the iX77 Rheometer to the greatest extent practical, thus allowing the operator maximum flexibility.

The goal in designing the software was to automate as much as possible, while still permitting the machine to be configured and operated as needed by an advanced user.

The one-piece bench top design makes it suitable for use on a well site as well as in a laboratory. Special consideration should be given for moving and installing this instrument because of its weight (350 lbs) and its stature. A strong low-profile (32 in) bench top is recommended for easier cell removal. It uses a unique magnetic sensor to detect the motion of the jewel mounted torsion assembly in the test cell. The sensor system can be calibrated to ± one degree (equivalent to one centipoise at 300 RPM).

Test pressures are generated by an air-operated high-pressure hydraulic pump and controlled by a smart back pressure controller, high-pressure valve and pressure transducer. The pressurization fluid fills the upper portion of the test cell. The pressurization fluid is in direct contact with the quiescent sample, above the sample in the measurement area. The contact area is small to minimize mixing.



The inlet air pressure must be quickly supplied to the system through a quarter turn valve or a push-on quick connect.

The inlet air Filter/Dryer/Regulator system has an automatic drain that vents through the system drain when excess water is detected. When the inlet air is initially supplied, the automatic drain is open and requires a quick pressure input to cause the automatic drain to seat.

## 1.2 Test Design Principles

Careful test design will avoid many problems, including test repetitions, and will minimize test time. The following principles should be followed while designing a test.

### 1.2.1 Select the Proper Pressurization Fluid

Thoughtful selection of the pressurization fluid will help prevent false test results. Two choices are available:

1. The pressurization fluid can be the same as the sample if it is free of suspended solids and has minimal gelling tendencies. Suspended solids would quickly damage the pumping and venting system by eroding the sealing surfaces. If the fluid gelled around the torsion assembly, it would cause inaccurate measurements.
2. The pressurization fluid must be of lower density than the sample (lower specific gravity) and immiscible in the sample so that it will float on the top of the sample without mixing.

It is also desirable to use a pressurization fluid that has a high flash point and low toxicity. For example, some users have been using Dow Corning's SYLTHERM™ 800 Heat Transfer Fluid for both oil- and water-based drilling fluids, to their satisfaction.

Rheometer Head Oil (P/N 207874) may be satisfactory for use with many water-based drilling fluids, and possibly oil-based fluids. Dow Chemical Company's Polyglycol 112-2 has been suggested as another possible candidate for both oil- and water-based drilling fluid applications.

The user should conduct a test to determine the pressurization fluid's compatibility with the sample. Use a syringe (with long blunt needle) to extract a sample from the bottom of the sample cup, avoiding the top layer that contains pressurization fluid. This post-test sample of the tested fluid could be analyzed for contamination. .

### 1.2.2 Detect Malfunctions Early

An initial pressurization leak test, a "startup" test, and an "end" test are recommended. This startup test and end test can be incorporated in your test sequence. Normally, the startup test should be conducted at near-ambient conditions, such as between 120°F and 150°F (50°C to 65°C) and 300 psig (2000 kPa). The

purpose of the startup test is to verify proper operation of the instrument. Before proceeding, the operator should determine if the readings obtained at startup compare favorably with measurements taken at the same temperature in an unpressurized instrument. A FANN<sup>®</sup> Model 34 or 35 Rheometer or RheoVADR™ Rheometer could be used for this purpose. The reference and startup test should be conducted at the same temperature.

The end test should be conducted with the same conditions as the startup test. It will aid in detecting sample contamination by the pressurization fluid and permanent sample changes caused by the combinations of temperature, pressure, and shear used during the test.

### 1.2.3 Minimize Temperature Changes

Temperature changes are time consuming because of the system's high thermal lag. A temperature tolerance should be preselected and used uniformly. Normally  $\pm 3^{\circ}\text{F}$  ( $\pm 2^{\circ}\text{C}$ ) is adequate. Measurements should be taken as long as the test is within the temperature tolerance (and pressure tolerance). Don't wait for the exact temperature. Select meaningful temperature steps.



---

Experience has shown that temperature changes of less than  $50^{\circ}\text{F}$  ( $28^{\circ}\text{C}$ ) are rarely useful.

---

### 1.2.4 Minimize Pressure Adjustments

The system pressure will rise with temperature due to the sample's expansion. With experience, a pressure can be selected before heating which will result in a pressure slightly below the desired pressure after heating. The pressure is automatically controlled to within  $\pm 100$  psi, regardless of the pressure or temperature setting.

With most samples, temperature has a much greater effect on their properties than pressure. For this reason, pressure changes of less than 1,000 psig (6,895 kPa) are rarely useful. Note the resolution of the pressure display is  $\pm 1$  psig.

### 1.2.5 Temperature and Pressure Variations

Consider varying only the temperature or pressure between data points. It is easier to recognize unusual behavior or equipment malfunction if only one variable is changed at a time.



### 1.3 Document Conventions

The following icons are used in this manual as necessary.



**NOTE.** Notes emphasize additional information that may be useful to the reader.



**CAUTION.** Describes a situation or practice that requires operator awareness or action in order to avoid undesirable consequences.



**MANDATORY ACTION.** Gives directions that, if not observed, could result in loss of data or in damage to equipment.



**WARNING!** Describes an unsafe condition or practice that if not corrected, could result in personal injury or threat to health.



**ELECTRICITY WARNING!** Alerts the operator that there is risk of electric shock.



**HOT SURFACE!** Alerts the operator that there is a hot surface and that there is risk of getting burned if the surface is touched.



**EXPLOSION RISK!** Alerts the operator that there is risk of explosion.

## 2 Safety

### 2.1 Machine Hazard

#### 2.1.1 Mechanical

- The Rheometer is routinely subjected to high pressure. Therefore, all fittings and couplings must not be tampered with until the pressure has been relieved to zero. This hazard is particularly enhanced when the covers are removed.
- The cell and shield have been designed to assure safety. However, all high-pressure equipment should be treated with great respect for the potential for destruction that it has.



---

The cell is most dangerous when filled with hot water-based fluids. A major failure of the test cell at high temperature and pressure would result in the explosive release of the contained energy. At 30,000 psig and 600°F, the water-filled test cell has more energy than if it were filled with nitrogen gas under those same conditions. Care must be taken to assure that the cell is not mistreated.

---



---

Failure to follow all instructions and exercise appropriate precautions could produce a catastrophic failure of pressure system integrity without warning and result in serious injury or death.

---

- Before testing a new fluid sample in the test cell, be sure that it is compatible with the metals used in its construction. Corrosion pits would render the cell unsafe.

#### 2.1.2 Temperature

- The Rheometer is routinely subjected to high temperatures. The closed shield prevents accidental contact with the hot parts. However, if the shield is opened prior to cooling down, there is nothing to prevent a person from touching the hot cell or the heater well plate upon which it sits. We recommend that the shield not be opened until the cell has cooled to at least 100°F (38°C) and the pressure has been completely relieved.
- If the Rheometer is depressurized before the sample has cooled enough, the possibility exists that the sample would flash to vapor, leading to possible injury.

- During a water cool down, hot water is expelled from the drain hose on the iX77. The first few minutes of a high-temperature cool down are somewhat vigorous, and the drain will emit steam and occasionally sputter boiling water. Be sure that the vent hose is secured so that no one will be splashed.
- The sample being tested and the pressurization fluid used in the pump may be flammable. In the case of a seal failure, these flammable liquids could hit a hot surface within the shield and present a fire hazard. The location of the test system should be selected with that in mind. Appropriate fire extinguishing equipment should be nearby and the operators trained in its use.

### 2.1.3 Electrical

- The covers serve to separate the user from potential high pressure, electric shock, rotating parts, high temperature and other hazards. The covers must be in place for normal use, and should not be removed except when maintenance is being performed. When the covers are removed, many hazards exist and extraordinary care must be exercised to prevent injury.

## 2.2 Ergonomic Considerations

- Special consideration should be given for moving and installing the iX77 because of its weight (350 lbs) and its stature.
- A strong low-profile (32 in) bench top is recommended for easier cell removal

## 2.3 Environmental Considerations

Properly dispose of pressurizing fluids and testing samples.

### 3 Features and Specifications

#### 3.1 Mechanical

##### 3.1.1 Instrument Specifications



These instrument specifications are for standard R1 rotor, B1 bob, and F1 torsion spring module.

**Table 3-1 Instrument Specifications**

Instrument Geometry	Coaxial Cylinder
Rotor Speed, RPM (normal)	1 to 600
Rotor Radius, cm	1.8415
Bob Radius, cm	1.7245 (B1 Bob)
Bob Height, cm	3.805 (B1 Bob)
Shear Gap in Annulus, cm	.1168
Torsion Spring constant, $K_1$ N-cm/degree deflection	0.00386 (F1 Torsion Spring)
Bob Surface constant, $K_2$ cm <sup>-3</sup>	0.01323 (B1 Bob)
Shear Rate constant, $K_3$ sec <sup>-1</sup> per RPM	1.7023
Overall Instrument Constant, K centipoise-RPM/degree	300
Shear Stress Accuracy	± 0.5% F.S
Maximum Use Temperature, F° (C°)	600° (316°C)
Minimum Use Temperature, F° (C°)	23° (-5°C)
Maximum Use Pressure, psi, kPa	30,000 (206843 kPa, 2041 atm)
Sample Volume	7.76 in <sup>3</sup> (175 cm <sup>3</sup> ) (nominal)
Power	230 V, 60/50 Hz, 1 KVA
Viscosity Range, cP	0–300 @ 300 RPM
Minimum Viscosity, cP	5 @ 600 RPM
Maximum Viscosity, cP	300 @ 300 RPM

Instrument Size and Weight	
Test Cell Size, inches, (cm)	16-1/4 high, 4-3/4 diameter (41.3 X 12.1 cm)
Weight, pounds (kg)	36 (16.4 kg)
iX77™ size, inches (cm)	41-1/2H,43-1/2W,24D (105.4x110.5x61cm)
Weight, pounds (kg)	350 (159 kg)

3.1.2 Test Cell Materials

The test cell is made up of three primary parts: the cap (top) the coupling (center) and the cell (bottom), all three made of INCONEL<sup>®</sup> 718 Solution. It is in the annealed, age-hardened condition, 44-46 HRC with a minimum 160KSI yield strength. These parts must be non-magnetic for proper functioning of the magnetic drive and torque sensing.

The pivot/thermowell in the inside center of the cell is made of 17-4PH stainless steel (17 Cr - 4 Ni - 4 Cu) bar stock in the age-hardened condition H 1150-m. The bottom portion of it acts as a pressure plug.

Three port adapters screw into the high-pressure ports of the test cell and are made of 17-4 PH stainless steel. The one used in the sample port would normally come in contact with the fluid at relatively low temperatures.

In normal operation, only the coupling, pivot/thermowell, and cell come in contact with the test fluids.

Most of the internal non-pressure containing parts of the test cell are made of 303 stainless steel.



The numbers in brackets [ ] refer to Drawing: 101511610.PDF.

The exceptions are described as follows.

In the bottom of the test cell in normal contact with the sample:

- Sapphire vee jewel [15]
- Tungsten carbide pivot [13, 30-2]
- Bushing [12] (wearing part—replace as required two-piece inner and outer race)
- Bronze rotor bushing [8] (wearing part replace as required)

- Samarium-cobalt, rare earth driven magnet [6]
- 17-4PH stainless steel pivot bushing [10] (wearing part—replace as required)
- 17-4PH stainless steel backup ring [43]
- Titanium bob shaft [17]

In the top portion of the test cell where these parts normally contact only the pressurization fluid:

- Alnico V upper torsion magnet [34]
- Sapphire vee jewel [15]
- Tungsten carbide pivot [13, 30-2]
- Titanium upper magnet mount [32] and limit stop [24]
- Beryllium-copper torsion spring [30-7] and jewel spring holder [35]
- Aluminum - spring mandrels [30-3,-4,-5], clamping sleeves [31, 30-6], and the zeroing sleeve [37]
- 17-4PH stainless steel backup ring [42]

## 3.2 Controls

### 3.2.1 Temperature Control

Test sample heating is produced by an electric resistance heater attached to the wall of the heater well. During a test, the sample portion of the test cell rests in the heater well. Heat transfers through a narrow gap from the wall of the heater well directly to the wall of the test cell. The heater is rated at 700 watts, 115 VAC with a built-in thermocouple. The unit operates using 230 VAC; the heater temperature is monitored and automatically controlled to a limit not to exceed 750°F allowing the lower-voltage heater to be safely used.

The sample temperature is sensed by means of a single J type thermocouple that is permanently mounted in the center of the heating well. It projects up from the center bottom of the well. It fits into the thermowell in the test cell as the cell is lowered into the heater well. The thermowell is located in the center of the rotor pivot, which supports the rotor (outer rotating cylinder). This places it near the center of the fluid sample.

There is considerable thermal lag in the system. The lag is also influenced by the properties of the test fluid and the rate of shear. Normally, the sample is sheared constantly to aid in minimizing the thermal lag. This allows the external flutes on the rotor to

generate flow up the inside wall of the test cell. It then flows down through the baffle, the center of the bob (the stationary part of the concentric cylinders), and the holes near the bottom of the rotor. The holes direct it back to the wall to recirculate.

The sample thermocouple has multiple safety features integrated through the user interface for multiple failure detection as well as an independent watchdog circuit that turns the motor and heater off in the case of a failure that is not sensed by the software.

Cooling is accomplished by injecting a flow-controlled flow of tap water or other coolant into the narrow gap between the test cell and the heater well. The expended steam and water is vented through a drain in the bottom center of the heater well. The top of the gap is lightly sealed by an O-ring that is retained on the test cell and seals against the top of the heater well. The same control system is used for both heating and cooling. The cooling is activated automatically when a lower-temperature set point is entered or the end of the test has been reached. The software will automatically turn on the air or water depending on preset default values. The cooling feature is primarily intended to rapidly cool the test cell at the end of a test, but it can also be used for a lower temperature set point. Temperatures below ambient can be reached by connecting an external chiller. The software will control the chiller automatically, allowing for total automatic cooling and heating integration in the test sequence.

### 3.2.2 Shear Rate Control

The rotor is magnetically driven through the wall of the test cell. A powerful samarium-cobalt permanent magnet is attached to the bottom of the rotor. It magnetically locks to a cylindrical permanent magnet, which rotates with an insulating can, around the heaters of the heater well. The insulating can is driven through a 10:1 off-the-shelf right-angle box with a brushless servo-motor and integrated drive. The motor's speed is internally sensed and fed back to the control systems. The speed response of the system is relatively rapid. Speed regulation is  $\pm .5$  revolutions per minute.

Any rotor speed between 1 and 600 RPM is available, including standard 600, 300, 200, 100, 6 and 3 RPM, which is equal to 1021, 511, 340, 172, 10.2 and 5.1 reciprocal seconds ( $S^{-1}$ ).

### 3.2.3 Pressure Control and Measurement

Test sample pressurization is achieved by a Maxpro Technologies Maximator air-operated gate-valve controlled piston pump, with a 1:440 air input to hydraulic output pressure ratio. The air pressure to this pump is controlled by a SMC Electro-Pneumatic

Proportional Valve for reaching the pressure with minimal overshoot. The pressure is then finely controlled by a Tescom<sup>™</sup> Smart Controller ER3000 coupled with a Tescom 30,000 psi Back Pressure Air-Op Valve and a Pressure Transducer. The Air-Op Valve is protected from solids during the pressure control sequence with an inline 30,000 psi filter with replaceable cartridge media.

Pressure release is primarily through a high-pressure air-operated non-rotating stem valve that is operated as a dump valve at the end of the test and activated through a solenoid valve. The air control valve and the dump valve, which are air controlled, are protected with check valves so pressure is not lost due to an unplanned power or air loss. A high-pressure manual valve is also provided and is primarily used to purge the system if a loss of pressure occurs while heating to expel any whole mud out of the system without damaging the control valves. The manual valve could also be used if all other systems failed to safely remove pressure from the system. A nominal 35,000 psig replaceable rupture disc provides additional safety relief. All released pressurization fluids are returned to the waste bottle.

Pressure measurement is made using a strain gauge transducer that is continually monitored by the Smart Controller and then sent to an I/O module to be processed by the program and displayed on the computer. Pressure readings are compared against both current set points and absolute safety limits. When the pressure is more than  $\pm 100$  psig below or above, the pressure system decides to increase or decrease pressure.

Pressurizing fluids used must be compatible with type 303 stainless steel. Consult an engineering handbook or the fluid manufacturer to verify the compatibility of a specific fluid. Any fluid used must be free of suspended solids. Solids could erode the pump and cause failure. Any of the following hydraulic fluids may be used:

1. Water
2. Soluble oil; an oil-in-water emulsion
3. Petroleum (hydraulic oils)
4. Emulsion; water-in-oil
5. Water-glycols
6. Poly-glycols



### 3.3 Software

#### 3.3.1 Functional Overview

The iX77 Rheometer version 1.1 software runs on the Windows<sup>®</sup> XP operating system, and was developed using National Instruments LabVIEW. The control system hardware components are readily available.

The iX77 Rheometer controls and records temperature, pressure, and rotor speed. It derives all of the fluid property measurements from the angle of rotation of the internal bob, as reported by the magnetometer and calibrated using a standard fluid. There are two data collection modes, manual and automatic. In manual mode, the user turns on data collection from the screen and provides the necessary set points. In the automatic mode, a test profile is either generated from a list of pressure and temperature test points or retrieved from a file. The automatic profile generation is based on a template set up by the installer. In addition to the testing functions, the software provides for calibration, setup, and tuning to allow the iX77 Rheometer to be used for a wide variety of tests.

The shear stress values are calculated based on a look up table developed during calibration. The calibration file is loaded on startup, and evaluated for evidence of hysteresis. Excessive hysteresis indicates a likely mechanical problem, and a dialog is displayed when it is detected.

The software may be run in “Simulation Mode” for training and support purposes. In this mode, the software “pretends” that it is a fully functional iX77 Rheometer. This mode is for training and support purposes only, and the results generated should never be construed as meaningful.

If the system starts up and detects it is under pressure (for instance after a power failure), it will use the detected pressure as its manual pressure set point. This is done to avoid decompressing the system suddenly. Temperature set point is always set to zero on startup.

Provision has been made to control an external Chiller by connecting via a serial cable to the chiller. The operational parameters for using the chiller will be set up by the installer.

Optional Chiller:

- 204160 115 VAC 60 Hz
- 381464 230 VAC 50 Hz

## 3.3.2 Computer Requirements (internal; supplied with unit)

**Table 3-2 Computer Requirements**

Requirement	Type
Processor	P4 or equivalent
Memory	512 MB (1 GB or more recommended)
Hard Disk	20 GB (Larger recommended)
Operating System	Windows <sup>®</sup> XP
Other	Full height PCI slot available 3 USB 2.0 ports available

## 3.3.3 User Requirements

It is assumed that the user has an excellent working knowledge of personal computers and the Windows operating system. It is further assumed that the user is a trained laboratory technician with experience in drilling fluid testing. Specifically, the user is expected to be capable of:

1. Preparing a sample and setting up the iX77™ Rheometer mechanically for the test
2. Starting a program from a screen icon
3. Sending and receiving email
4. Locating and copying files on the computer
5. Using a spreadsheet or other program to create presentation quality reports from gathered data
6. Performing other basic windows tasks (minimize, maximize, etc.)

## 3.3.4 Installer Requirements

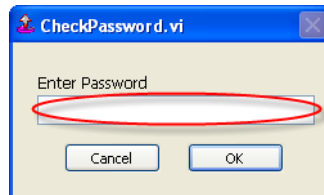
These requirements are at the time of manufacturing or reinstall due to hardware replacement. It is assumed that the person installing the DAQ hardware and software has the skills of a good PC technician. Specifically, the installer is expected to be capable of:

1. Meeting all of the requirements of a user above
2. Installing USB DAQ devices
3. Installing driver software
4. Installing application software
5. Editing INI files to alter program setup

3.3.5 Entering Technician Mode

3.3.5.1 Click the **Enter Technician Mode** button on the **Calibration** tab.

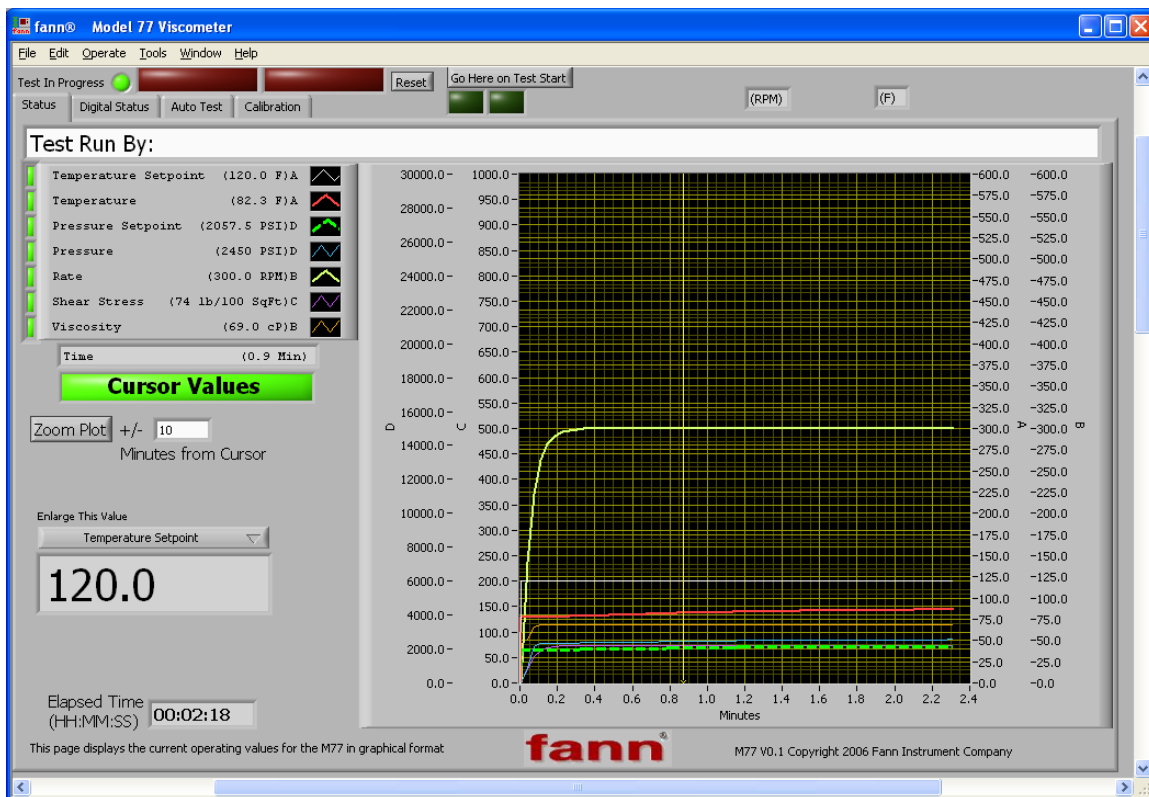
3.3.5.2 Enter the password (assigned by the installer).



**Figure 3-1 Enter password**

3.3.5.3 To leave technician mode, click the **Leave Technician Mode** button on the **Status** tab or simply wait until the preset time has expired. This time defaults to 60 seconds but may be changed by the installer.

3.3.6 Additional Functions on the Status Tab



**Figure 3-2 Cursor Values**

The **Status** tab has the following convenience features:

**Cursor**

- The cursor will be at the far left of the main plot on startup but can be dragged to any position of interest.
- Dragging the cursor illuminates the **Cursor Values** enunciator and activates the display of those values on the box next to the plot.

**Zoom Plot**

- Clicking this button will display a plot of the data “zoomed” to a region around the cursor  $\pm$  the number of minutes in the **Minutes from Cursor** box.

**Clear Plot**

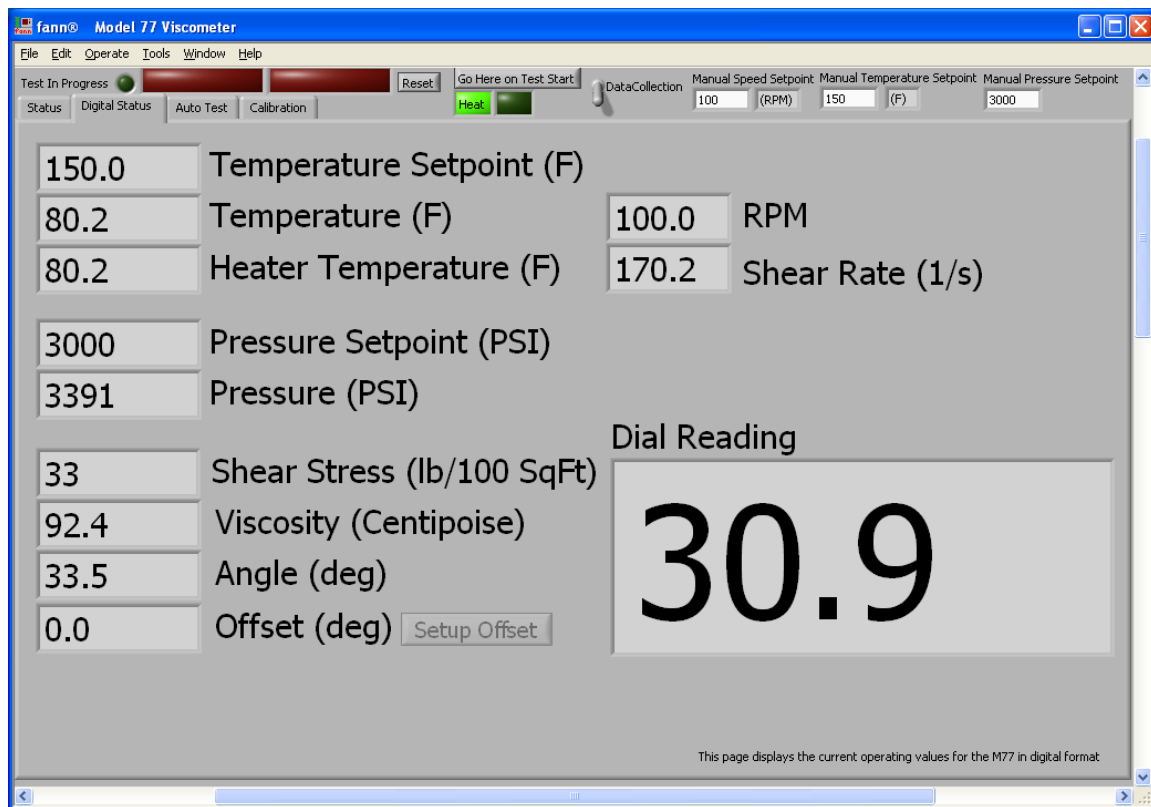
- This button is hidden while data is being collected.
- It is used to clear the graph area if desired.

**Enlarge This Value**

- This is a drop down list that allows the user to choose one value from the list and display it in an enlarged font.
- This is intended to assist the user in viewing the screen from a distance if needed.

## 3.3.7 Information on the Digital Status tab

The **Digital Status** tab is provided for those users who prefer a numerical display to the graphic display on the **Status** tab.



**Figure 3-3 Digital Status tab**

#### **Temperature Setpoint**

- This is the temperature that the system is currently trying to achieve.

#### **Temperature**

- This is the current temperature of the sample thermocouple.

#### **Heater Temperature**

- This is the current internal temperature of the heater.
- This is only used for system tuning and diagnosis; it does not indicate sample temperature.

#### **Pressure Setpoint**

- This is the pressure that the system is currently trying to achieve.

#### **Pressure**

- This is the current pressure of the sample.

#### **Shear Stress**

- This is the current shear stress measured and calculated by the system.

**Viscosity**

- This is the current viscosity measured and calculated by the system.

**Angle**

- This is the current angle of rotation of the bob from the mechanical zero position.
- This angle is used in conjunction with the calibration table to calculate Shear Stress, Viscosity, and Dial Reading.

**Offset (Setup Offset)**

- This is used to account for minor variations in mechanical setup and allow a small temporary adjustment of the zero point.

**RPM**

- This is the current rotational speed of the rotor.

**Shear Rate**

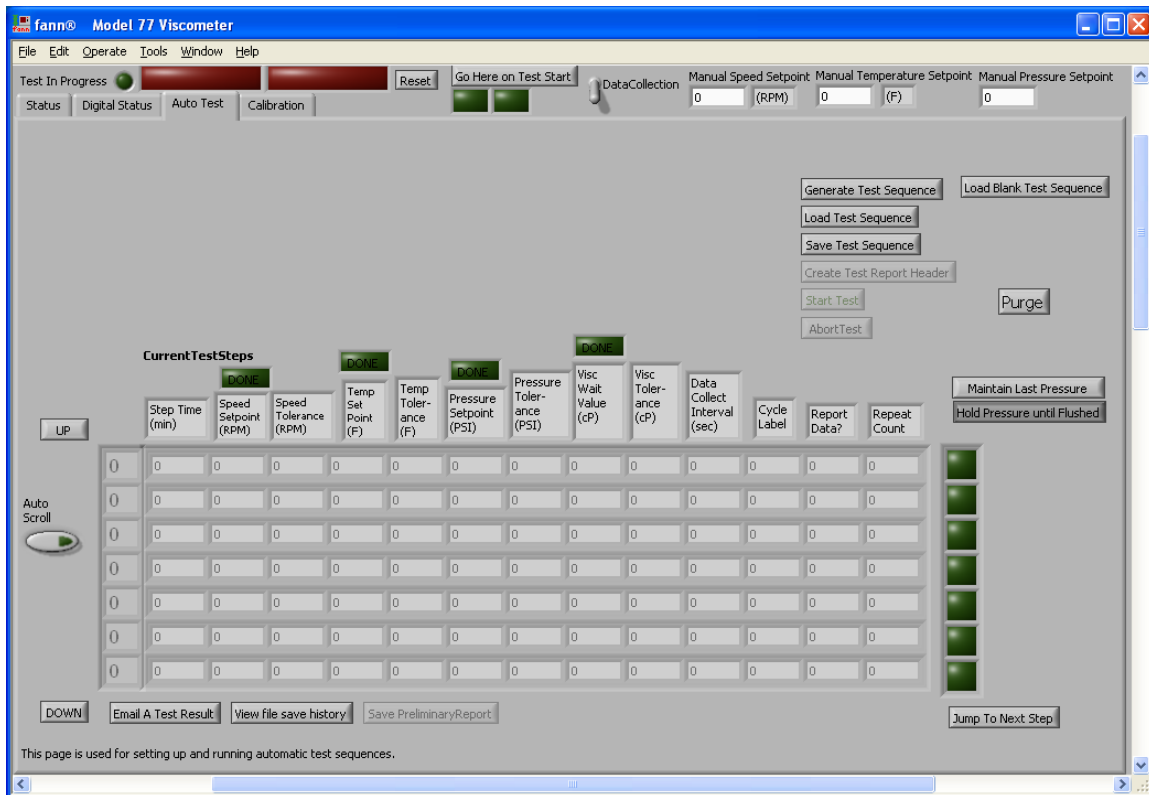
- This is the shear rate calculated from the mechanical geometry of the Rheometer using the RPM.

**Dial Reading**

- This is the equivalent value you would read on the dial of a FANN<sup>®</sup> Model 35 Rheometer under the current conditions.

**3.3.8 Options on the Auto Test tab**

There are additional functions available on the **Auto Test** tab that were not covered in the discussion of running an automatic test above.



**Figure 3-4 Auto Test tab options**

**Load Blank Test Sequence**

- This is used to clear out the current test steps.

**Purge**

- This initiates a purge cycle that helps purge air from the test chamber before pressurization.
- It is not required for routine operation.

**Up / Down**

- These buttons allow scrolling to view the all of the steps in a sequence.
- If Auto Scroll is lit and the test advances to a new step, that step will be placed at the top of the viewing area.

**Auto Scroll**

- Used to determine if the test step display is synchronized to the current test step.
- Auto Scroll is automatically turned off when Edit Lock is turned off.

**Edit Lock**

- Used to prevent accidental changes to test steps while a test is in progress.
- May be turned off to edit test steps while test is running.
- Edits to a running test are only effective for steps that have not yet been started.

**Email a Test Result**

- This allows the user to select a file on the local computer and send it to a specified email address.

**View File Save History**

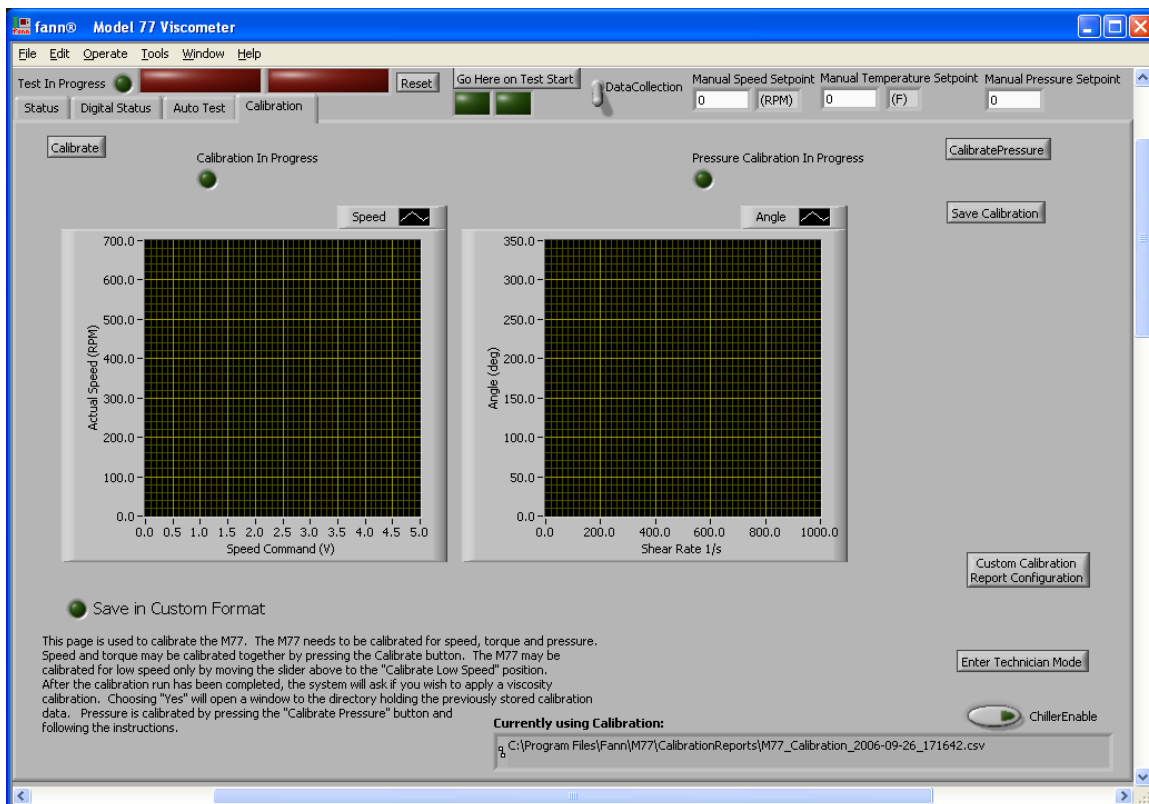
- This allows the user to see the full path of the last one hundred files written by the software.

**Save Preliminary Report**

- This allows the user to generate an interim report before the test is completed.

3.3.9 Options on the Calibration Tab

There are options available on the **Calibration** tab that were not described in **Calibrating** above.



**Figure 3-5 Calibration tab options**



**Custom Calibration Report Configuration**

- This allows the user to specify an alternate format for the calibration report.
- If Save in Custom Format is illuminated, this produces a second customized calibration report for importing into legacy programs for analysis.

**Save in Custom Format**

- This instructs the system to save a second copy of the calibration report in a custom format.

**Chiller Enable**

- When illuminated, this tells the system to use an external chiller to cool the system as needed to achieve temperature.

**Currently using Calibration:**

- This is the full path name of the calibration file currently in use.
- If the default name is used, it will include the time and date of the calibration.

### 3.3.10 The Setup Tab (Technician Mode)

This tab allows access to the parameters that adjust the operation of the iX77 Rheometer. It is vital for both safety and proper function that these parameters are only changed by an experienced technician. If you are not absolutely certain that you should change any of these parameters, don't.

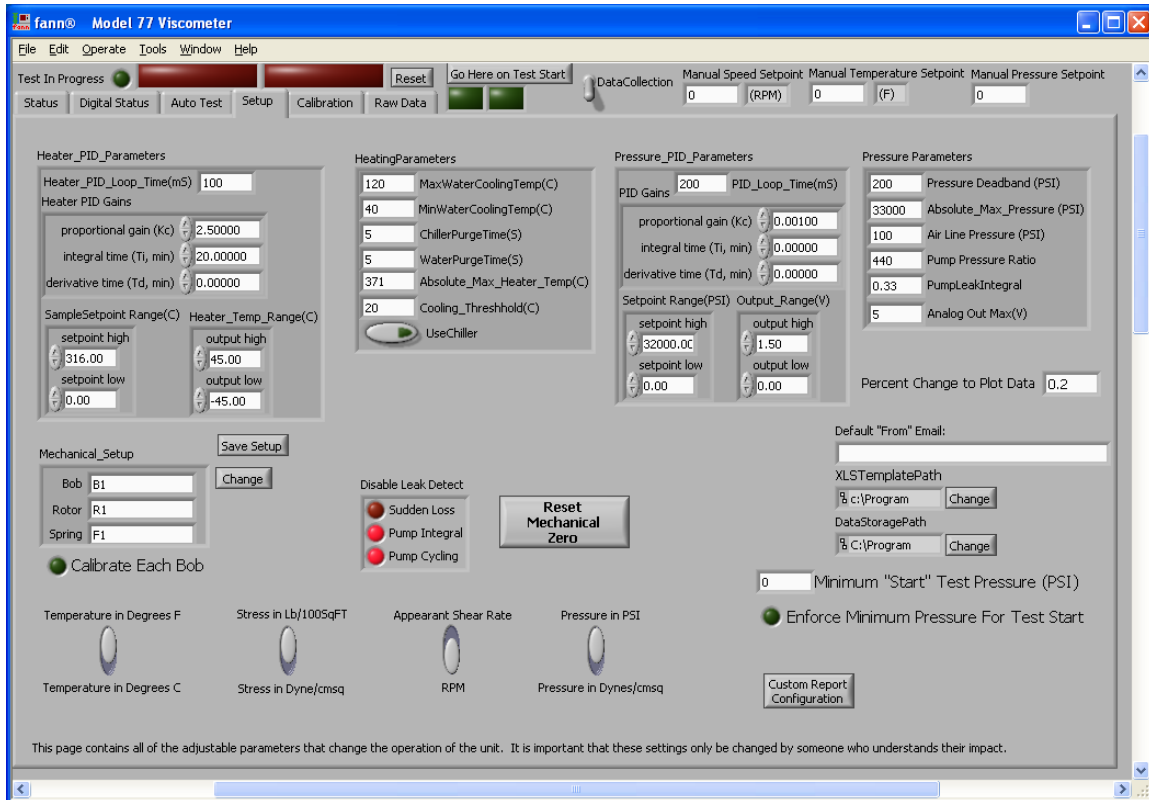


Figure 3-6 Setup tab

3.3.11 Information on the Raw Data Tab (Technician Mode)

This tab displays information that will be helpful to an installer or technician in troubleshooting the iX77 Rheometer. It should not be needed for routine operation of the iX77 Rheometer.

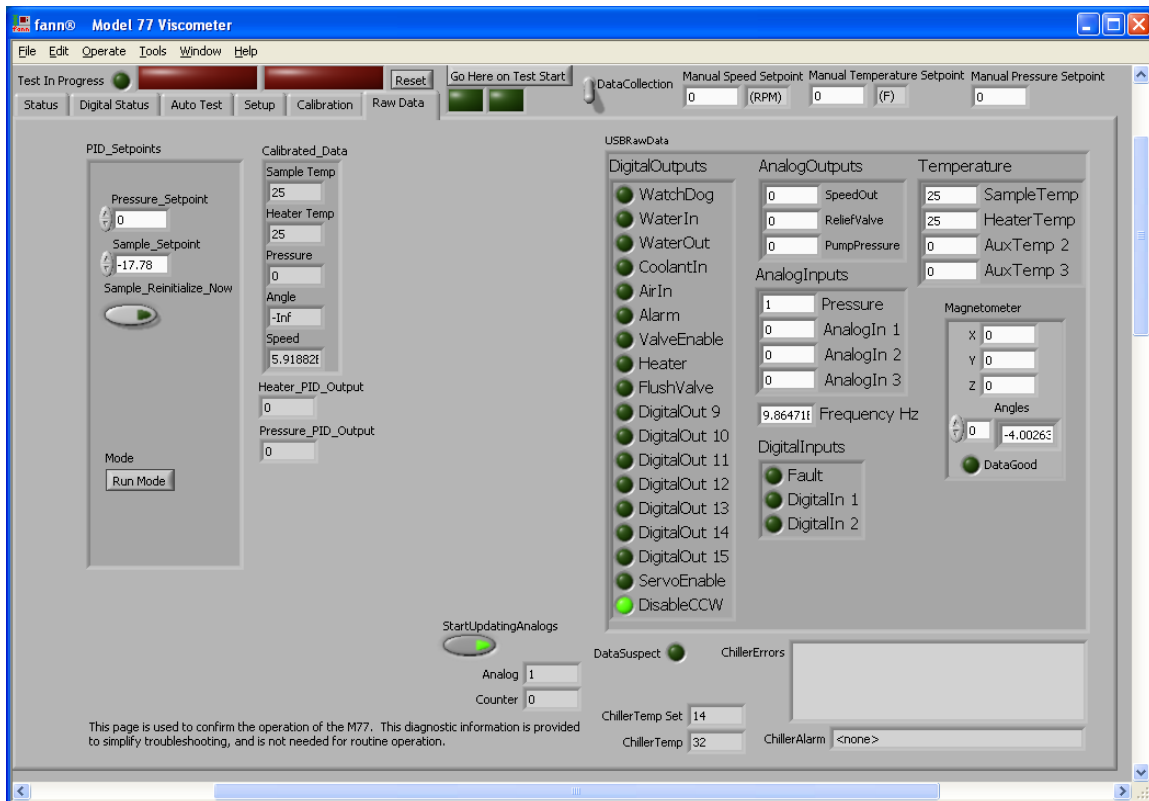


Figure 3-7 Raw Data tab

### 3.3.12 iX77 Rheometer Program Resources

The software uses various resources while running. Of particular interest are the files used to store various operating parameters, test profiles, and reported data.

These files are organized under the Program Files\Fann\... family of directories (where the **Program Files** directory is the Windows **Program Files** directory, i.e. "C:\Program Files\").

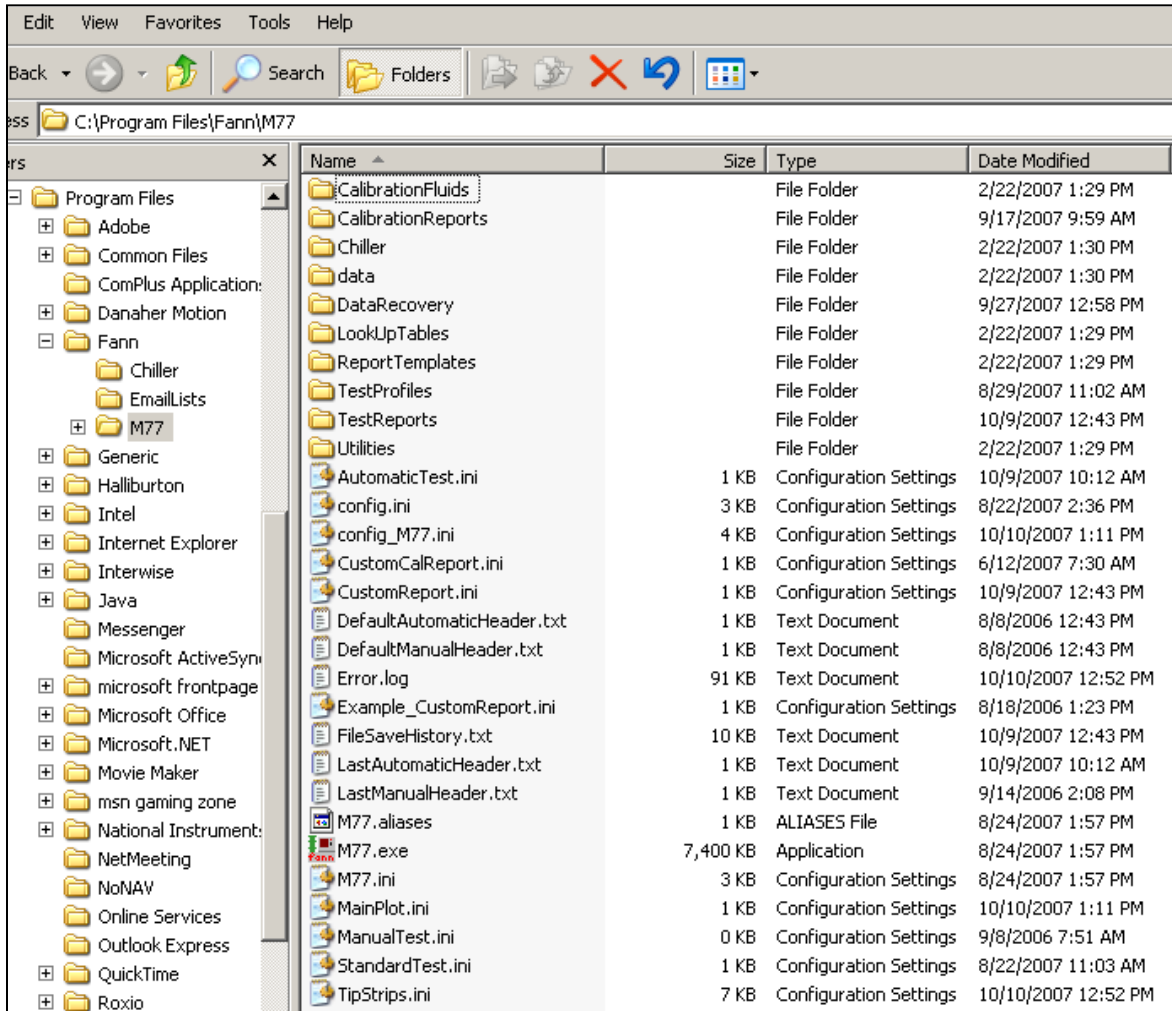


Figure 3-8 Directory structure

#### 3.3.12.1 Files located in C:\Program Files\Fann\EmailLists\

##### Email.ini

- This file contains all of the setup information for automatic and manual email notifications. This file must be edited by installer to enable email functionality.

### 3.3.12.2 Folders located in C:\Program Files\Fann \M77\

#### **CalibrationFluids\**

- This folder contains all of the calibration fluid data files.
- Calibration fluid files may be added either by downloading or creating them locally.

#### **CalibrationReports\**

- This folder is the default location for all of the calibration reports.
- The system creates these reports for you.
- There should be at least one file in this folder for the system to use as a look up table.

#### **Chiller\**

- This folder contains the configuration file for the chiller (config.ini.).

#### **Data\**

- This folder is used by the program exclusively.
- No changes of any kind should ever be made manually to anything in this folder.

#### **DataRecovery\**

- This folder is used to store the data during the running of the test.
- If power fails while a test is running, the system will save a file in this folder on restart.
- If necessary, this file can be used to reconstruct a test report manually.

#### **LookUpTables\**

- This folder stores the optional lookup tables for the control system.
- These files should only be edited by a technician or installer.

#### **ReportTemplates\**

- This folder contains the report templates used to generate Excel spreadsheets.
- The **Basic.xlt** file may be replaced with one that has been optimized to produce a lab specific report.

- This requires a high level of expertise in setting up Excel templates, and thus is typically done by a factory technician.

**TestProfiles\**

- This folder contains the stored test sequences for running standard tests.
- These files may be edited by an advanced technician if that serves their purpose.

**TestReports\**

- This folder contains the test reports generated by the system.

**3.3.12.3 Individual files located in C:\Program Files\Fann \M77\****AutomaticTest.ini**

- This file retains the settings for reporting automatic tests.
- It should not require manual editing.

**Config.ini**

- This file contains the dimensional data for the rotor, bob, and spring used in the iX77 Rheometer.
- It should not require manual editing.

**Config\_M77.ini**

- This file contains the operational and setup information for the iX77 Rheometer.
- The system will generally maintain this file.
- There are some circumstances under which a trained technician or installer may need to edit this file.

**CustomCalReport.ini**

- This file contains the information used by the system to create the Custom Calibration Report.
- This file can be generated by the system or shared between labs to ensure a uniform report.

**CustomReport.ini**

- This file contains the information used by the system to create the Custom Report.

- This file can be generated by the system or shared between labs to ensure a uniform report.

**DefaultAutomaticHeader.txt**

- This file contains the text that is used in the header portion of a test report when **Remember Last Header** is NOT checked.
- This may be edited as desired (use Notepad to edit).

**DefaultManualHeader.txt**

- This file contains the text that is used in the header portion of a test report when **Remember Last Header** is NOT checked.
- This may be edited as desired (use Notepad to edit).

**Error.log**

- This file contains a log of the errors detected by the system.
- This file will be recreated if deleted.
- The latest error will be the first entry in the file.

**FileSaveHistory.txt**

- This file contains a list of the files that have been created by the software.
- This file will be recreated if deleted.
- The latest file will be the first entry in the file.

**LastAutomaticHeader.txt**

- This file contains the text that is used in the header portion of a test report when **Remember Last Header** is checked.
- This may be edited as desired (use Notepad to edit).

**LastManualHeader.txt**

- This file contains the text that is used in the header portion of a test report when **Remember Last Header** is NOT checked.
- This may be edited as desired (use Notepad to edit).

**M77.ini**

- This is a system file that should never be edited.

**MainPlot.ini**

- This file stores the settings for the main plot.
- This is not user editable.

**ManualTest.ini**

- This file retains the settings for reporting automatic tests.
- It should not require manual editing.

**StandardTest.ini**

- This file contains the information that determines how an automatic test sequence is generated.
- It can be edited by a skilled technician or installer.
- If this file is not found by the software when test generation is invoked, a dialog will appear that allows configuring the options.

**TipStrips.ini**

- This file contains the **Tip Strip** text for when the mouse hovers over a control on the software's front panel.
- This file may be edited by an experienced technician to allow the customization of the tips for an individual machine or lab.
- If this file is deleted, it will be recreated with the default values.

**3.3.13 Setup Glossary****3.3.13.1 Heater\_PID\_Parameters**

These parameters directly impact the heating performance of the Rheometer. These should not require adjustment. If a change to the system requires that these values be changed, it should be done by a trained technician.

**3.3.13.2 Pressure\_PID\_Parameters**

These parameters directly impact the pressurization performance of the Rheometer. These should not require adjustment. If a change to the system requires that these



values be changed, it should be done by a trained technician.

### 3.3.13.3 HeatingParameters

These values tell the Rheometer what temperatures to start and stop cooling and whether or not a chiller is present. It may be necessary from time to time for an experienced technician or installer to adjust some of these parameters.

- **MaxWaterCoolingTemp(C)** This is the maximum temperature at which water cooling will be used. If the system requires cooling above this temperature, it will use air. An experienced technician might adjust this parameter to achieve maximum cooling performance.
- **MinWaterCoolingTemp(C)** This is the minimum temperature at which water cooling will be used. If the system requires cooling below this temperature, it will use the chiller (if available and enabled). An experienced technician might adjust this parameter to achieve maximum cooling performance.
- **ChillerPurgeTime(s)** This is the number of seconds that the system will blow air after using the chiller in order to ensure that the coolant has been blown back into the chiller after use.
- **WaterPurgeTime(s)** This is the number of seconds that the system will blow air after using cooling water in order to ensure that the water has been blown out the drain after use.
- **Absolute\_Max\_Heater\_Temp(C)** This is the highest temperature that the system will allow the heater to achieve. Note that this is not the sample temperature. This should not be adjusted unless the heater has been replaced with one that has a different maximum temperature rating.
- **Cooling Threshold(C)** This is the number of degrees that the sample must be over the set point before cooling is used. An experienced technician might adjust this parameter to achieve maximum cooling performance.

- **UseChiller** This tells the system whether or not a chiller is present.

#### 3.3.13.4 Pressure Parameters

These values tell the Rheometer how to utilize the pumping and relief systems to regulate pressure. It may be necessary from time to time for an experienced technician or installer to adjust some of these parameters.

- **Pressure Deadband (psi)** How many psi the regulator will be set above the pump set point. This may be adjusted, but it can cause erratic performance if it is too high or too low.
- **Absolute\_Max\_Pressure (psi)** The highest value the system will let the relief valve to be set at. The only reason to change this would be to accommodate a hardware change.
- **Air Line Pressure (psi) Actual** pressure of the air supplied to the machine. This is used to scale the pump output value. This should be set by the installer.
- **Pump Pressure Ratio** The ratio input to output pressure on the high-pressure pump. Used for scaling the output. The only reason to change this would be to accommodate a hardware change.
- **PumpLeakIntegral** A number that represents how much pumping is allowed before the **Pump Integral** detects a leak. Adjusting this will affect the detection of leaks if the **Pump Integral** leak detect has not been disabled.
- **Analog Out Max(V)** Maximum voltage of the output to the pressure regulator. Used for scaling the output. The only reason to change this would be to accommodate a hardware change.

#### 3.3.13.5 Percent Change to Plot Data

The software waits until a measured or imposed parameter (shown on the main plot) has changed by at least this amount before recording data. If this value is set too low, software performance will be affected due to the rapid recording of data. If it is set too high, the plot will appear artificially jagged.

#### 3.3.13.6 Save Setup

Ensures that any changes are written immediately to the proper INI files.

#### 3.3.13.7 Mechanical\_Setup

This allows the user to set the Rheometer up with optional or custom bobs, Rotors, and springs.

#### 3.3.13.8 Calibrate Each Bob

This allows a separate torque calibration to be used for each bob.

#### 3.3.13.9 Disable Leak Detect

There are three levels of leak detection available. All of these are intended to prevent the system continuing to heat and pump fluid when the system exhibits symptoms of a leak. Any or all of these can be disabled by clicking the LED next to the description. In general, the **Sudden Loss** should not be disabled. The **Pump Integral** and **Pump Cycling** are more sensitive, and will generate some false leak detects. They may be disabled unless the Rheometer is in a particularly leak sensitive environment.

#### 3.3.13.10 Reset Mechanical Zero

This is used on initial setup and after a mechanical change to the Rheometer. It should only be used when the cell is assembled properly for that purpose.

#### 3.3.13.11 Default “From” Email

This is the email address that any email updates sent from the software will appear to be from. It does not need to be a real email address.

#### 3.3.13.12 XLSTemplatePath

This allows the system to be set up with a custom location for report templates. This could be a network location, which would allow a master template to be kept in a single location and used on several Rheometers.

#### 3.3.13.13 DataStoragePath

This allows the system to be set up with a custom location for test reports. This could be a network location, which would allow all of the reports from several Rheometers to be stored in one place.

#### 3.3.13.14 Minimum “Start” Test Pressure

This value is used to prevent boiling water in the system due to insufficient pressure. If **Enforce Minimum Pressure** is checked, the system will try to prevent boiling until this pressure value is reached.

#### 3.3.13.15 Enforce Minimum Pressure

If this LED is lit, the system will use the pressure in Minimum “Start” Test Pressure as a minimum pressure to avoid boiling water in the system.

#### 3.3.13.16 Custom Report Configuration

Clicking this button allows the custom report generation to be customized to support a wide variety of test formats.

### 3.3.14 Manual Test Profile Creation

#### 3.3.14.1 How a Test Profile Works

A test file is a series of steps that are executed in sequence. The program will stay on the current step until all of the “Wait” criteria have been satisfied. The wait criteria are:

- Time (MINIMUM time for the step)
- Speed (at the set point  $\pm$  the Tolerance)
- Temperature (at the set point  $\pm$  the Tolerance)
- Pressure (at the set point  $\pm$  the Tolerance)
- Viscosity (at the set point  $\pm$  the Tolerance)

The LEDs above Time, Temperature, Pressure, and Viscosity indicate whether or not the system is waiting on that parameter for completion of the current step.

In order for a step to be complete, the Time must be expired AND the Speed, Temperature, Pressure, AND Viscosity must be at the specified set point (all at the same time).

If a tolerance is set to zero, then the program will not wait for that parameter.

If a step has a **Repeat Count**, then all of the PRECEDING SEQUENTIAL steps that have the same **Cycle Label** will be repeated until the repeat count is reached. The steps will execute at least once even if the **Repeat Count** is zero.

If and only if **Report Data?** is set to one, the data collected on this step will be included in the preformatted

reports (Newtonian or Power Law). All data is included in the Raw Data output.

The data collection interval in seconds may be set for each step. Any value at or below 0.1 seconds will result in data collection about every 0.1 seconds. If you do not wish to collect any data, set this value higher than the length of the step. Note that the data collection rate does not determine the screen update rate.

Note that any test step may be edited while the test is in progress. Changes take effect the next time a step is executed. That means that a change to the current step or a previous step will only take effect if the step is repeated (using the **Repeat Count**) or if the test is run again.

#### 3.3.14.2 Creating and Editing a Test Profile

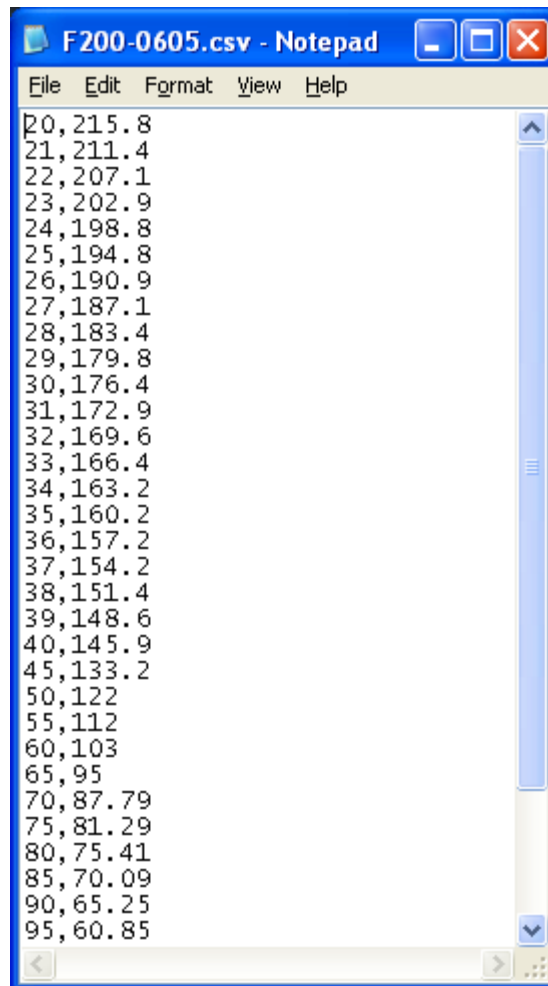
Several example profiles are installed with the software, and these may be copied and edited to produce new profiles. Microsoft Excel is a good tool for editing these files, but they may also be edited in many other programs (such as Windows Notepad). Note that if you edit these files, you will see additional columns that are not displayed in the program. The four columns on the far right are for saving the system units under which the test is to be run (English or metric). Only the values in the first data line affect units, and all other information in the first data line is ignored.

Alternatively, the program can be used to create a test profile. This may be done by starting from a blank Test Profile, or by loading an existing Test Profile and modifying it. If steps need to be added (to a blank profile or after the end of an existing profile), simply click in one of the columns you wish to edit on the first unused (grayed out) line below the current test steps. After making the edit you will notice that the line is no longer gray. You may insert a step between two existing steps by right clicking on the step of interest and choosing **Insert Element Before** from the menu.

#### 3.3.14.3 Appendix 1: Calibration Fluid File Format

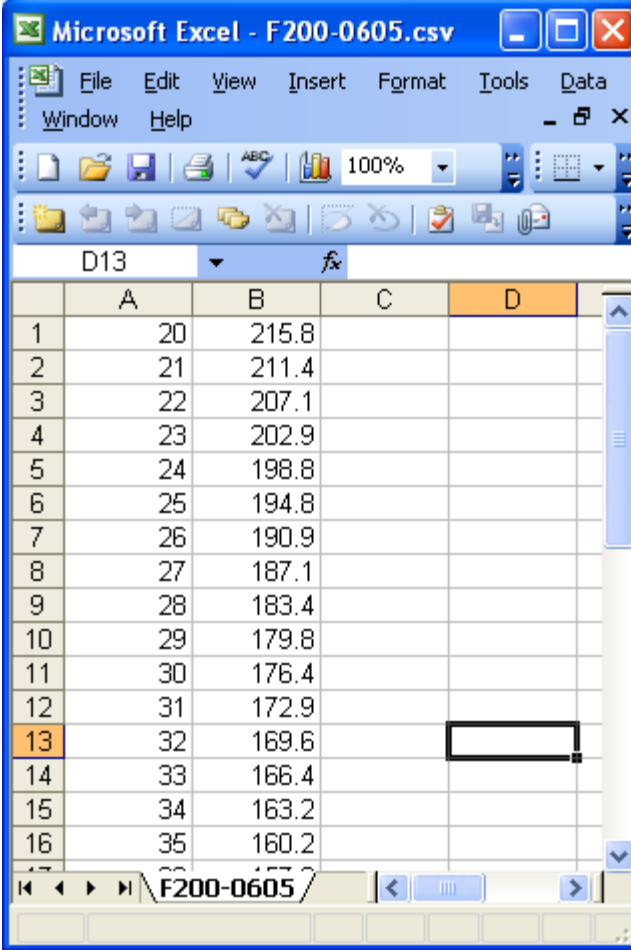
The calibration file should be a text file with a **.CSV** extension. It may be created and edited in any text editor or spreadsheet. There must be no header and no column labels. The file consists of a number of lines each containing a temperature in degrees C, a comma (,), and a

viscosity in centipoise. If such a file were opened (or created) with windows Notepad, it would appear as follows:



**Figure 3-9** Calibration file in Notepad

If such a file were opened (or created) with Microsoft Excel, it would appear as follows:



The screenshot shows a Microsoft Excel window titled "Microsoft Excel - F200-0605.csv". The spreadsheet has columns labeled A, B, and C, and rows numbered 1 through 16. The data in the spreadsheet is as follows:

	A	B	C	D
1	20	215.8		
2	21	211.4		
3	22	207.1		
4	23	202.9		
5	24	198.8		
6	25	194.8		
7	26	190.9		
8	27	187.1		
9	28	183.4		
10	29	179.8		
11	30	176.4		
12	31	172.9		
13	32	169.6		
14	33	166.4		
15	34	163.2		
16	35	160.2		

Figure 3-10 Calibration file in Excel



It is recommended that only 200 cP calibration fluid be used to insure the maximum shear stress can be displayed. Lower viscosity standards will limit the maximum shear stress value that will be displayed

## 4 Installation

### 4.1 Main Instrument

#### 4.1.1 Tools and Parts

Before starting, the following should be available:

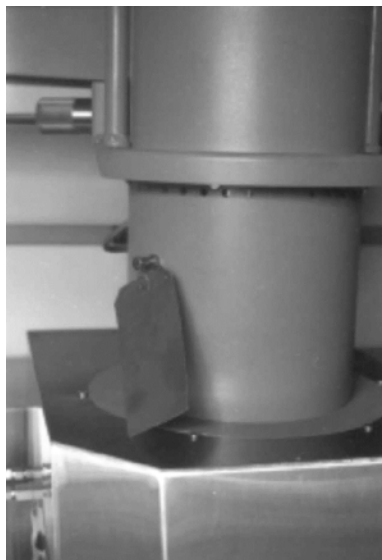
- Adjustable wrench with maximum opening of about 3/4 inch (19 mm)
- Three other people to help move the instrument
- Hose of 1/4 inch internal diameter to reach from a cold tap water supply and the drain to the back right bottom of the unit. It must be capable of withstanding the pressure of the tap water supply for extended periods as well as hot water and steam.
- Four quick connect to pipe adapters are supplied for 1/4 inch tubing. If other types of piping or tubing are used, the user must supply all fittings to adapt from 1/4 female NPT to whatever is used.
- 230 VAC 50 or 60 Hz 20A single-phase electrical power outlet. If required, an electrical cord adapter to connect the electrical power cord supplied to the available outlet.
- Compressed air supply providing a minimum of 2.5 CFM at 80–100 psi. Suitable hose and fittings to adapt to female NPT and connect the air supply to the back right center of the unit.

#### 4.1.2 Procedure

The following step-by-step procedure will help to ensure that your iX77 Rheometer will work properly on startup:



- 4.1.2.1 Select a location for the system which meets local safety requirements. This rheometer should be located near a source of tap water and a drain. The bench surface should be higher than the drain. The bench should be relatively low, or provisions for a step stool must be made. A bench about 21 inches (53.4 cm) high is good. The bench should be stiff and adequate to support 400 lbs (181.4 Kg). Lateral stiffness helps to prevent excessive vibrations due to slight imbalance of the rotating drive components. Minimum bench surface is 24 inches depth x 45 inches width (61 cm x 114 cm) with a recommended size of 30 inches depth x 51 inches width (76 cm x 130 cm), not including air supply, water supply, nor drain fitting protrusions. Additional bench space is required to securely mount the cell preparation fixture.
- 4.1.2.2 Carefully set the unit into position on the bench. It is heavy, so obtain help to move it and use caution.
- 4.1.2.3 Confirm that the proper plug and 230 VAC plug is available with at least a 20 amp rating.
- 4.1.2.4 Remove the three tagged bolts in the side of the safety shield. They are at 120 degree intervals around the shield, with one in the back and one on each side of the front; about 2 inches (5 cm) below the row of vent holes. These bolts lock the rotating parts of the drive during shipment. Accidental over tightening of the bolts could result in damage to the drive.



**Figure 4-1 Shipping bolts with tags**

- 4.1.2.5 Attach the tap water supply to “H2O IN” located on the back of the main unit. Only one wrench is needed to install the fittings because of the specially designed back up plate mounted on the unit. Use the supplied quick-connect adapters if 1/4 inch tubing is used.
- 4.1.2.6 Attach the drain line to the “H2O DRAIN”. Anchor the drain end of the hose so that it cannot jump around when the water spurts out of it on cool down. The drain water will initially be hot, and some steam will also come out of the drain hose. Make sure the hose is not in a position that will allow the hot drain water to splash on anyone.
- 4.1.2.7 An external chiller system may be connected to the “CHILL IN” and “CHILL OUT” ports. The Chiller input pressure cannot exceed a 10 psig differential or leaks will occur around the outer cell O-ring. The Chiller assemblies supplied by FANN (“204160” 120V/60Hz and “381464” 230V/50 Hz) have a built-in gauge and bypass valve to limit the input of pressure. The test cell must be in place when the Chiller is operating. If a chiller is not used, the chiller port may be left open. Water and air will be used as the coolant.

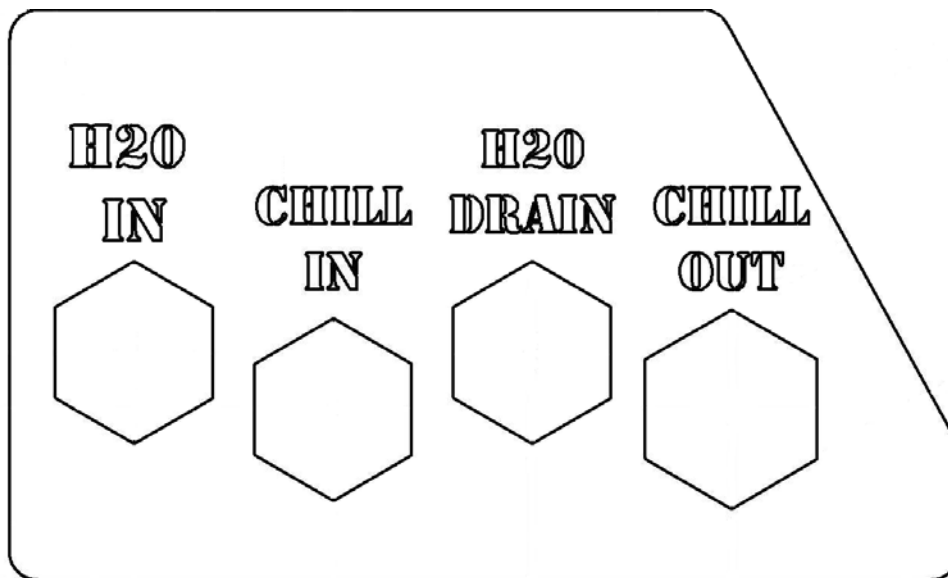


Figure 4-2 Supply and drain connections

## 4.2 Test Cell Preparation Stand

The test cell Preparation Stand supports and protects the test cell and should be used to hold the test cell anytime it is removed from the Hot Well of the Rheometer. Four holes are provided to securely mount the test cell Preparation Stand to any sturdy, convenient surface adjacent to the unit, and all four holes should be used. Ideally, the test cell Preparation Stand would be mounted on the same bench as the Rheometer and just to the left of the instrument.



---

This completes the minimum installation requirements. It is suggested all procedures contained in this manual be reviewed before attempting to calibrate and run a test.

---

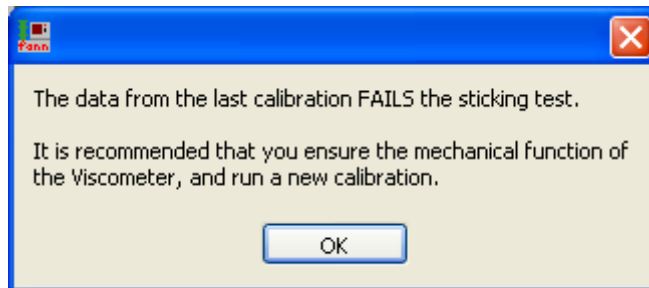
## 5 Operation

### 5.1 Software

#### 5.1.1 Starting the Software

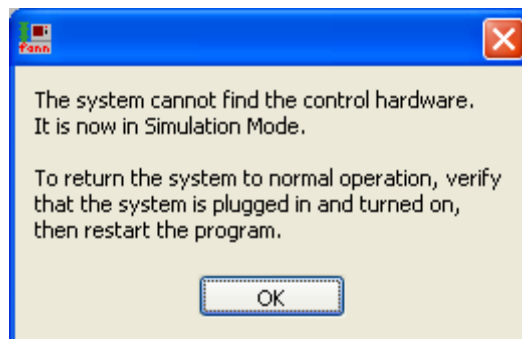
5.1.1.1 Start the software from the desktop icon if it is not already running. Wait until the software is fully loaded (up to 2 minutes).

5.1.1.2 If the software does not find a conforming calibration, the following dialog will be displayed on startup:



**Figure 5-1 Calibration failure dialog**

5.1.1.3 If error messages appear upon startup, it is likely that the software was unable to find the data acquisition and control hardware. If the error messages are cleared but the system still cannot find the necessary hardware, it will display a dialog to inform the user it is entering simulation mode.



**Figure 5-2 Simulation Mode dialog**

5.1.1.4 When the system detects that it is pressurized on software startup, it will use the detected pressure as a manual pressure set point. When the operator has ensured that releasing pressure will not cause harm, the pressure may be set to zero and the pressure will be released.

5.1.1.5 The temperature is always set to zero on startup; no heating will occur until a set point has been given.

5.1.1.6 If the chiller is set up to do so, it may turn on at startup.

5.1.2 Calibrating Pressure

5.1.2.1 Prepare the iX77 Rheometer by filling the cell with a suitable pressurization fluid (it is not necessary to include the bob, rotor, etc. in this assembly). Place the closed cell assembly into the heater well and make sure that all of the pressure connections are made properly.

5.1.2.2 Click the **Calibrate Pressure** button.

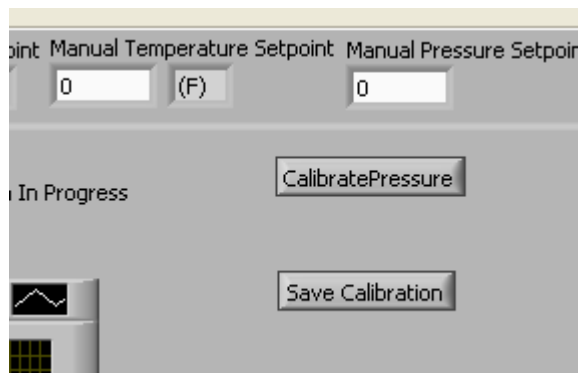


Figure 5-3 Click Calibrate Pressure

5.1.2.3 A dialog will appear to guide you through the pressure calibration.

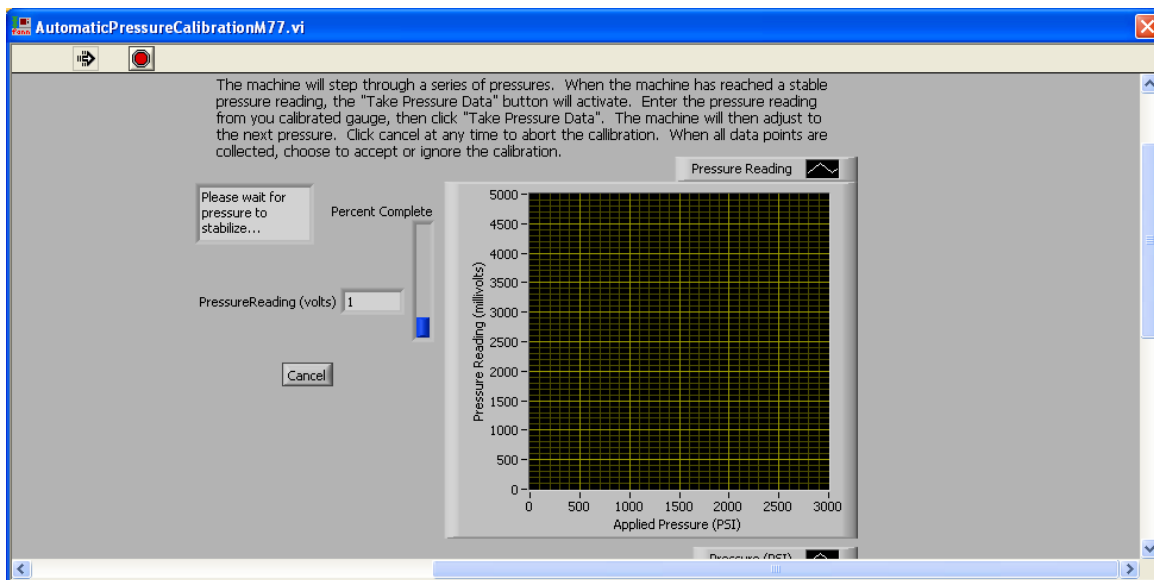


Figure 5-4 Pressure calibration dialog

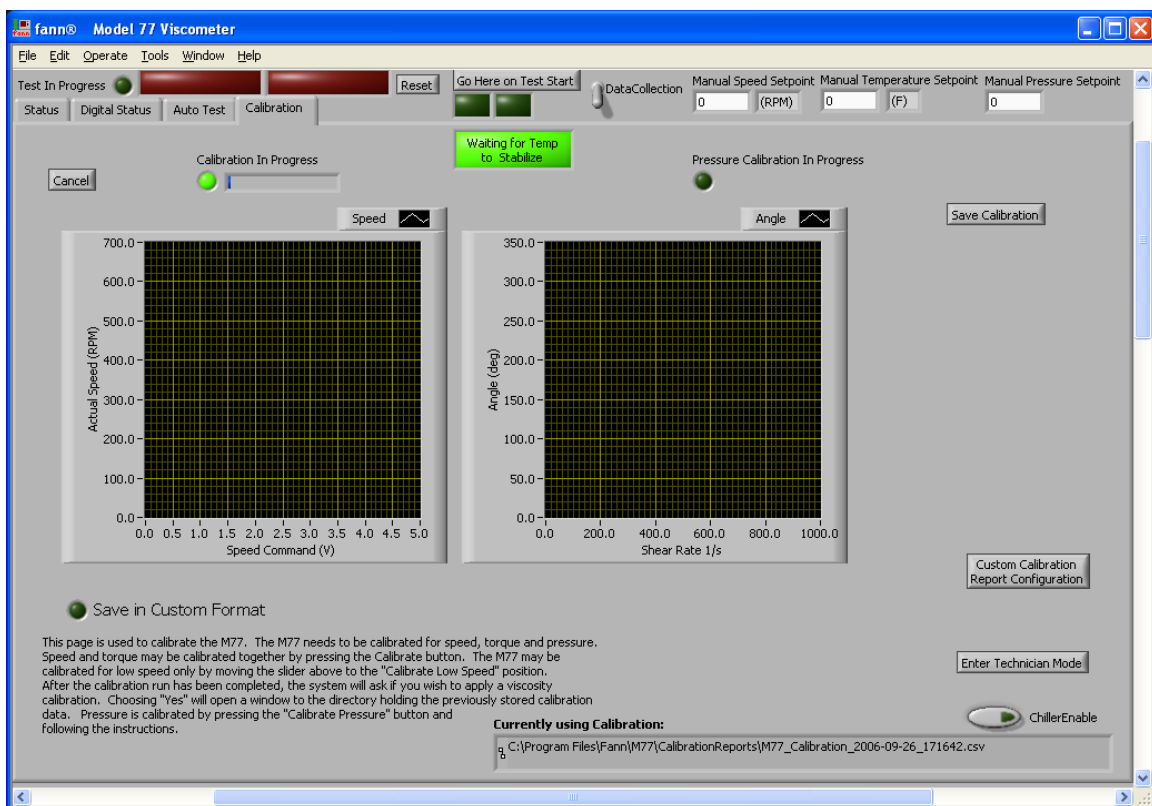
### 5.1.3 Calibrating Torque and Speed

5.1.3.1 Prepare the iX77 Rheometer with a sample of calibration fluid (refer to 5.5 *Calibration*). If the data file for the calibration fluid does not exist, it will need to be created (refer to 3.3.14.3 *Appendix 1: Calibration Fluid File Format*).

5.1.3.2 Click on the **Calibration** tab if it is not already showing.

5.1.3.3 Click the **Calibrate** button.

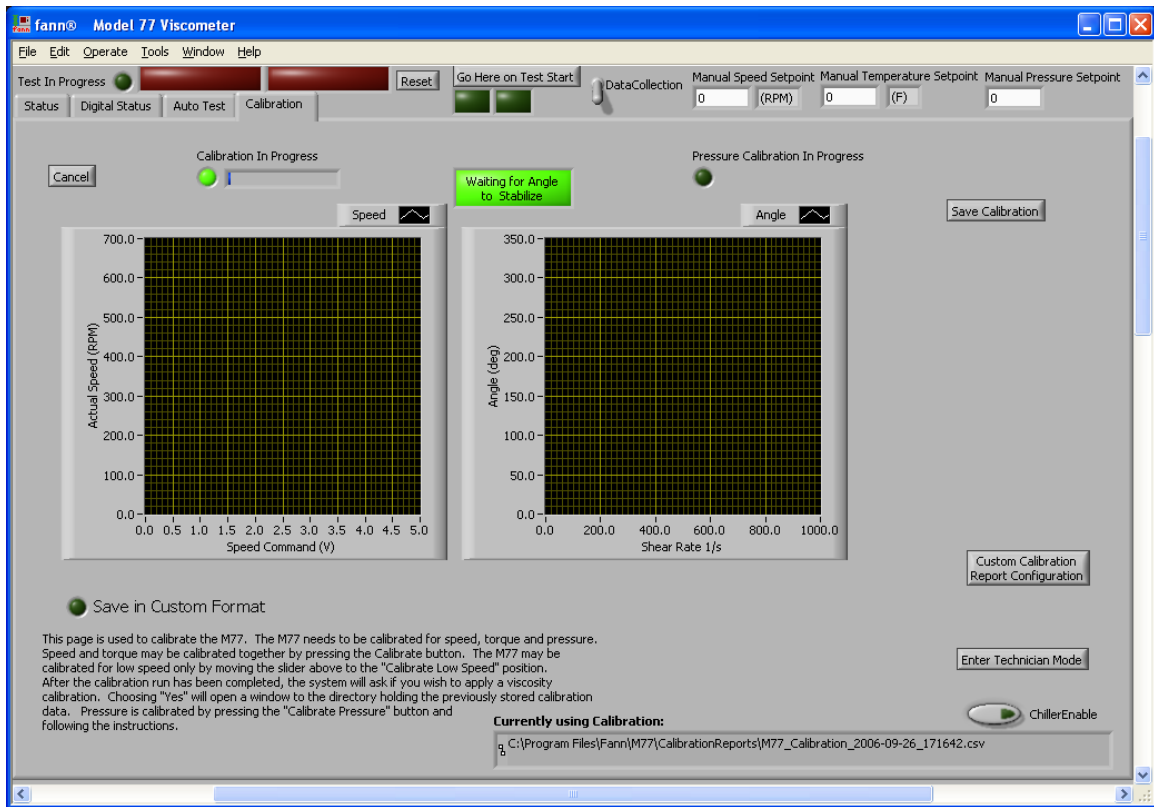
5.1.3.4 The software will begin stirring to ensure that the temperature has equalized.



**Figure 5-5** Waiting for temperature to stabilize

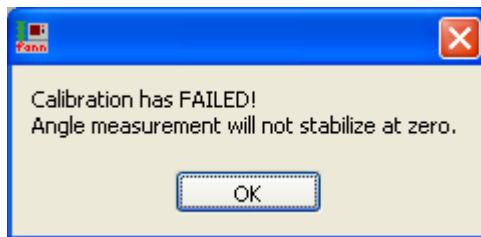
5.1.3.5 This step will continue until the temperature has equalized or the cancel button is pressed.

5.1.3.6 After the temperature has equalized, the software will wait for the angle measurement to return to zero.



**Figure 5-6** Waiting for the angle measurement to return to zero

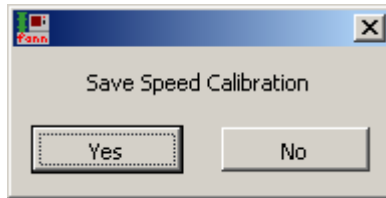
5.1.3.7 If the angle does not stabilize near zero, the calibration fails and is automatically canceled. This is usually the result of a mechanical failure or an assembly issue. These issues must be resolved prior to calibrating.



**Figure 5-7** Calibration failure dialog

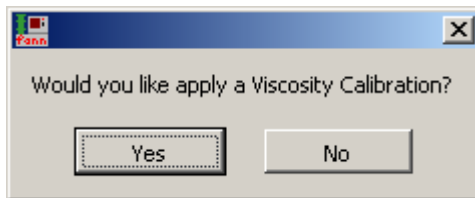
5.1.3.8 Once the angle has stabilized, the software will begin slowly ramping the speed of the rotor through a series of values (these values may be adjusted by the installer or a qualified technician). As it ramps through those values, it is building the lookup table for later use (assuming that the calibration is accepted).

- 5.1.3.9 When the software has finished stepping through the values, it will ask if you wish to keep the speed calibration.



**Figure 5-8 Save Speed Calibration dialog**

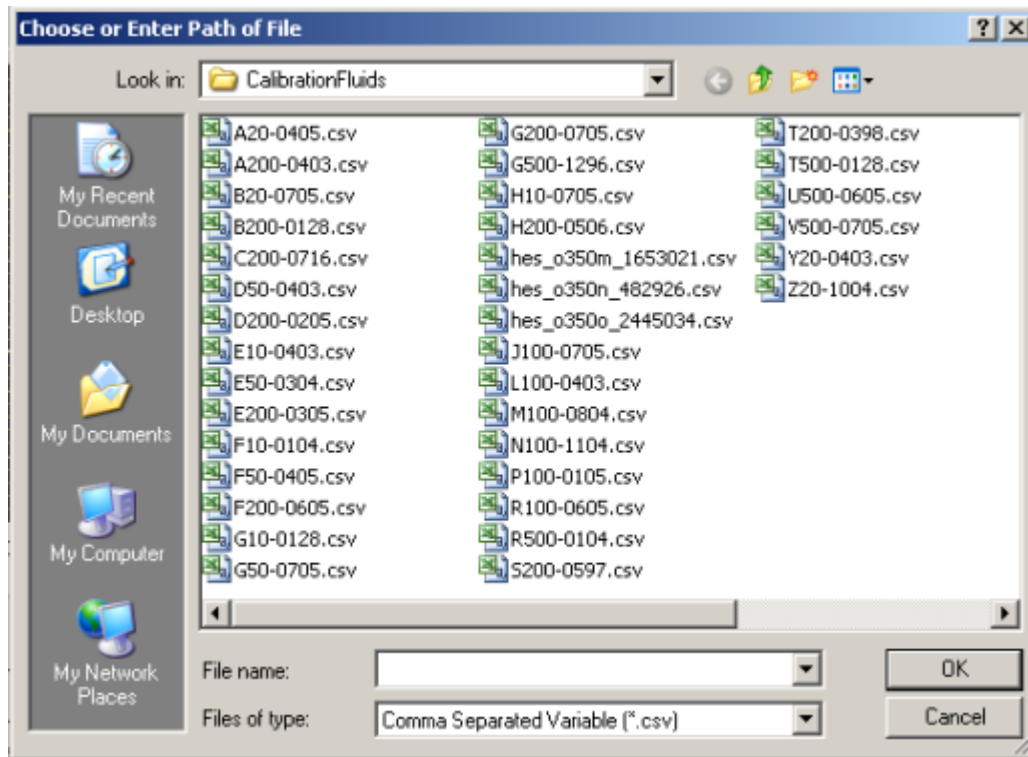
- 5.1.3.10 If you accept the speed calibration, you will be asked if you wish to apply a viscosity calibration.



**Figure 5-9 Viscosity Calibration dialog**

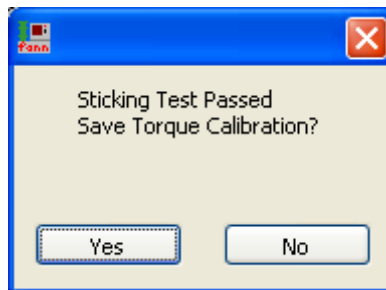
- 5.1.3.11 If you choose **Yes** (required in order to calibrate the Rheometer), you will be asked to choose a file containing the calibration data for the calibration fluid. Choose the fluid from the list displayed or browse to select the correct file.





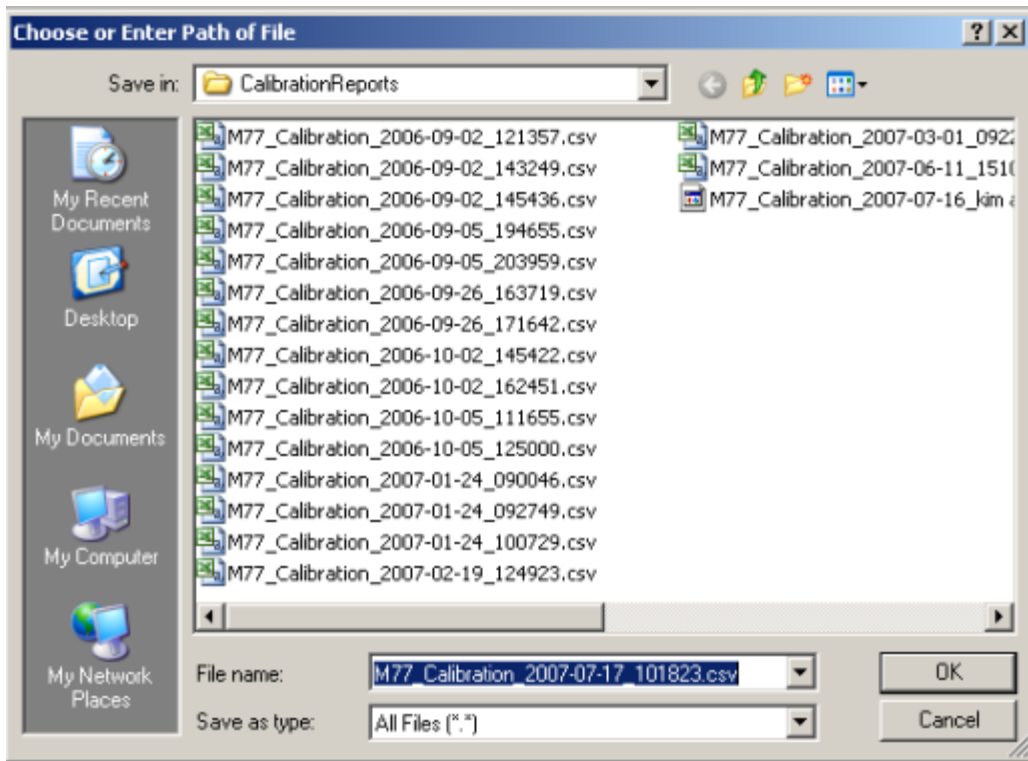
**Figure 5-10 Choose calibration data file**

5.1.3.12 Once a fluid is chosen, the software will compute a calibration and check for hysteresis in the system. If the calibration is acceptable, you will see a dialog that asks if you wish to save the calibration. (The number may be ignored.)



**Figure 5-11 Save Torque Calibration dialog**

5.1.3.13 If you choose **Yes**, a dialog will appear that allows you to choose where to save the calibration file and what to call it. It is recommended that you accept the default that is offered.

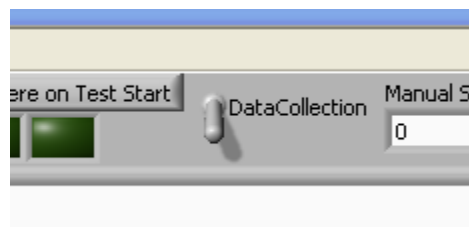


**Figure 5-12 Choose the path to save the calibration file**

5.1.3.14 The file path will appear on the **Calibration** tab until the next time a calibration is performed.

5.1.4 Running a Manual Test

5.1.4.1 Click the **Data Collection** switch on the front panel to begin recording data (one sample per second).



**Figure 5-13 Data Collection switch**

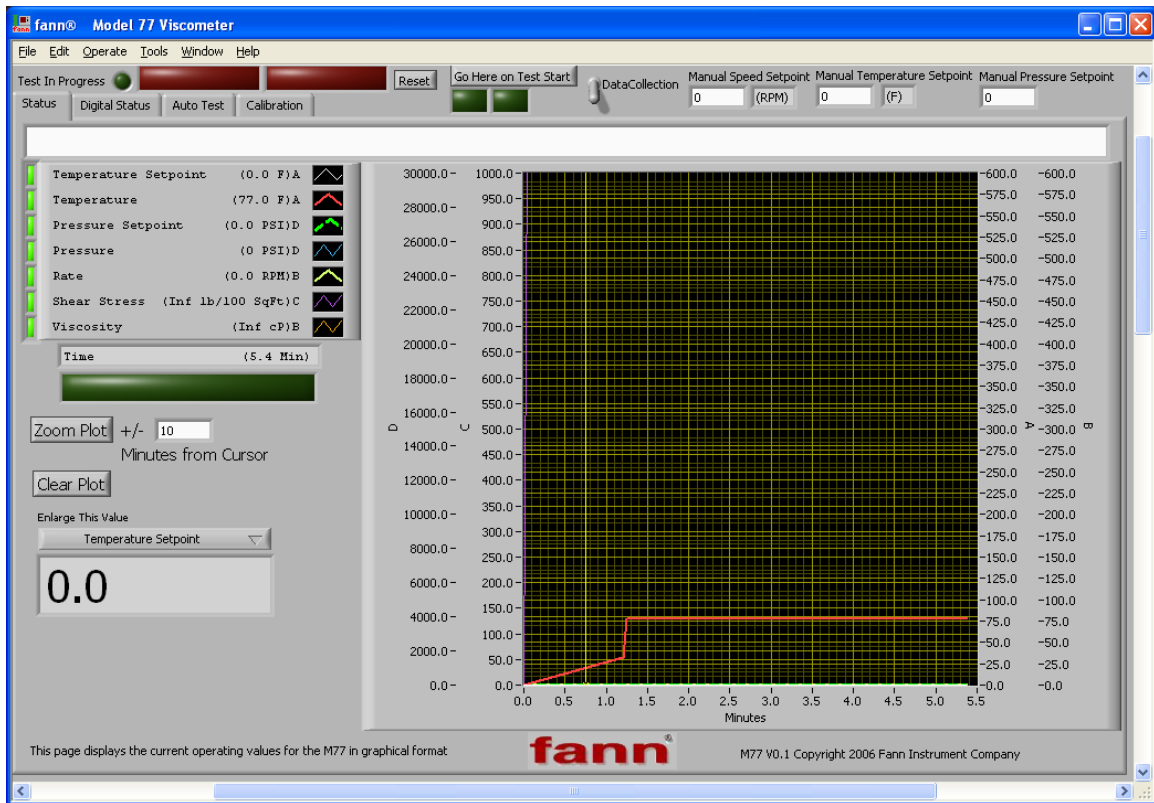
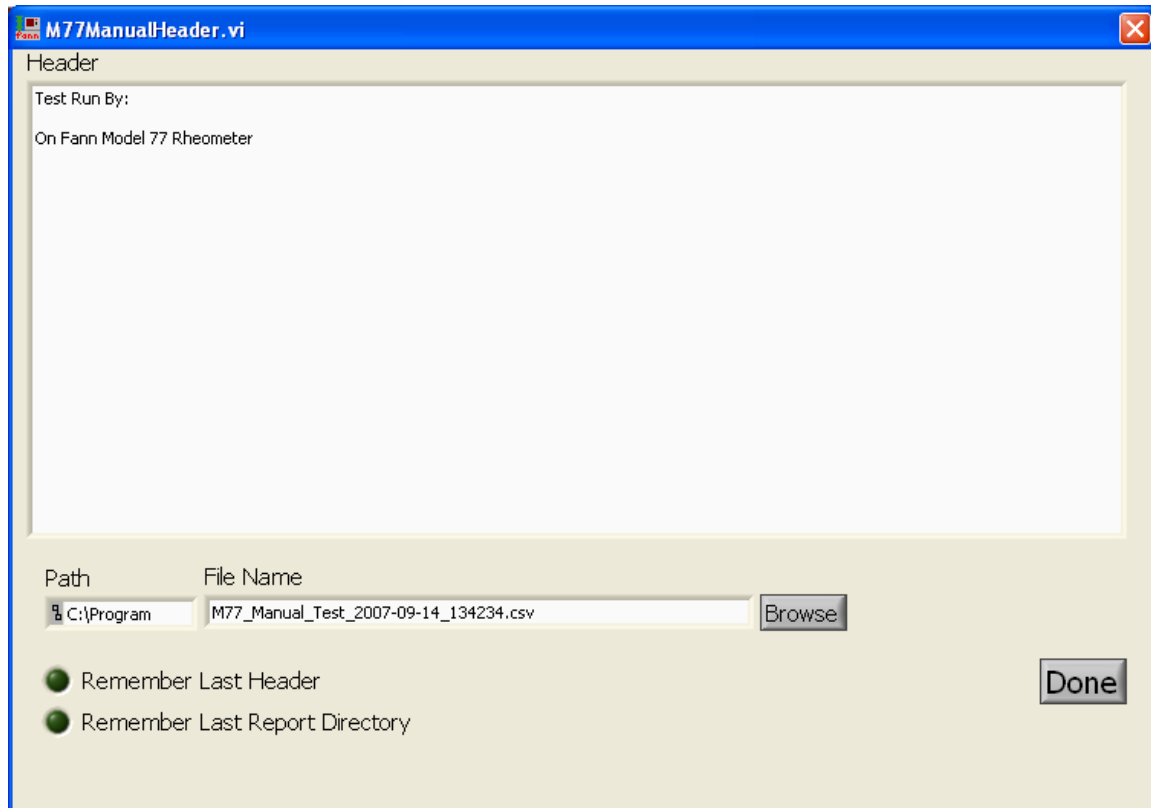


Figure 5-14 Current operating values

5.1.4.2 Fill out the desired information in the dialog and click **Done**.



**Figure 5-15** Fill out information and click Done

5.1.4.3 Enter set points for rotor speed, temperature, and pressure. Note that the system will simply try to achieve these set points as rapidly as possible (the system will not try to exceed its programmed maximum temperature and pressure regardless of the set points).

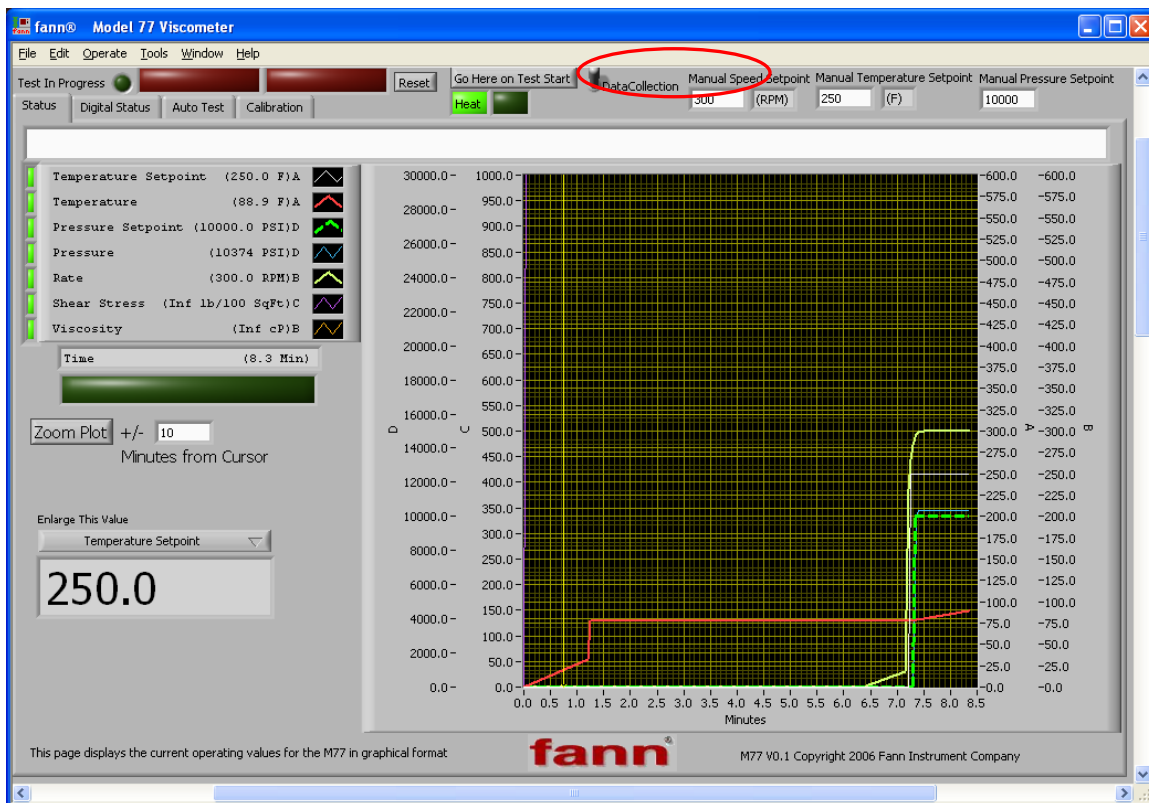


Figure 5-16 Enter set points

5.1.4.4 Clicking the **Data Collection** switch again stops the data recording.

5.1.4.5 In order to stop / cool / depressurize the system, the operator must set the manual set points to zero.

5.1.5 Running an Automatic test

The iX77 Rheometer is capable of performing tests that include (within the physical capability of the machine) arbitrary profiles of temperature, pressure, and rotor speed. The test profile also controls when and at what rate data is collected. This system of describing and executing tests is very powerful, but programming

and testing a test sequence directly is somewhat arcane. To address this issue, a test sequence generator has been included in the software. This provision drastically simplifies test sequence entry for the vast majority of the anticipated user base. This is the method that will be described here.

To generate an automatic test sequence:

- 5.1.5.1 Prepare the iX77 Rheometer with the sample you wish to test (refer to 5.3.1 Load Sample into Cell)
- 5.1.5.2 Click on the **Auto Test** tab if it is not already showing.
- 5.1.5.3 Click on the **Generate Test Sequence** button.

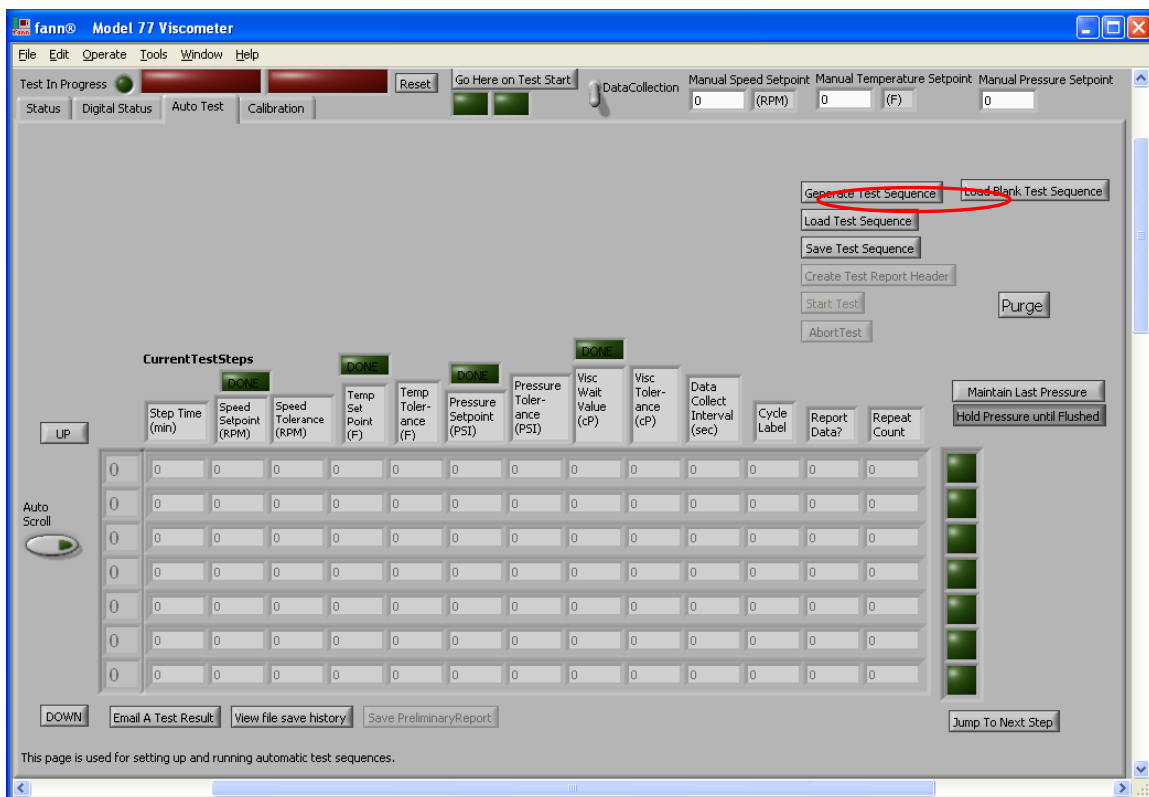


Figure 5-17 Auto Test tab

5.1.5.4 The Test Point entry dialog displays.

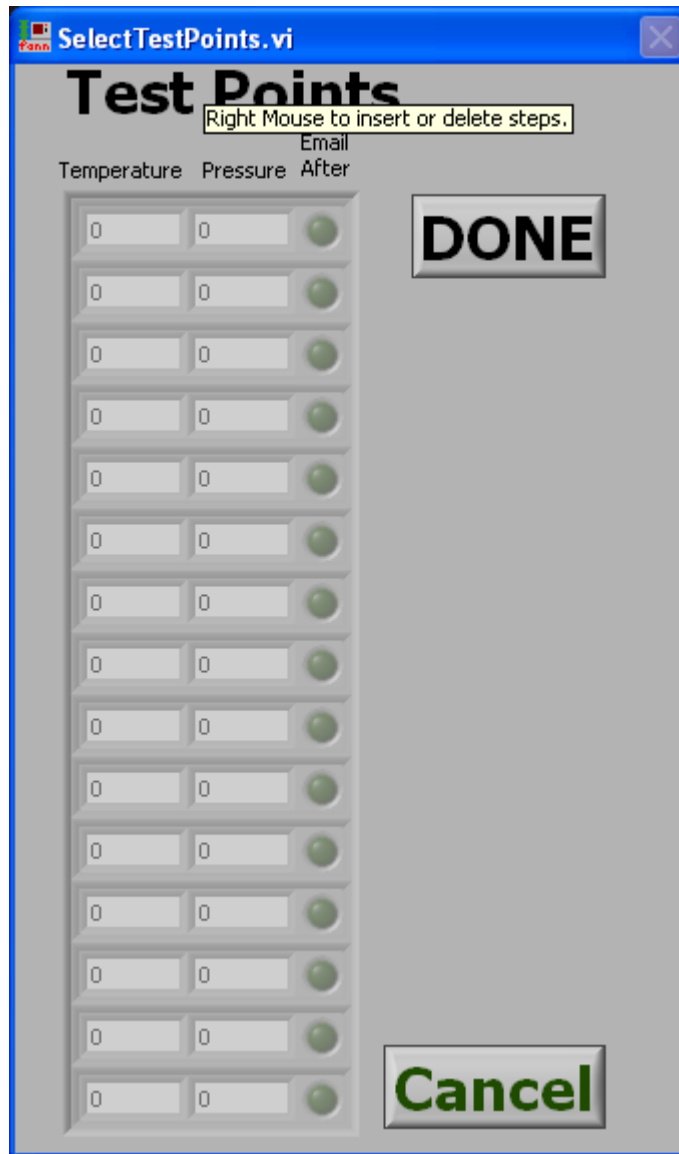


Figure 5-18 Test Points dialog

5.1.5.5 Fill in the temperature and pressure test points required for the test to be run. If desired, the light in the **Email After** column may be clicked. This will send an email with preliminary results after the chosen step is completed. Click **DONE** when finished.

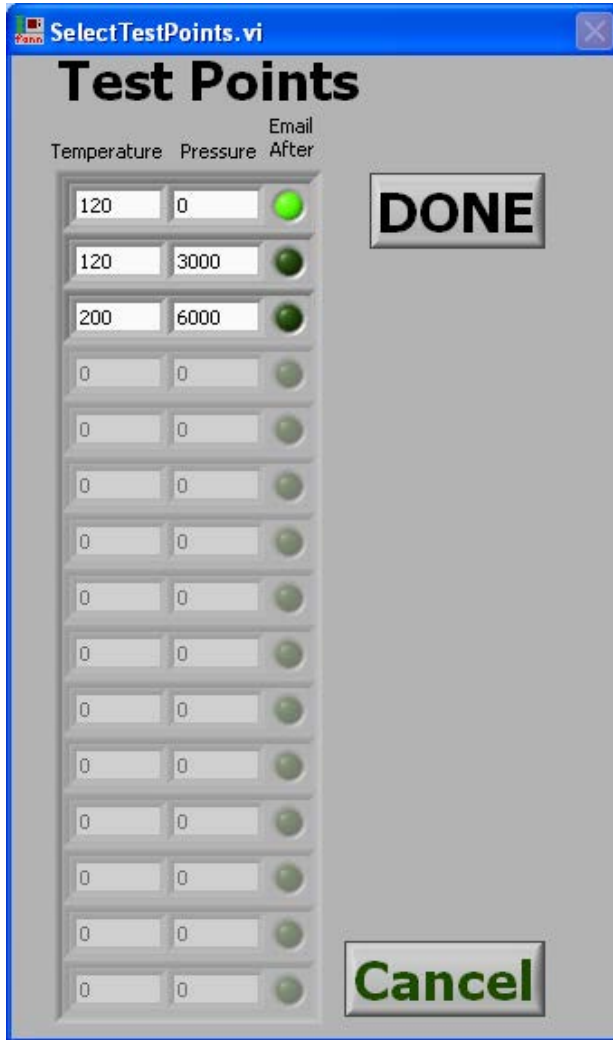


Figure 5-19 Fill in temperature and pressure test points



5.1.5.6 The automatically generated test sequence will be displayed.

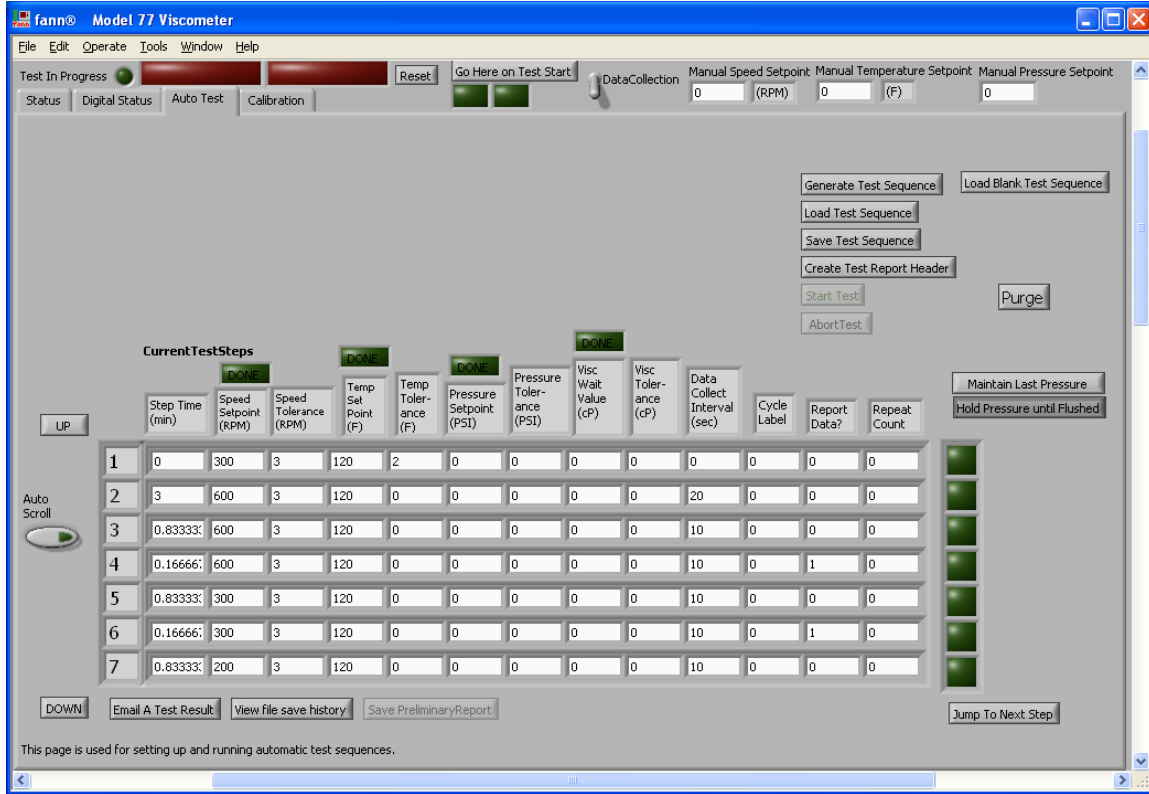


Figure 5-20 Automatic test sequence

5.1.5.7 This test profile can be saved to a file for later use by clicking **Save Test Sequence** and retrieved by clicking **Load Test Sequence**.

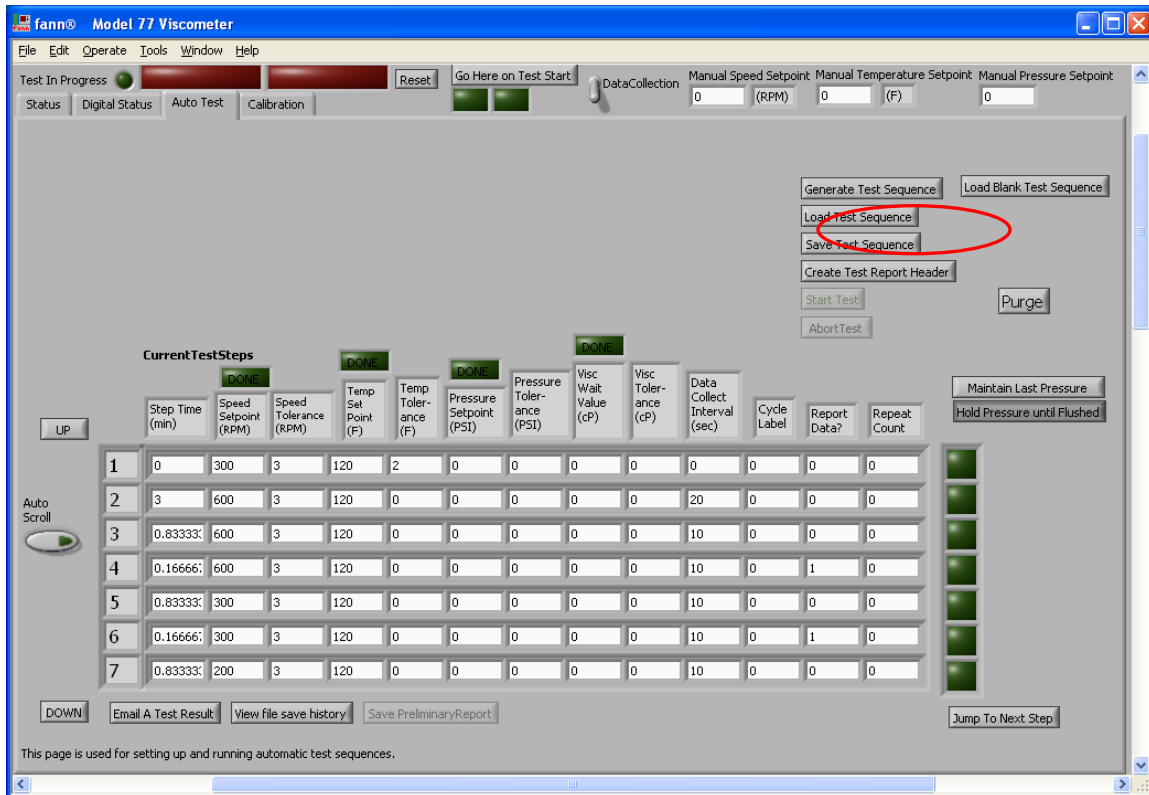


Figure 5-21 Save and retrieve files

5.1.5.8 To begin testing the fluid, you must create a test report header. Click **Create Test Report Header**.

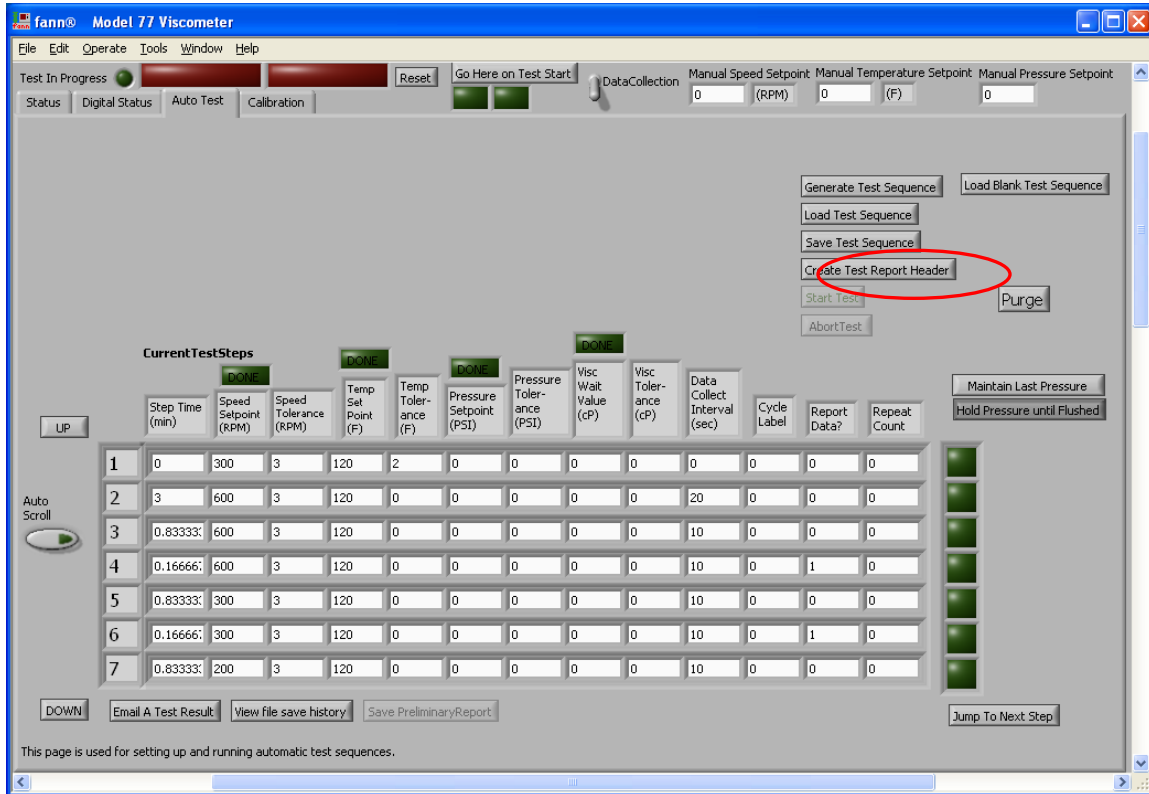
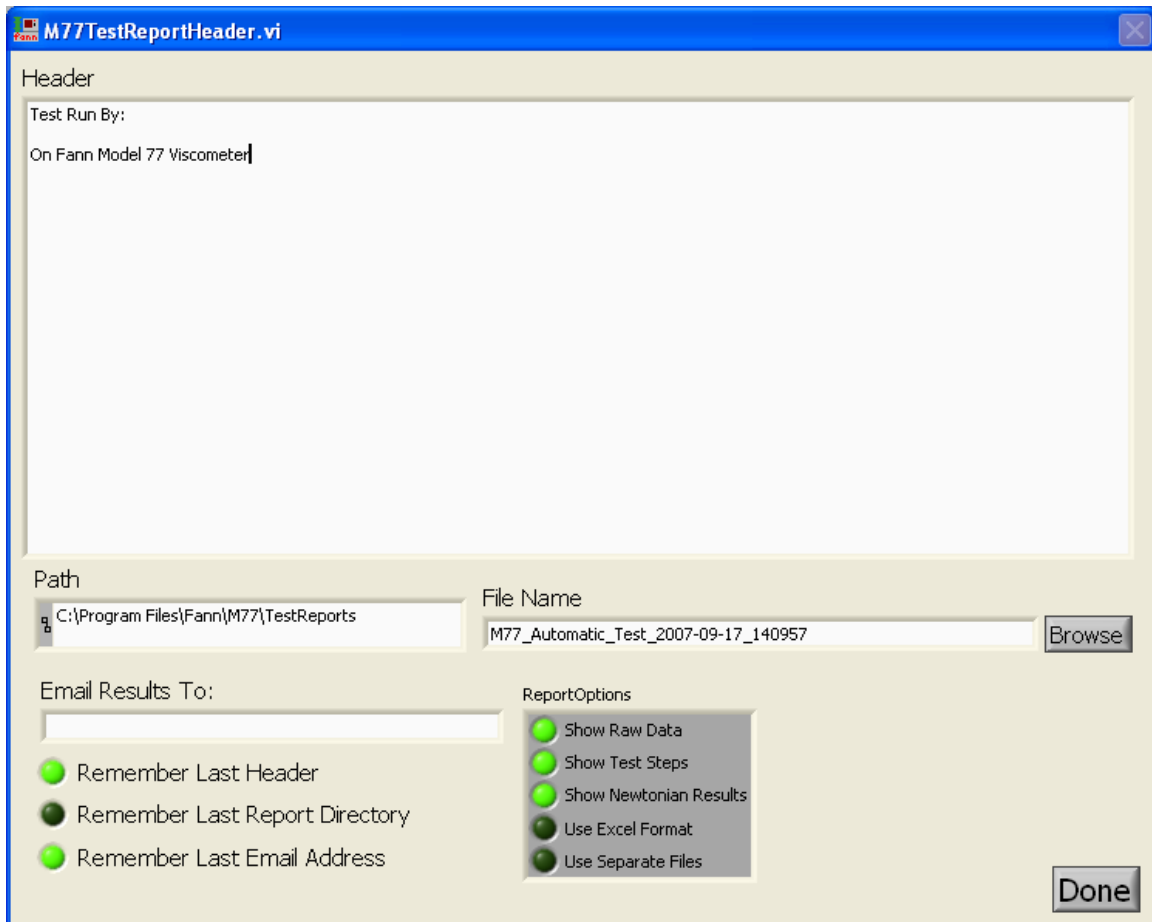


Figure 5-22 Create test report header

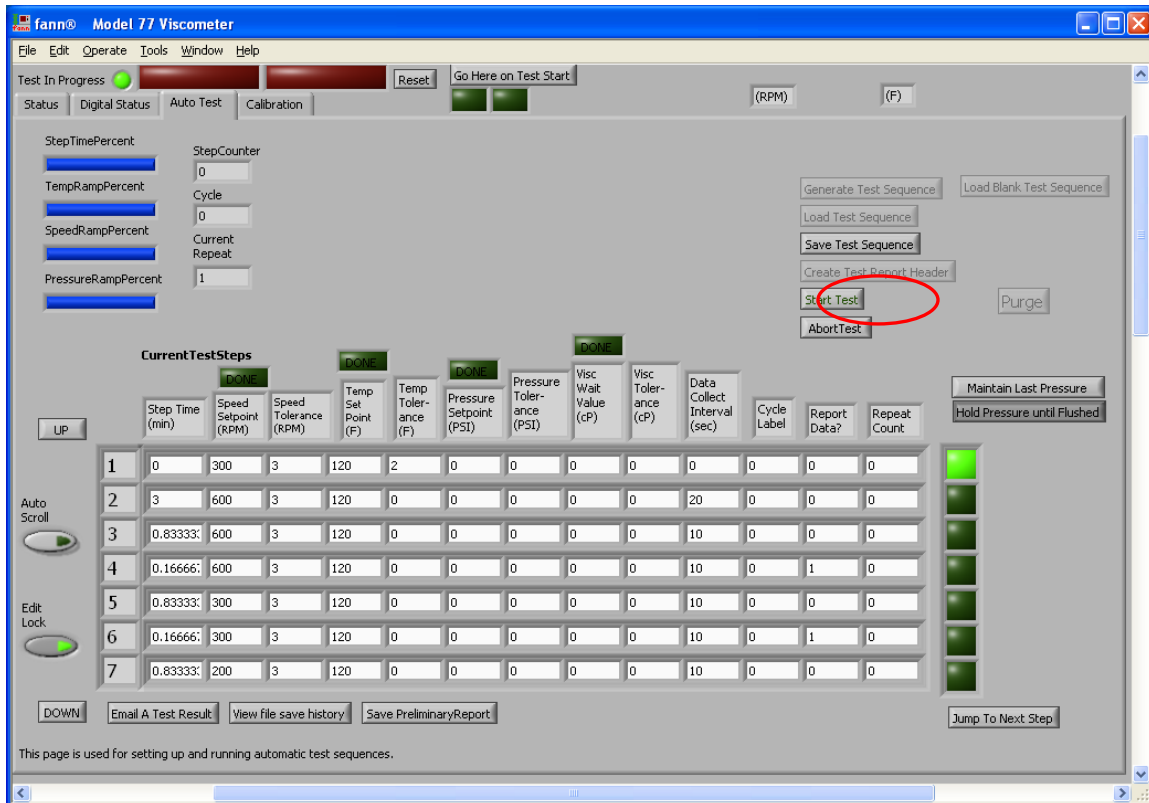
## 5.1.5.9 The dialog displays.



**Figure 5-23 Test Report Header dialog**

5.1.5.10 Edit the header and file name as desired and adjust any options as needed. Click **Done** when finished.

5.1.5.11 The **Start Test** button is now enabled (unless the Angle is too far away from zero, indicating a mechanical issue). Click the **Start Test** button to begin executing the test sequence.



**Figure 5-24 Start the test**

5.1.5.12 Once the test is running, the start button will be disabled. By default, the test steps will scroll to keep the active step at the top of the list.

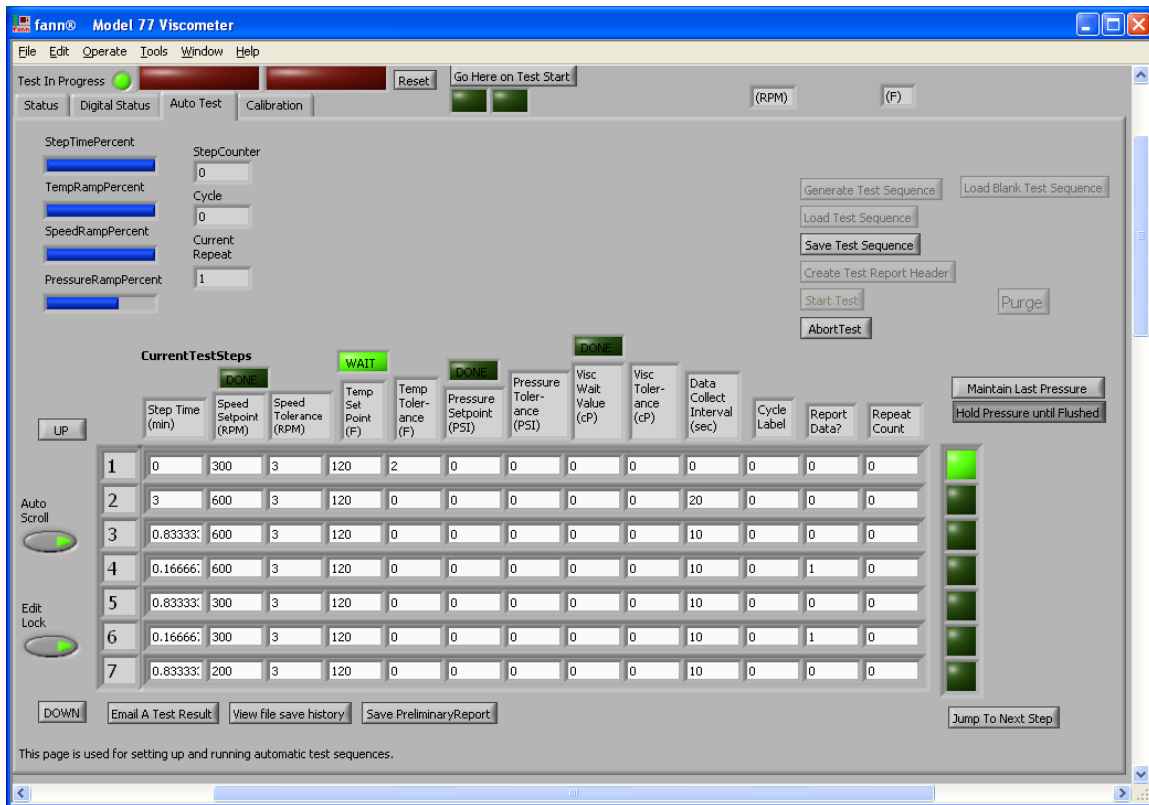


Figure 5-25 Disabled Start button

5.1.5.13 If for some reason you wish to end a step early, you may click **Jump To Next Step**. If you wish to end the test immediately, click **Abort Test**.

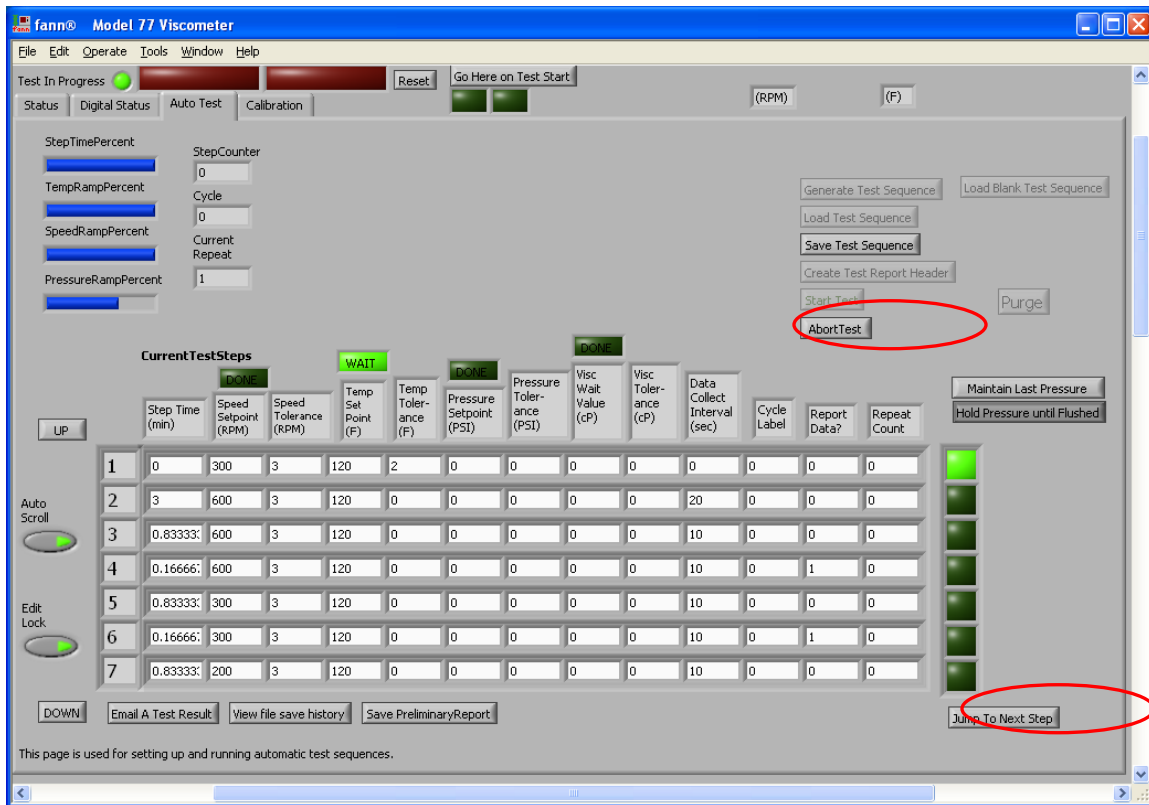
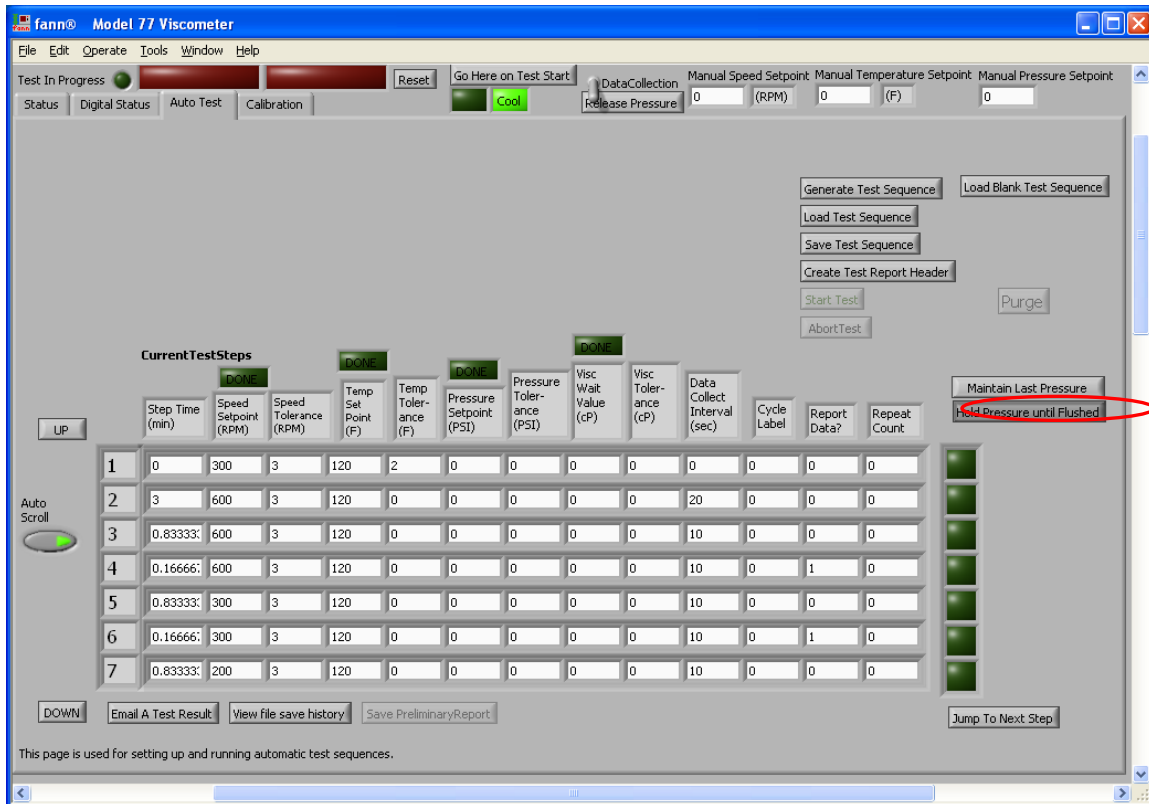


Figure 5-26 Jump To Next Step and Abort Test options

5.1.5.14 When the test ends, the temperature set point will be set to zero. There are three options for controlling pressure at the end of the test:

**Option 1: Hold Pressure until Flushed (DEFAULT)**



**Figure 5-27 Hold Pressure until Flushed**

- Recommended for most tests.
- For practical purposes, this mode does not release any fluid until the operator presses the **Release Pressure** button.
- The pressure is allowed to drop naturally as the temperature falls.



Option 2: Maintain Last Pressure

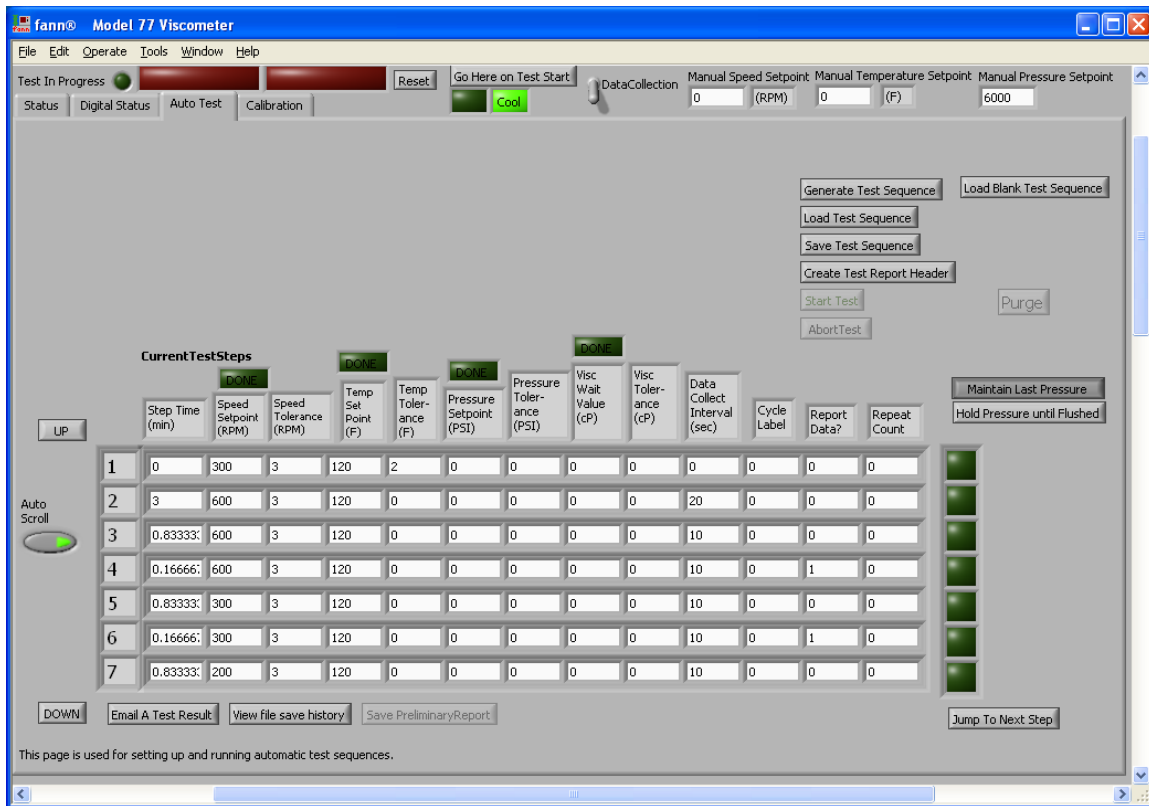
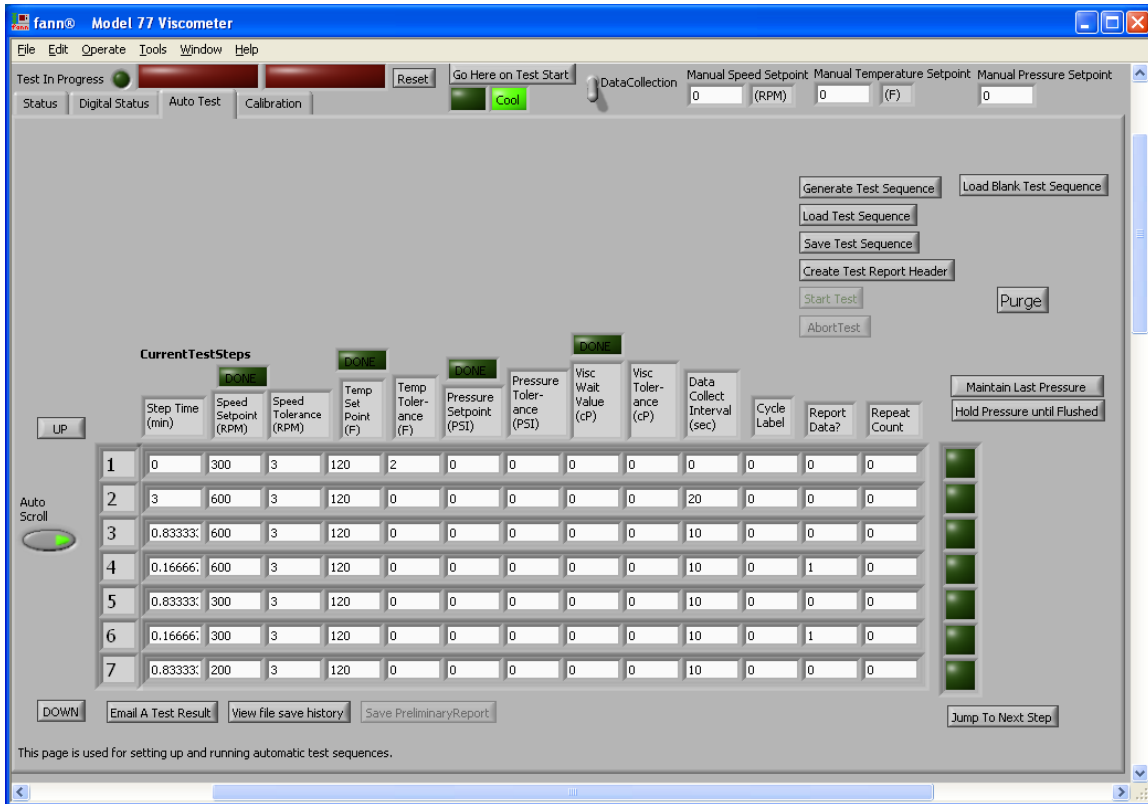


Figure 5-28 Maintain Last Pressure

- For use when a sample needs to stay at the last pressure after the test has ended.
- The pressure set point at the end of the test becomes the manual pressure set point, and the pump is used to maintain it.
- The operator must set the manual pressure set point to zero in order to release pressure on the system.

**Option 3:** Pressure set point is set to zero.



**Figure 5-29 Pressure set point is set to zero**

- Not recommended for most tests.
- For use only when a sudden release of pressure will not harm the system (a sudden release of a hot test fluid, such as a drilling mud, could clog the high-pressure filter).

**5.2 Test Preparation – Mechanical**

**5.2.1 Test Cell Preparation**

It is assumed that the assembled upper and middle sections of the test cell are properly locked in place on the test cell preparation stand.

5.2.1.1 Remove the cap to expose the torsion assembly for inspection. It should be clean.

- 5.2.1.2 The cell, rotor assembly, bob, and bob shaft must be clean and free of anything that might contaminate the sample. It may be necessary to disassemble and clean the coupling (middle) and cap (top) parts of the test cell. Wipe any pressurization fluid or sample from the exposed threads and the bottom of the coupling.
- 5.2.1.3 Screw the cell baffle snugly in the bottom of the coupling. Pass a metal rod through the holes in the baffle to tighten it.



If the cell baffle is not tightened sufficiently, it may unscrew during a test until it touches the top of the bob. It may press down hard enough to damage the bob's vee jewel. If the displayed angle reading stops changing during a test, this is probably the cause.

---

- 5.2.1.4 Apply a light coat of lubricant (P/N 210435), a nonmetallic anti-seize compound, to the threads of the bob shaft, both ends.



Do not overtighten the bob shaft into the bob and limit stop. If this connection is too tight, the assembly could be damaged.

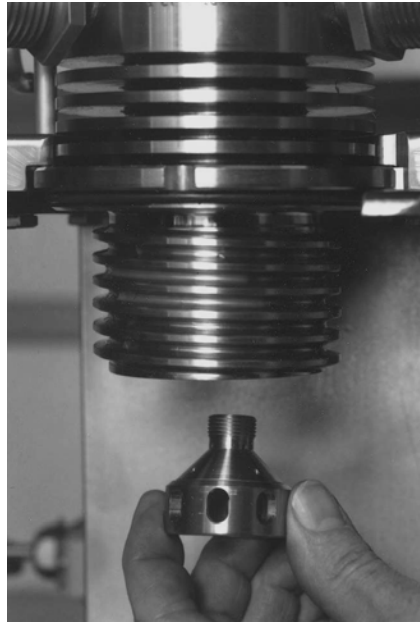
---

- 5.2.1.5 Screw the bob snugly onto the bob shaft, using a round shaft or dowel rod, through the holes in the bob shaft to hold it.
- 5.2.1.6 Hand-tighten the bob shaft assembly into the limit stop.

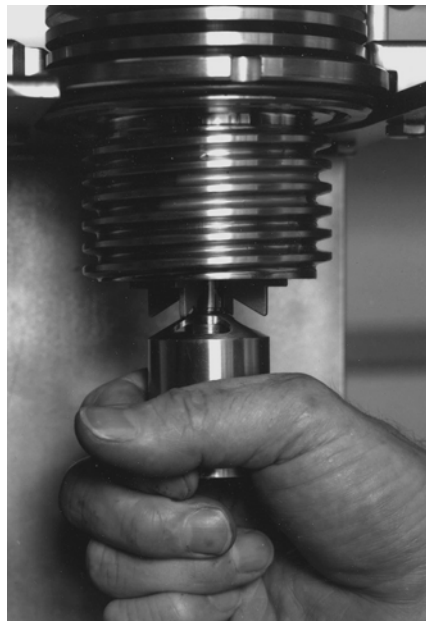


The assembly only requires 8 to 10 in-pounds of torque to tighten it. Do not overtighten.

---



**Figure 5-30** Installing type “S” baffle



**Figure 5-31** Installing bob shaft assembly

- 5.2.1.7 If necessary, replace the pivot bushing, rotor bushing inner race, and the rotor bushing outer race. Use the tools provided and follow the procedures outlined in *5.4.4 Rotor Bushing Replacement*.
- 5.2.1.8 Remove the cell seal O-ring and backup ring if they are installed.



The metal backup rings are easily damaged and must be handled carefully to avoid bending them. Handled very carefully, they can be used many times.

- 5.2.1.9 Place the rotor assembly into the cell, being careful to not hit it against the pivot point. Do not drop it into place as it may damage the rotor bushing. Lower it gently into place and verify that it spins freely.
- 5.2.1.10 Place a new cell seal O-ring into its groove in the cell, just above the rotor. Do not reuse an O-ring seal.
- 5.2.1.11 Place the metal cell backup ring on the O-ring with the flat surface facing up.



**Figure 5-32** Installing rotor in cell



**Figure 5-33 Installing cell**

5.2.1.12 Lubricate the threads of the coupling with a small amount of anti-seize compound to prevent thread galling. Severe galling of the threads could ruin the cell assembly.

#### 5.2.2 Verify Mechanical Zero

The following steps establish the mechanical zero position of an empty complete test cell without the error that may occur with a sample in the cell.



---

Each time the torsion spring module is removed, cleaned, and re-installed, the mechanical zero point may shift. This verification procedure may be skipped if the fluid to be tested has no gelling tendencies and is of relatively low viscosity.

---

5.2.2.1 Place the cell under the coupling on the stand. Lift it up and screw the cell into place until it bottoms out. If resistance is felt before it reaches full make-up, stop and investigate. The torsion assembly may be jammed.

5.2.2.2 Make sure that the torsion assembly is free to rotate by pushing the top magnet with a non-magnetic wire or rod.



**Figure 5-34** Checking for free rotation of the torsion assembly



**Figure 5-35** Placing the test cell into the hot well

- 5.2.2.3 Screw the cap onto the coupling hand-tight.
- 5.2.2.4 Install a well seal O-ring if one is not already in place. Stretch it over the bottom of the cell and roll or slide it up into its groove. These O-rings may be reused until they become hard or unpliable.

- 5.2.2.5 Place grease along the outer edge of the O-ring. This will ensure the O-ring slides smoothly in place and seals against the hot well.
- 5.2.2.6 Remove the locking pin and pull the test cell from the stand.

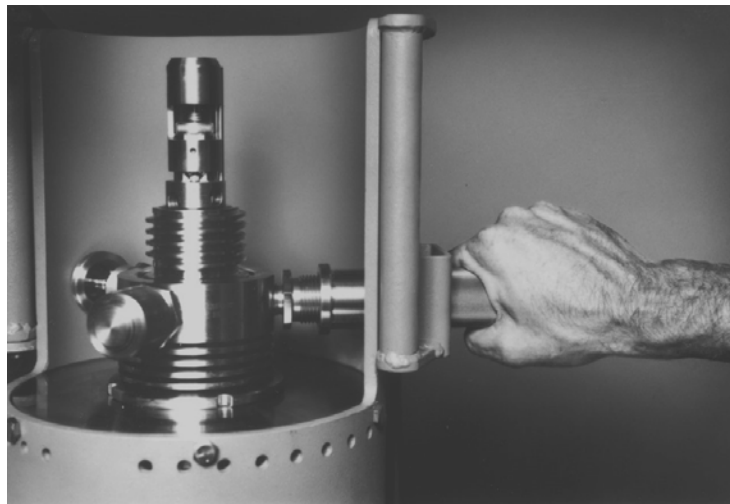


---

The test cell weighs 36 pounds (16.4 kg) and should be handled with two hands.

---

- 5.2.2.7 Lift the test cell from the test stand and lower it into the hot well of the iX77 with the capped sample port toward the front. A step stool may be useful if the bench is too high. Slightly rotate the cell each way in the hot well to make sure the O-ring seals properly.
- 5.2.2.8 Screw the two port connectors fully into place. Hand tight is adequate for good sealing. It may be necessary to rotate the test cell slightly to line it up with the connectors. Do not lift the test cell, or the well seal O-ring may be shifted out of position.



**Figure 5-36** Screwing in the port connector

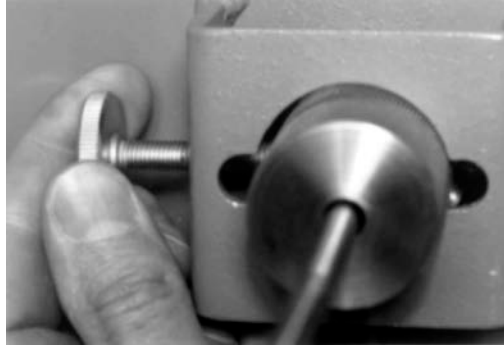
- 5.2.2.9 Tighten one connector locking screw (left or right, not both) to prevent rotation of the test cell and to place it in exactly the same position for each test.





Do not tighten both connector locking screws. If both are tightened, cooling fluid may leak.

---



**Figure 5-37 Tightening the connector locking screw**

5.2.2.10 Slowly close the shield door and push the door pin all the way down to lock the shield closed and to properly position the shear stress angle sensor in the top of the shield door.



Rapidly closing the shield door may cause the shear stress angle sensor to not achieve initial lock on the torsion magnet. The angle read will usually be obviously false and only last for a few seconds. The advanced control software will reestablish communication and lock automatically.

---



**Figure 5-38 Locking the shield door**

5.2.2.11 Refer to Figure 3-3 Digital Status Tab.

The Angle (deg) display will be used to properly set the Mechanical Zero.



---

f the Angle (deg) is not within  $\pm 2$  Degrees of the original saved value, the setup offset button will be grayed out and not selectable. If the Angle (deg) is not within  $\pm 4$  Degrees, the start test button will also be grayed out and not selectable. The magnet position has either slipped on the spring, the zero knob has slipped, or the torsion spring assembly has loosened at the upper pivot nut. The mechanical problem must be corrected before trying to set the Angle (deg) zero. The Angle (deg) zero is only properly adjusted or updated when there is no fluid sample in the cell.

---

### 5.3 Test Procedure – Mechanical

This section contains the steps representative of a typical procedure to set up and run a test. The operator is encouraged to modify the steps to meet his needs.

### 5.3.1 Load Sample into Cell

5.3.1.1 The mechanical zero of the test cell (less than  $\pm 2$  Degrees) should have been previously verified. This offset is used to calculate the shear stress measurement.

5.3.1.2 With the test cell in the test cell stand, remove the cell and the cap.

Place a new cell seal O-ring into its groove in the cell, just above the rotor. Do not reuse an O-ring seal.



---

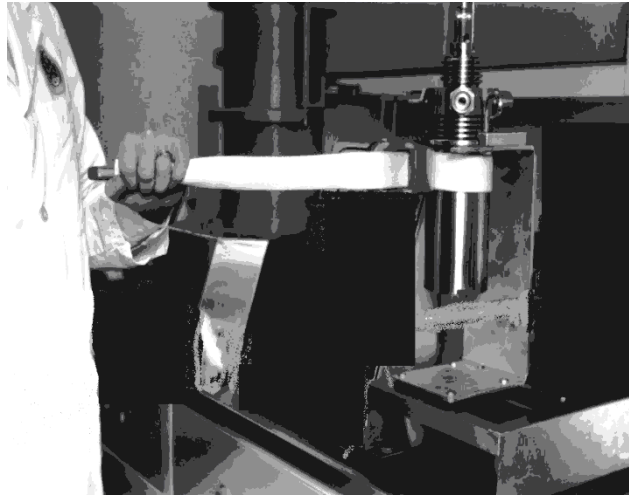
The backup ring is designed to prevent O-ring extrusion. Extrusion could lead to failure of the seal or severe difficulty in opening the test cell after a test. Failure of the O-ring with an abrasive sample could severely damage the cell and coupling by cutting the sealing surfaces in areas of high stress. The backup ring is easily damaged and must be handled carefully to avoid bending it.

---

5.3.1.3 Place the metal cell backup ring on the O-ring, with the flat surface facing up.



**Figure 5-39** Installing the cell seal O-ring and its backup ring



**Figure 5-40 Tightening the cell**

- 5.3.1.4 Pour 140 ml of sample into the cell without getting it on the threads of the cell or the seal. This sample volume reaches the top edge of the rotor. To remove any air pockets and completely fill the space, rotate the rotor with a ferrous tool, back and forth.
- 5.3.1.5 Slide the cell under the coupling on the stand. Then lift it up and screw the cell into place until it bottoms out.



---

Jewel or backup-ring damage will occur.

---

If resistance is felt before it reaches full make-up, then stop. The seal or backup ring might have slipped out of place or the torsion assembly may be jammed. Unscrew the cell and check the position of the backup ring, O-ring, cell baffle, and bob.

- 5.3.1.6 Tighten the cell, with the strap wrench provided, with moderate torque (20 foot pounds).
- 5.3.1.7 Inject 15 ml of the sample through the sample port to bring the level of the sample up in the coupling to just below the sample port. This step is important. If the level is too high, it leads to contamination of the pressurization fluid in the torsion spring area of the cap. If the level is too low, contamination of the sample with the pressurization fluid is possible.



**Figure 5-41** Injecting the sample



**Figure 5-42** Installing the cap seal O-ring and backup ring

- 5.3.1.8 Install a well seal O-ring if one is not already in place. Stretch it over the bottom of the cell and roll or slide it up. These O-rings may be reused until they become hard or un-pliable.

Slide a new cap seal O-ring into the groove around the base of the torsion spring assembly.



Metal Backup Rings are easily bent and must be handled carefully.

- 5.3.1.9 Place a cap seal backup ring over the O-ring with its flat face up.
- 5.3.1.10 Lower the cap carefully over the torsion spring assembly and screw it onto the coupling. If hard resistance is felt before full make-up by hand, stop and investigate. Use the strap wrench to tighten the cap with light torque. (12 ft/lbs) (16.3 n-m)
- 5.3.1.11 Inspect the O-ring on the sample port plug for damage, replacing it if necessary, and screw the sample port plug into place. Light hand torque is adequate.
- 5.3.1.12 Inspect the O-rings of the two port connectors on the iX77 for damage, and replace them if necessary.
- 5.3.1.13 Inspect the hot well to ensure that nothing has plugged the drain holes in the bottom, around the temperature sensor which projects up in the center.
- 5.3.1.14 If the pressurization fluid has been changed to a different fluid, flush the hydraulic lines and air operated pump. Fill the reservoir bottle with the correct fluid and operate the pump at 600–1000 psig until the new fluid is expelled from the port connector on the left side of the shield. Use a container to catch the old fluid as it is pumped out. It is not necessary to flush the old fluid from the port connector and tubing on the right side of the shield. Pressurization fluid should not be reused due to potential contamination, resulting in damage to the pump or other parts.



The test cell weighs 36 pounds (16.4 kg) and should be handled with two hands.

---

- 5.3.1.15 Remove the locking pin from the stand, remove the test cell and set it on its bottom on a bench.
- 5.3.1.16 Lift the test cell up and lower it into the hot well with the plugged sample port toward the front. A step stool may be useful if the bench is high.

- 5.3.1.17 Screw the two port connectors into place all of the way. Hand tight is adequate for good sealing. It may be necessary to rotate the test cell to line it up with the connectors. Do not lift it up or the well seal O-ring may be shifted out of position.
- 5.3.1.18 Tighten the single connector locking screw to prevent rotation of the test cell and to place it in exactly the same position for each test.
- 5.3.1.19 Slowly close the shield door and push the door pin all the way down to lock the shield closed and to properly position the shear stress angle sensor in the top of the shield door.



---

Rapidly closing the shield door may cause the shear stress angle sensor to not achieve initial lock on the torsion magnet. The angle read will usually be obviously false and only last for a few seconds. The advanced control software will reestablish communication and lock automatically.

---

#### 5.4 Test Cell – Mechanical

Normal test cell assembly is covered in *5.3 Test Procedure*. This section is intended to cover the situation where a component in the torsion assembly is replaced or something is done that alters its overall length. The torsion module is made up of the bob, bob shaft, the torsion spring assembly, and the pivots and jewels at each end. The most common use for this section will be when a jewel, usually the bottom jewel, is replaced.

The position of the bottom jewel, mounted in the bob, is very critical to the life of the jewel. The jewel can be screwed up or down to adjust the vertical position of the Torsion Assembly. Its position is locked by means of a socket head set screw above it. If the jewel is adjusted too far toward the top of the bob, two things may happen:

1. The pivot guide may rest on the post of the rotor, causing the bob to rotate with the rotor.
2. The limit stop may rest on top of the coupling when the test cell is pressurized. Either situation will result in erroneous viscosity measurements.

If the bottom jewel is adjusted too far toward the bottom of the bob, the jewel will be destroyed when the cell is assembled. This occurs because the torsion assembly is lifted on the Rotor Pivot as the cell is assembled. The motion of the torsion assembly upward is limited by the limit stop to protect the torsion spring and upper jewel. When the torsion assembly runs out of

freedom to move upward, great force develops at the bottom of the jewel vee where it is pressed by the sharp tip of the rotor pivot. It will crush the sapphire jewel. Any cracks in the bottom of the jewel vee will cause the torsion assembly to stick slightly, giving erroneous viscosity measurements and making calibration very difficult.

#### 5.4.1 Test Cell Setup

It is suggested the cell be placed on the preparation stand while performing the following procedures.



---

The numbers in brackets [ ] refer to the Test Cell Drawing, number 101511610.

---

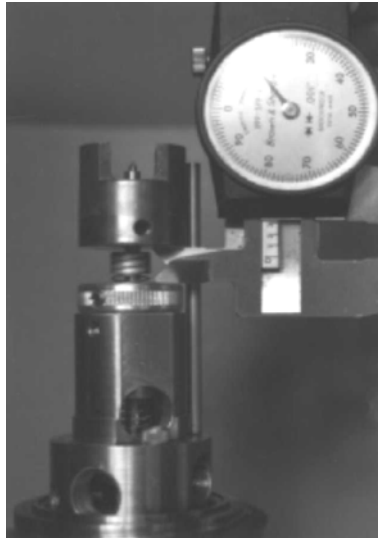
##### 5.4.1.1 Bottom Jewel Adjustment

- 5.4.1.1.1 The pivot guide [14] presses onto the bob [4]. With the set screw [16] and jewel [15] still out of the bob, use a soft material like a piece of plastic or wood to push the guide all the way onto the bob.
- 5.4.1.1.2 Screw the jewel all the way into the bob from the top until it stops. Do not force it. Lock it in place with the set screw.
- 5.4.1.1.3 Install the bob on the bob shaft [17] and install it in the coupling [1-1] in the normal manner. Make sure the baffle [2] is screwed tightly into place.
- 5.4.1.1.4 Loosen the #6 set screw in the side of the pivot cap [33]. Remove the pivot cap.
- 5.4.1.1.5 Measure the gap between the top of the zeroing sleeve [37] and the bottom of the upper magnet mount [32] (A). Refer to Figure 5-43 below. Now, gently lift the Torsion Magnet until it stops and measure the gap again (B). The difference between the two measurements (usually about 0.065 inch) (1.5 mm) is the total free movement of the torsion assembly (B – A). When screwing the cell [1-2] onto the coupling, the torsion magnet should rise about half that distance  $((B - A)/2)$ , which is about 0.030 inch (0.76 mm).
- 5.4.1.1.6 Loosen the two socket head cap screws that hold the torsion spring module to the coupling.



Loosen them so that the torsion spring assembly can be lifted at least 1/8 inch (5 mm). This prevents accidental destruction of the jewel if it is not adjusted correctly.

- 5.4.1.1.7 Place a backup ring and O-ring in the cell and screw the cell onto the coupling completely.



**Figure 5-43 Measuring the vertical movement of the torsion magnet**

- 5.4.1.1.8 Measure the gap between the top of the zeroing sleeve and the bottom of the upper magnet holder again. The torsion magnet should have risen half the total free movement. If it rose too far, the bottom jewel must be backed away from the pivot toward the top of the bob. If it did not rise at all or not enough, then the bottom jewel must be screwed further down. One revolution of the jewel adjusts the position by about 0.031 inch (0.79 mm).
- 5.4.1.1.9 Remove the cell and bob and adjust the jewel position as required. If the jewel must be screwed further in, first use the set screw to push the pivot guide down the required amount. Using the jewel to do this may damage it. Be sure to lock the jewel in position with the set screw. Be careful, sometimes the set screw will screw the jewel in further as it is tightened. Watch the jewel from the bottom of the bob while tightening the set screw to observe any jewel rotation.

5.4.1.1.10 Replace the cell on the Coupling and measure the gap again. If it is satisfactory, the two screws holding the torsion spring module can be tightened again.

#### 5.4.1.2 Top Jewel Adjustment

The top jewel is located at the top of the pivot cap and is mounted on a spring which helps to protect the jewels from shock and thermal expansion of the test cell.

5.4.1.2.1 Remove the Pivot Cap [33] and the Cap [1-3].

5.4.1.2.2 Remove the jewel [15] and clean the threads of the jewel and the upper pivot spring [35] with a non-oily solvent. It may be necessary to heat the jewel to about 212°F (100°C) to release any old thread locking compound.

5.4.1.2.3 Place a drop of thread locking compound such as LOCTITE 242 on the threads of the jewel and start it in the upper pivot spring.

5.4.1.2.4 Quickly adjust the top jewel with a screw driver so that the upper pivot spring [35] can just be seen to bend very slightly when the pivot cap is pushed all the way down to its normal position. It should bend about 1/64 inch (0.4 mm). Excessive bending will cause extra friction of the pivots and decrease the accuracy and repeatability.

5.4.1.2.5 Allow the pivot cap to sit undisturbed until the thread locking compound has cured.

#### 5.4.2 Torsion Spring Modules

Several torsion spring modules are available to optimize the iX77 Rheometer to the user's needs. Cells are normally supplied with the F1 torsion spring module. At 300 RPM the indicated dial reading reads apparent viscosity directly in centipoise. The following torsion spring modules are also available.

**Table 5-1 Torsion Spring Modules**

Designation	Torsion Spring Constant k (dyne-cm/deg)	Maximum Shear Stress with B1 BOB (dynes/cm <sup>2</sup> )	Part No.
F0.2	77.2	307	208950
F0.5	193	766	208951
F1	386	1533	208952
F2	772	3066	208953

The F0.2 module will read at five times the deflection of the F1 module for the same shear stress. The F0.5 module will read at twice the deflection of the standard F1 module. The F2 module will read at one half of the standard F1 module.

The spring modules are identical, except for the installed Torsion spring and its associated mandrels. They are supplied as complete Torsion spring Modules because it allows rapid switching from one to the other without readjusting the bottom jewel.



The calibration must be performed anytime a new spring module is installed, new bob is replaced, or any adjustments are made to the internal cell assembly. As a rule, anytime there is a question about whether or not to calibrate “then calibrate”.

All that is required is to remove the two screws that hold the torsion spring module to the top of the coupling and replace the module, pivot cap and calibrate. When installing a new torsion spring module, the top jewel must be adjusted for proper tension. This need be done only once, unless some component of the lower torsion assembly is changed, like the bob or lower jewel. The torsion spring assembly is shipped without locking the upper jewel into place with thread locking compound, to ease the initial installation. Follow the steps of *5.4.1.2 Top Jewel Adjustment*.

**5.4.3 Test Cell Disassembly and Cleaning**

Proper cleaning of the test cell is absolutely essential for reliable performance. Sealing surfaces that have not been cleaned can lead to seal failure and damage to the parts. Caked solids left in the torsion spring module may prevent proper rotation of the torsion shaft. If the jewel in the bottom of the bob is not cleaned, the same thing can happen.

The test cell should be cleaned as soon as possible after use to avoid corrosion and solids settling. The bushing in the center of the Rotor and its race on the top of the rotor pivot in the cell are made of hardened carbon steel. They will rust if left in corrosive fluids. This is a particular problem for the bushing in the rotor as rust may lock it into place. Corrosion may also affect the torsion spring and its locking mandrels. The mandrels are made of an aluminum alloy, and the spring is beryllium copper alloy. The aluminum, in particular, may suffer in a corrosive fluid.

A small ultrasonic cleaner does a good job of cleaning the torsion spring module, bob, and rotor. During tests at high temperatures and low pressures, the sample fluid often expands up into the torsion spring area. The cleaning solution must be selected based on the sample fluid and the pressurization fluid.

Oil based fluids are best cleaned by means of a parts washer like those used in automotive repair shops. A jet of solvent is very handy for removing stubborn cake in hard to reach places. Also, bottle brushes of various sizes are very handy. Small diameter brushes are most convenient for cleaning the 0.18 inch (4.6 mm) diameter holes in the coupling. A bottle type brush about 1.5 inches (38 mm) in diameter is very useful for cleaning the cell. It should be fairly stiff. Another bottle brush about 0.5 inches (13 mm) in diameter is good for cleaning the central bore of the coupling and the inside of the bob. The following steps are not necessarily in the most convenient order, but all should be included in a thorough cleaning.



---

The numbers in brackets [ ] refer to the Test Cell Drawing, number 101511610.

---

#### 5.4.3.1 Cell Disassembly

- 5.4.3.1.1 Unscrew the port connectors from the test cell in the tower. Leave the sample port plug in place. Some fluid will dribble from the left (pressurization) connector. The mess can be minimized by rotating the test cell in the tower and inserting small corks into the ports.
- 5.4.3.1.2 Place the test cell in the preparation stand, and lock it in place with the locking pin.
- 5.4.3.1.3 Unscrew the cell and set it below the bob until the upper portions of the test cell stop dripping,

to catch the drips. The strap wrench may be required to loosen it.

5.4.3.1.4 Unscrew the cap [1-3] and remove it. The strap wrench may be required on it also.

5.4.3.1.5 Remove the rotor assembly [3] from the cell [1-2] and set it on a non-magnetic surface away from magnet materials, to drain. It is always best to set the rotor down with the magnet end up. This helps to avoid collecting nearby magnetic materials on the drive magnet.

5.4.3.1.6 Pour out the contents of the cell and allow it to drain. If the rotor has not been removed, be sure to prevent it from falling out of the cell by holding it with a finger.



---

The drive magnet [6] used in the iX77 is a very high energy magnet. It is composed of samarium, cobalt, iron, zirconium, copper and rare earths. Extreme care should be taken to prevent the magnet from being inadvertently attracted to another magnet or to any ferrous object. Pinching could occur. Also, the material is brittle and could shatter upon impact. Two of these drive magnets will attract each other from several inches away. The magnet should also be kept away from sensitive mechanical devices such as wrist watches and meters. Magnetic data recording media like computer disks and tapes and credit cards should also be kept well away.

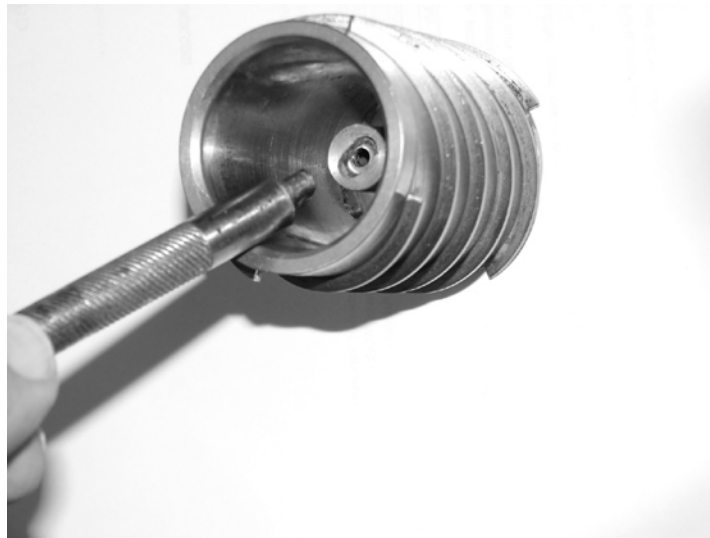
---

#### 5.4.3.2 Rotor Disassembly

5.4.3.2.1 Remove the two slotted head screws [11] in the bottom of the rotor. Lift off the magnet holder [7] and press out the bronze rotor bushing [8] in the bottom of it. Remove the drive magnet [6] and place it on a non-magnetic surface. It should be cleaned separately. Place all of the parts except the drive magnet in cleaning solution or ultrasonic cleaner and clean them thoroughly. Do not attempt to clean the drive magnet in an ultrasonic cleaner as it may damage the cleaner.



**Figure 5-44 Disassembling the rotor**



**Figure 5-45 Removing the bushing [12]**

- 5.4.3.2.2 Remove the rotor from the cleaning solution and use the removal tool oval-shaped end to press the bushing [12] out of the middle of the rotor. A small hammer may be used to gently tap the bushing out, but be careful because the bushing is brittle and may shatter, making removal difficult. Thoroughly clean or replace the bushing. Use a brush to clean the small bore of the rotor.

### 5.4.3.3 Cell Top Disassembly

- 5.4.3.3.1 Remove the pivot cap [33] at the top of the test cell by loosening the #6 set screw on its side, about 2 turns, and lifting the cap off. This exposes the torsion magnet [34]. Note whether solids are evident in the torsion spring [30-1-7] area. If they are, special diligence will be required to make sure the spring is clean.
- 5.4.3.3.2 Grasp the bob [4] and unscrew the bob and bob shaft [17] from the torsion spring module at the top. Turn the bob clockwise when viewed from above. The bob may unscrew from the bob shaft. If it does, place a small rod through the holes in the bob shaft and unscrew it. If not already separated, unscrew the bob from the bob shaft and place them in the cleaning solution. In cleaning the bob, special care must be taken to remove caked solids from the top recess where the bob shaft screws in and the vee jewel [15] and pivot guide [14] on the bottom. A small stiff brush and a wash bottle filled with a suitable solvent are handy for this. Run a brush through the bob shaft to clean the bore.



---

Handle the torsion spring module with care. Rough handling may change the calibration. The torsion magnet [34] is relatively easy to move on its shaft. That would result in a change in the mechanical zero.

---

- 5.4.3.3.3 Remove the two socket head cap screws [28] that hold the torsion spring module to the coupling [1-1] (refer to Figure 5-46). Place the torsion spring module into the cleaning solution. This module must be cleaned carefully. Make sure that any caked solids in and around the pivot stop [25] and the torsion spring are removed. A jet of cleaning solution is useful.



**Figure 5-46 Removing the torsion spring module**

5.4.3.3.4 Use a small magnet to lift and retain the small ball [39] that was underneath the spring module, on top of the coupling (refer to Figure 5-47). This ball acts as a check valve to prevent excessive dribbling of pressurization fluid when the port connectors are disconnected in the tower.

#### 5.4.3.4 Disassembly of the Coupling

5.4.3.4.1 Unscrew the baffle [2] from the bottom of the coupling and wash it in the cleaning solution. Use a small brush to clean its bore and threads.

5.4.3.4.2 Remove the sample port plug from the coupling and clean it in the cleaning solution. A small brush is helpful. Inspect the O-ring and if damaged, remove and replace it.

5.4.3.4.3 Remove the coupling from the stand and wash it. Be sure to run a brush through the central bob shaft bore, the three ports, the sample port bore from the bottom of the coupling, and the two bores at the top of the coupling and the two threaded holes. Use a brush to scrub the large threads of the coupling at each end. While cleaning, do not scratch the top and bottom surfaces of the coupling because they are sealing surfaces. Set the coupling on its side rather than on its ends.



5.4.3.4.4 Rinse the parts and use an air jet to dry them off. Be especially careful to dry the spring module to prevent corrosion.

5.4.3.4.5 Use a solvent-moistened cotton-tipped applicator to carefully clean the vee jewel in the pivot cap and in the bob.

The test cell parts are now ready for re-assembly after inspection.

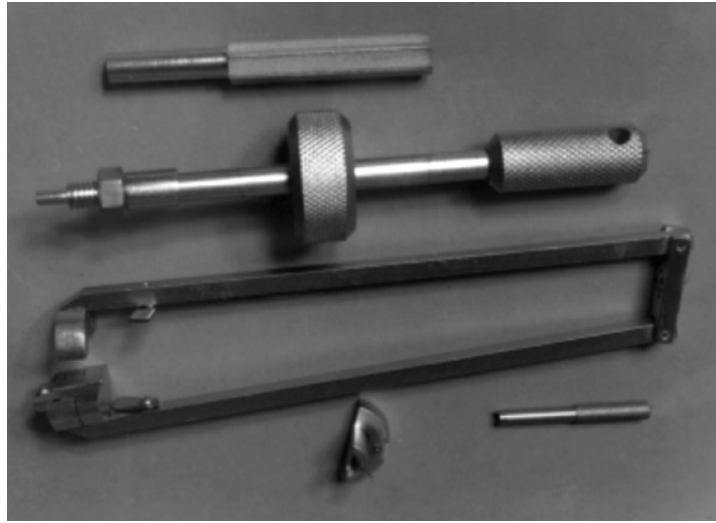


**Figure 5-47 Location and orientation of the ball under the torsion spring module**

#### 5.4.4 Rotor Busing Replacement

Four parts of the rotor busing system must be replaced periodically. These are:

1. The bushing inner and outer race [12], which the outer race is mounted in the center of the Rotor and rotates with it.
2. The bushing inner race, which is mounted near the top of the pivot/thermowell in the center of the cell and is stationary.
3. The rotor bushing [8], which is pressed into the base of the rotor assembly and rotates with it.
4. The pivot bushing [10], which is also stationary and mounts on the pivot/thermowell at its base, in the cell cavity.



**Figure 5-48 Tool set**



The numbers in brackets [ ] refer to the Test Cell Drawing, number 101511610.

The following describes how to remove and replace each one.

#### 5.4.4.1 The Bushing [12] Outer Race

##### 5.4.4.1.1 Removal

The oval-shaped end of the removal tool (209165) is used to push the outer race from the rotor. First remove the drive magnet and the magnet holder by removing the two screws that hold the assembly together. Place the rotor [3] on the bench with the closed end down.



**Figure 5-49 Rotor and bearing removal tool**

Insert the small oval-shaped end of the bearing removal tool into the small hole in the end of the post in the center of the rotor. It will go in slightly, stopping on the bushing race. Push firmly, straight down, and the bushing race will pop loose from its seat. A gentle tap from a small hammer may be necessary to make it pop loose. The tool should only be tapped if the round shoulder is above the rotor surface.

#### 5.4.4.1.2 Installation

Wipe a small amount of the supplied anti-seize compound on the outer surfaces of the race. Then use the round end of the bushing pressing tool. It is round on one end and hexagonal on the other. Push the bushing all the way into the rotor firmly. Try not to use the slide hammer. If you must use the slide hammer, do it gently to avoid damaging the bushing. If the bushing is not pushed all the way in, the lower vee jewel may be damaged when the test cell is assembled.



**Figure 5-50** Placing the bushing outer race in place for pressing

#### 5.4.4.2 The Bushing [12] Inner Race

##### 5.4.4.2.1 Removal

The inner race is removed by using the slide hammer and the puller, which has two pivoted arms. Onto the fittings at the end of each arm, first attach the small adapter fitting which enables the arm to close around and grasp the race. A slot in the adapter fitting engages the rim of the race on each side. After placing the adapter fitting over the pin on each arm, rotate the lock to hold it in place. Screw the puller onto the threaded end of the slide hammer. Separate the arms slightly and lower them into the cell on each side of the pivot. Close the arms on the inner race, engaging the slots with the rim of the race. A few light taps of the weight on the slide hammer against the stop on the end away from the cell should remove the race.



**Figure 5-51 Removing the bushing inner race or the pivot bushing**

#### 5.4.4.2.2 Installation

Before installing the race, make sure that the pivot bushing [10] has been installed at the base of the pivot/thermowell [5] in the cell. It can not be installed with the inner race in place. Clean both the inner race and the small end of the pivot/thermowell where it mounts, with a non-greasy solvent. Allow them to dry. Then apply a drop of high-temperature thread locking compound to the hole in the inner race. Use pliers to start the inner race on the pivot with the flat side down. Use the round end of the ball bearing pressing tool. Push straight down on the race with the round end until the race is at the bottom of the small-diameter section of the pivot. Do not use the slide hammer. The race is made of a brittle material and may shatter. Wipe any excess locking compound from the race and the pointed end of the pivot. Refer to the figures on the next page.

#### 5.4.4.3 The Rotor Bushing [40]

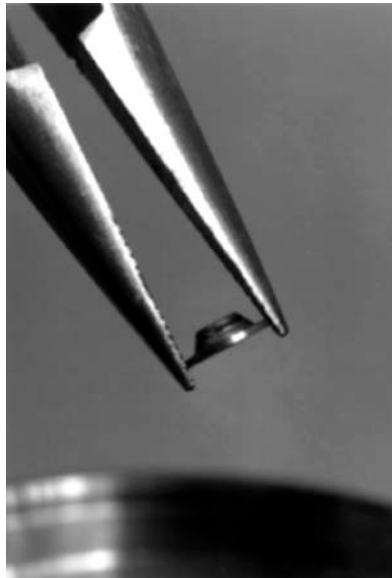
##### 5.4.4.3.1 Removal

Removal of the rotor bushing is described in more detail in 5.4.3.2 *Rotor Disassembly*. Basically, it is just pushed out by hand from the drive magnet

holder [7] after the holder has been detached from the rotor [3].

#### 5.4.4.3.2 Installation

Set the rotor down with the open end down. Set the magnet holder on the Rotor with the slotted end down. Then rotate it until the two screw holes line up with the corresponding holes in the rotor. Install the two screws [11] and tighten them snugly. Now slide the drive magnet [6] into the slot until it is roughly centered. Push the rotor bushing into the hole in the magnet holder and into the drive magnet until it stops. This helps to temporarily retain the magnet. Visually center the drive magnet so that it does not protrude more on one side than the other and tighten the #8 set screw [44] in the magnet holder. This locks the drive magnet into position.



**Figure 5-52 Positioning the bushing inner race**



**Figure 5-53** Pushing the inner race onto the pivot



**Figure 5-54** Placing the drive magnet into position



**Figure 5-55** Pushing the rotor bushing into position



**Figure 5-56** Locking the drive magnet

#### 5.4.4.4 The Pivot Bushing [43]

##### 5.4.4.4.1 Removal

First remove the angular contact bushing inner race (Refer to *5.4.4.2 The Angular Contact Bushing [12] Inner Race*). Like the inner race, the pivot bushing is removed with the puller and the slide hammer. First, screw the puller onto the threaded end of the slide hammer. Then remove the two inner race adapters from the ends of the arms, if they are installed. The circular slot in the fittings at the end of the arms is designed to engage the flange at the



bottom of the bushing. Separate the arms of the puller a little and lower them to the bottom of the cell around the pivot/thermowell [5]. Now close the arms of the puller, engaging the slots on the bushing flange on each side. Hold the arms closed with one hand and slide the weight of the slide hammer up with the other, banging it against the stop away from the cell. After a few moderate blows, the bushing should break loose.

#### 5.4.4.4.2 Installation

The installation of the pivot bushing is essentially the reverse of the removal. The slide hammer is used to drive it into position by striking the stop closest to the cell with the slide hammer weight. Do not use any locking compound when installing the bushing. Make sure it is driven all the way down. Check this by putting the rotor in the cell and confirming that the bushing is supporting it, and not the bushing at the bottom. If it is not all the way down, the uplifted rotor will push against the bob when the test cell is assembled, preventing proper rotation of the bob.



**Figure 5-57 The Pivot Bushing in the groove of the Puller**

#### 5.4.5 Vee Jewels

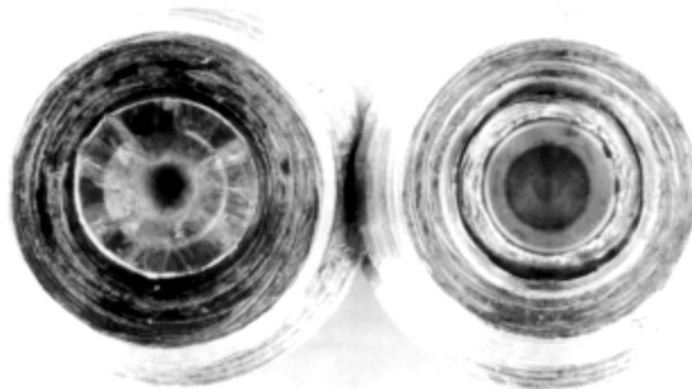
The vee jewels [15] that are used to support the top and bottom of the test cell torsion assembly are constructed of clear synthetic sapphire and mounted in a stainless holder. They are most often damaged when excessive force on the torsion assembly jams the

jewel onto the point of the pivot, shattering the jewel. This may occur when the bottom or top vee jewels are not adjusted correctly, or if the torsion assembly is dropped onto the lower pivot. Any surface cracks in the spherical apex of the jewel vee will cause sticking of the torsion assembly, and a reduction of the Rheometer's accuracy. The vee jewel in the bottom of the bob is the one most frequently damaged. The top vee jewel is protected to some degree by the "X" shaped pivot spring [35] on which it is mounted.

Remove the bob or pivot cap and clean the vee jewel for inspection by spinning the tip of a solvent-moistened cotton-tipped applicator in the jewel vee. This should remove any surface contamination.

The vee jewels are best inspected by means of an optical microscope with reflected light. A magnification of 40 has been found suitable. Lighting is a little difficult, but the jewel in the bottom of the bob can be inspected without removing it. The jewel may appear dark if a dark fluid has been forced behind it by the operating pressures. Tilt the jewel so the light hits it at various angles to help highlight any cracks. The focus of the microscope should be moved up and down the depth of the vee to sharply focus all parts of the vee's conical surface. Pay special attention to the curved surface at the bottom of the vee.

If any surface cracks are found, the vee jewel should be replaced. Don't mistake any fibers left from the cotton-tipped applicator as cracks. (Refer to *5.4.1 Test Cell Setup* for instructions on proper adjustment of the replacement jewel.)



**Figure 5-58** Comparison of bad (left) and good (right) jewels

## 5.5 Calibration – Mechanical

The iX77 Rheometer is designed to be calibrated with certified calibration fluids available from Fann Instrument Company. These fluids are Newtonian silicone oils and are available in a number of viscosities. The viscosity tables supplied with the fluids are traceable to the National Institute of Standards and Technology.

The Rheometer will retain its calibration as long as the torsion spring module is not disassembled and is kept clean and corrosion free. Removing the spring cage assembly from the top of the coupling as a unit should have only a minor effect on the mechanical zero.

The iX77 Rheometer uses a smart digital magnetometer to detect the rotation of a magnet at the top of the torsion assembly. The influence of the powerful drive magnets inside of the shield, the earth's magnetic field, the magnetic properties of the shield, spring non-linearities, magnetic fields and masses in the laboratory, non-ideal fluid flow, and small geometry variations all combine to make the angle display non-linear if not compensated. The advanced control software allows easy compensation for those effects.

#### 5.5.1 Setting the Mechanical Zero

The mechanical zero of the test cell torsion assembly is the angle to which the torsion assembly rotates with no fluid in the cell. The zero point is determined by the rotational position of the zeroing sleeve and the torsion magnet. These parts are all located in the top of the test cell, under the cap.



---

Rapidly closing the shield door may cause the shear stress angle sensor to not achieve initial lock on the torsion magnet. The angle read will usually be obviously false and only last for a few seconds. The advanced control software will reestablish communication and lock automatically.

---



---

The numbers in [ ] refer to the Test Cell Drawing, number 101511610.

---

5.5.1.1 Place the assembled test cell into the hot well. Connect the port connectors and tighten one connector locking screw. This places the cell in exactly the position it would be in for a normal test.

5.5.1.2 Remove the test cell cap.

- 5.5.1.3 Use a non-magnetic, non-ferrous tool (an ordinary wooden pencil is good) to gently push the torsion magnet [34] in a counter-clockwise direction until it stops. Note the amount of return rotation. It should rotate 1 to 3 degrees. If it does not, loosen the set screw [44] in the spring cage [33] that locks the zeroing sleeve [37] in place. Rotate the zeroing sleeve as required and retighten the set screw. Check the rotation again before proceeding.
- 5.5.1.4 Slowly close the shield door and lock it in place with the locking pin.

If the Angle (deg) from the Digital Status page is greater than 2.5 degrees, then continue with this procedure.

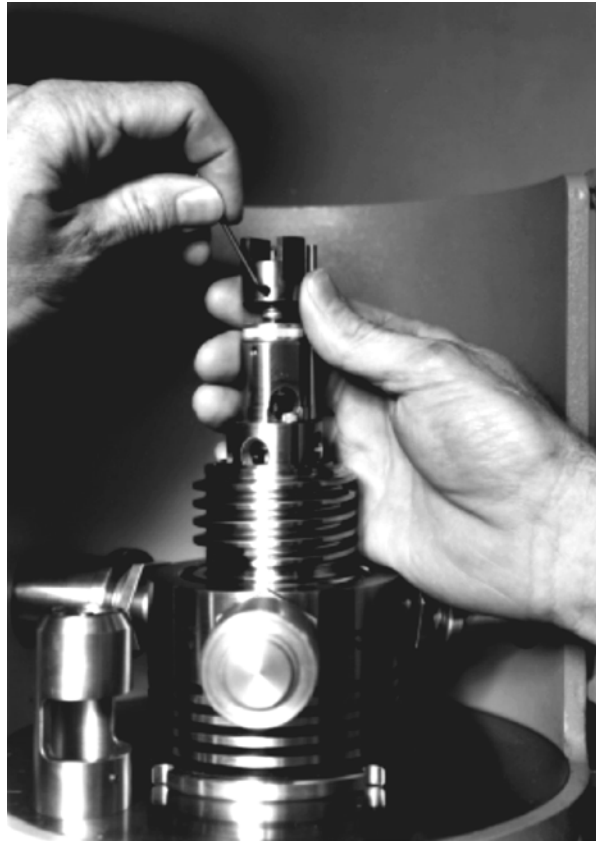


**Figure 5-59** Adjusting the zeroing sleeve



**Figure 5-60 Removing the pivot cap**

- 5.5.1.5 Open the shield door and note the clearance between the top of the torsion magnet [34] and the bottom of the upper pivot spring [35]. It should clear by about 1/32 inch to 1/16 inch (1 mm to 2 mm). Remove the pivot cap [33] by loosening its set screw at least two turns. This exposes the torsion magnet [34] and its set screw that locks it to the upper pivot pin [30-2].
- 5.5.1.6 Note the clearance between the bottom of the rotating torsion magnet [34] and the top of the stationary grip mandrel [30-3]. It should be 1/32 inch (1 mm) or more. Loosen the torsion magnet set screw and rotate it counter-clockwise to correct for excessive positive Angle (deg) or clockwise for a negative Angle or an Angle above 320 (deg)s. Tighten the set screw securely at the same clearance above the torsion spring as before. The torsion magnet should be quite close but must not touch the top of the torsion spring.



**Figure 5-61 Adjusting the torsion magnet position**

- 5.5.1.7 Replace the pivot cap. Check to be sure that the torsion magnet [34] just clears the underside of the upper pivot spring [35] as noted in step 5.5.1.3. Repeat steps 5.5.1.5 through 5.5.1.7 until a near zero (0) Angle (deg) reading is attained.



---

Handle the torsion spring module carefully during cleanup and re-assembly so that the mechanical zero settings do not have to be reset again.

---

- 5.5.1.8 Open the shield top, replace the cell cap, and close the shield top again.
- 5.5.2 Calibrating the Torsion Spring

The basic torsion spring calibration is not overly critical because the Advanced Control Software will correct for minor torsion constant errors during the automatic calibration procedure. Adjustment is achieved by making the effective length of the

spring longer or shorter. The spring is shortened to cause the torsion shaft to rotate less within a given load. More rotation results when the effective length is increased. The torsion springs are factory calibrated and should not normally require adjustment. However, it may be recalibrated, if desired, by the steps as outlined below.



---

The numbers in brackets [ ] refer to the Test Cell Drawing, number 101511610.

---

#### 5.5.2.1 Torsion Spring Recalibration

Follow the steps 5.5.1.1 through 5.5.1.8 of *5.5.1 Setting the Mechanical Zero*, except fill the cell with the appropriate calibration fluid (commonly 200 cP with the F1 spring).

- 5.5.2.1.1 Operate the Rheometer at a speed of 300 RPM (for 200 cP fluid).
- 5.5.2.1.2 Note the displayed Angle (deg) and Temperature.
- 5.5.2.1.3 Compare the Angle (deg) to the Calculated Angle (Centipoise), from the calibration fluid table, for the indicated temperature. An error of  $\pm 2$  cP is acceptable. If adjustment is required, continue to the next step.
- 5.5.2.1.4 Stop the Rheometer, open the shield door, and remove the cap [1-3] from the test cell.
- 5.5.2.1.5 Note the clearance between the top of the torsion magnet [34] and the bottom of the upper pivot spring [35]. It should clear by about 1/32 inch to 1/16 inch (1 mm to 2 mm). Remove the pivot cap [33] by first loosening its set screw at least two turns.



**Figure 5-62** Removing the pivot cap



**Figure 5-63** Adjusting the torsion spring length





The torsion shaft assembly is supported at the center of the bob [4] on a sapphire vee jewel [15]. If the assembly is lifted and allowed to drop on the bottom pivot, it may damage the vee jewel. This will destroy the accuracy of the instrument and require replacement of the vee jewel. Removing the torsion magnet [34] could inadvertently lift the torsion shaft assembly.

5.5.2.1.6 Note the orientation of the torsion magnet [34] set screw to aid in re-assembly. Also note the clearance between the bottom of the rotating torsion magnet [34] and the top of the stationary grip mandrel [30-3]. It should be 1/32 inch (1 mm) or more. Loosen the set screw and remove the torsion magnet.

5.5.2.1.7 Unclamp the top spring mandrel [30-4] by loosening the set screw [49] in the zeroing sleeve [11].

#### 5.5.2.2 Rotate Top Spring Mandrel

Use a calibration tool (Part No. 208945) to rotate the top spring mandrel slightly. Turn it counter-clockwise when viewed from the top to lengthen the spring. Turning it clockwise will shorten it. One quarter revolution will change the angle reading by about 3 percent. Visualizing the amount of rotation is easier if an index mark is placed on the end or side of the calibration tool. It is easier to make adjustments if you turn the loosened spring assembly against the stop in the direction you are going to adjust then turn the calibration tool

#### 5.5.2.3 Reassembly

Reassemble as described below:

5.5.2.3.1 Re-clamp the top spring mandrel with the set screw in the zeroing sleeve. Make sure that the top of the top mandrel is even with the top of the clamping sleeve [31]. The spring might have to be stretched or compressed slightly to accomplish this step.

5.5.2.3.2 Install the torsion magnet and position it at the same clearance above the spring grip as noted before. The clearance between the bottom of the rotating torsion magnet [34] and the top of the stationary grip mandrel [30-3] should be 1/32 inch (1 mm) or more. The torsion magnet

- should be quite close but must not touch the top of the torsion spring. Tighten its set screw.
- 5.5.2.3.3 Install the pivot cap, pushing it all the way down, and tighten its set screw. When properly adjusted, the upper pivot spring [35] should bend very slightly upward without touching the torsion magnet. If the upper pivot spring bends more than about 1/64 inch (0.4 mm), the Top Jewel Adjustment procedures of 5.4.1 *Test Cell Setup*, should be performed. If the upper pivot spring touches the torsion magnet, the magnet must be repositioned lower on the upper pivot pin [30-2].
- 5.5.2.3.4 Follow the procedures of 5.5.1 *Setting the Mechanical Zero*.
- 5.5.2.3.5 Repeat steps of this section until the error is below  $\pm 2$  cP.



---

The calibration must be performed anytime a new spring module is installed, new bob is replaced, or any adjustments are made to the internal cell assembly. As a rule, anytime there is a question about whether or not to calibrate “then calibrate”.

---

## 5.6 Chiller Operation

The optional chiller is used to cool the cell below room temperature for cold water testing. The chiller temperature range is  $-10^{\circ}\text{C}$  to  $35^{\circ}\text{C}$  depending on the antifreeze used. The iX77 will control the chiller operation when properly connected to maintain a user selected temperature.

A DB9 style cable connects the chiller to the controller in the iX77. On the calibration tab, select the “Chiller Enable” button. When the chiller is on and connected, a red dot will appear on the chiller panel indicating that it is communicating and being controlled by the iX77.

If the iX77 software is not in current use, the chiller operation can also be selected by modifying the config\_M77.ini file located in C:\Program Files\Fann\M77. The user must ensure that both instances of UseChiller=FALSE are changed to UseChiller=TRUE.

The test cell must be held in place when the chiller is in operation. Otherwise, the back pressure from the chilled water loop will cause a water leak at the test cell. New iX77 Rheometers have a pre-installed hold down

clamp in the tower door. If this clamp is not present, order kit 101893838 from Fann Instrument. This clamp can be easily added to the instrument at the customer location.

Ensure that grease has been placed along the OD of the test cell O-ring before the test cell is installed in the hot well. This will allow the O-ring to slide freely and properly seat in the hot well.

## 6 Analyzing Results

This page left intentionally blank.

## 7 Troubleshooting and Maintenance

### 7.1 Pressure

**Table 7-1 Pressure**

Symptom	Possible Cause	Solution
Pump runs, but pressure does not increase	Fluid level in pressurizing fluid reservoir lower than pickup tube	Fill pressurizing fluid reservoir
	Excess air in hydraulic system	Purge air using manual release valve
	Rupture disc burst	Observe for continuous fluid return in waste bottle with manual release valve closed; replace rupture disc
	Blocked suction line filter	Replace filter or filter element
Pump does not run	No air supply	Verify air supply
	Faulty electronic air pressure regulator or pump	Call for FANN service
Frequent pumping	Leaking cell cap, cell bottom, or port connector O-rings	Inspect connections for leaking fluids and replace O-rings as indicated
	Dump valve or control valve not seating	Manually reset dump valve Replace kit in control valve
	Leaking fittings	Inspect weep holes at all high-pressure fittings and tighten as indicated
Will not vent pressure	No air supply	Verify air supply
	Faulty air operated relief valve, air pressure regulator, or air operated control valve	Call for FANN service
	Blocked high-pressure filter	Slowly manually release pressure, remove filter, and clean or replace filter elements
	Blocked flow-restriction tubing	Disassemble, clean, and reassemble. Do not over tighten high-pressure fitting.

## 7.2 Tescom Valve Maintenance

### 7.2.1 Tools Needed

The following items are needed to complete valve repair:

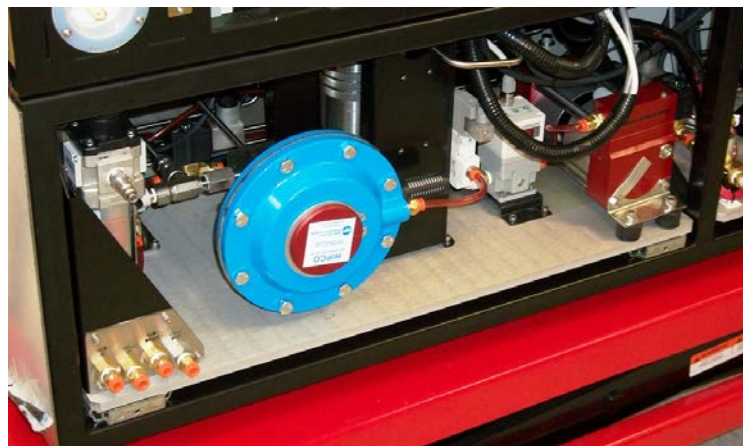
- 2 ½ inch open end wrench (101582697)
- 2 inch open end wrench (101582698)
- Repair Kit (101629337)
- Torque Sensor Tool (101629332)
- Loctite 271
- A light lithium or silicone based grease

### 7.2.2 Front Panel Removal

7.2.2.1 Remove the cell assembly from the tower. The weight of the cell could cause the instrument to tip when the drawer is opened.

7.2.2.2 Remove power and air from the iX77.

7.2.2.3 Ensure the water and drain lines have enough slack to move forward without binding.



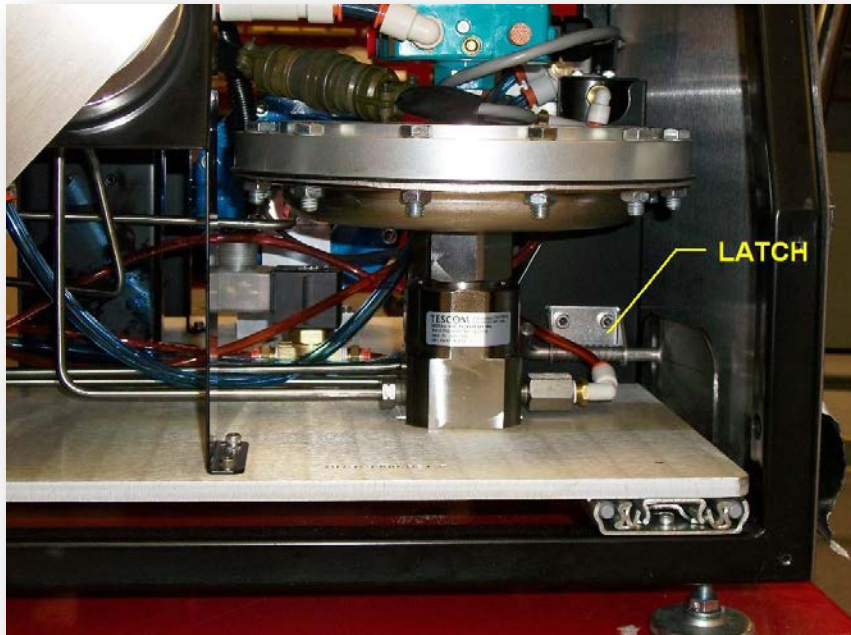
**Figure 7-1 Rear Fluid Connections**

7.2.2.4 Remove the six screws from the sides of the front panel.

7.2.2.5 Pull the oil bottle drawer out.

7.2.2.6 Rotate the front panel gain access to the Tescom valve.

7.2.2.7 Locate the latch behind the Tescom valve.



**Figure 7-2 Drawer Latch Location**

7.2.2.8 Push the latch sideways and pull the bottom drawer out.



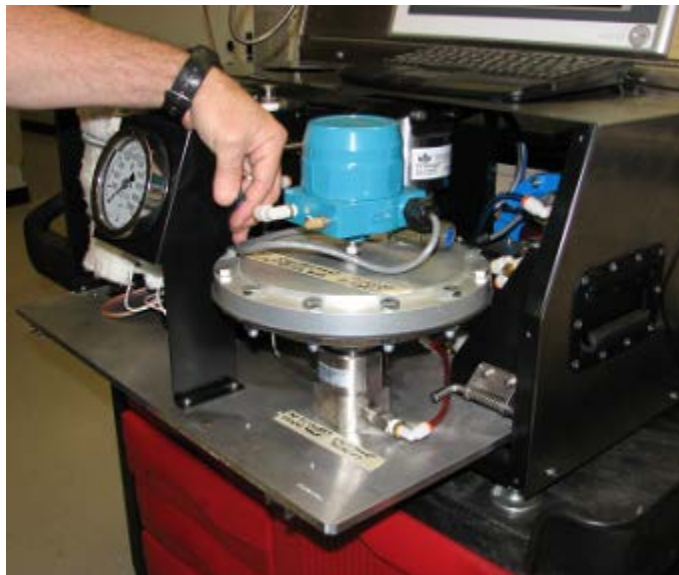
**Figure 7-3 Opened Drawer with Rotated Front Panel**

7.2.2.9 Disconnect the control cable.



**Figure 7-4 Control Cable**

7.2.2.10 Remove the air inlet tubing.



**Figure 7-5 Air Inlet Tubing**

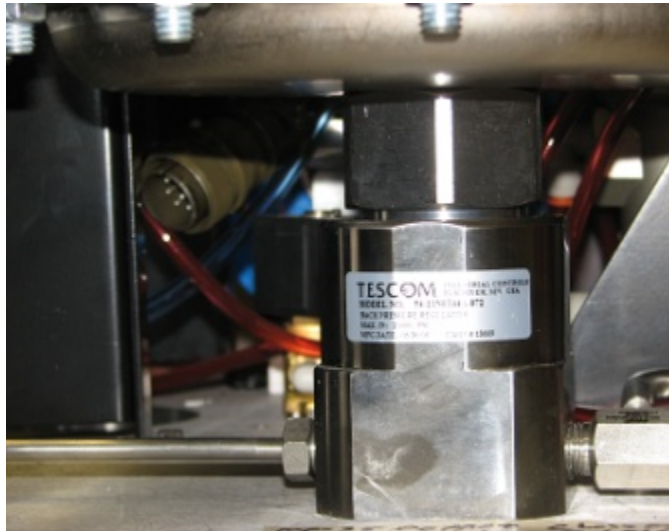


7.2.2.11 Use the 2 and 2-1/2 inch wrench for valve disassembly.



**Figure 7-6 Wrenches for Valve Disassembly**

7.2.2.12 Ensure there is ample clearance to use the wrenches.



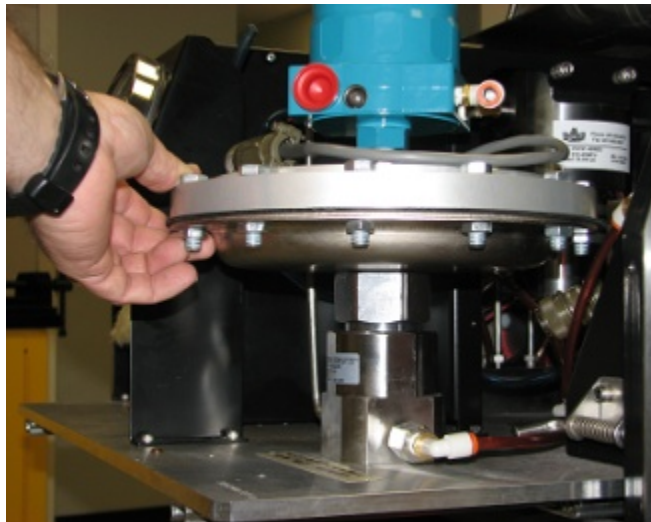
**Figure 7-7 Clearance in the Disassembling Area**

- 7.2.2.13 Loosen the right hand threaded Body Assembly from the Air Actuator Assembly.



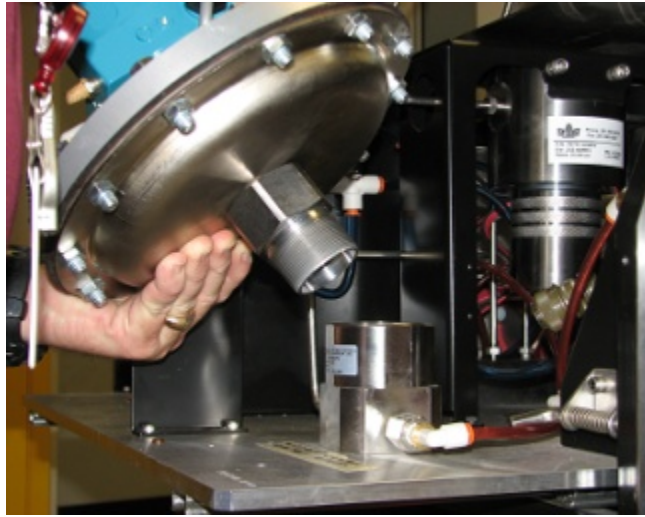
**Figure 7-8 Body Assembly/Air Actuator Assembly**

- 7.2.2.14 Spin the valve off by hand once it is loosened.



**Figure 7-9 Valve Disassembly**

- 7.2.2.15 Remove and set the Air Actuator Assembly aside.



**Figure 7-10 Air Actuator Assembly**

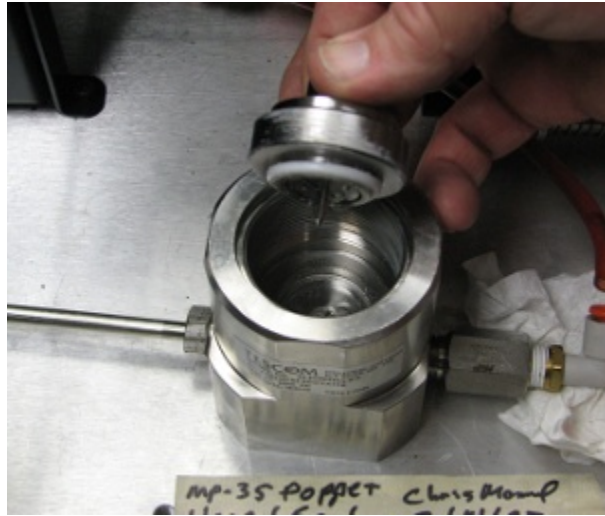
### 7.2.3 Rebuilding Internal Valve Body

The following steps are performed to rebuild the internal valve body including all stems, seats, and seals.

- 7.2.3.1 Locate and remove the internal sensor assembly.

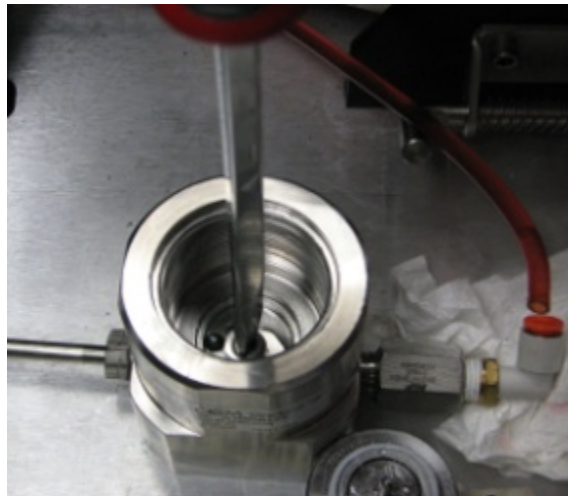


**Figure 7-11 Internal Sensor Assembly Location**



**Figure 7-12 Internal Sensor Assembly Removal**

7.2.3.2 Remove the Seat Retainer with a medium flat blade screw driver.

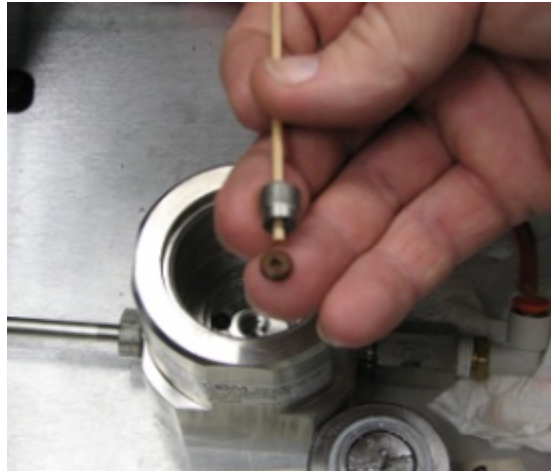


**Figure 7-13 Seat Retainer**

7.2.3.3 Lubricate and reinstall the threads. After the lubrication, replace the seat in the retainer.



Refer to the valve drawings and BOM in this document for detailed parts and lubrication information.



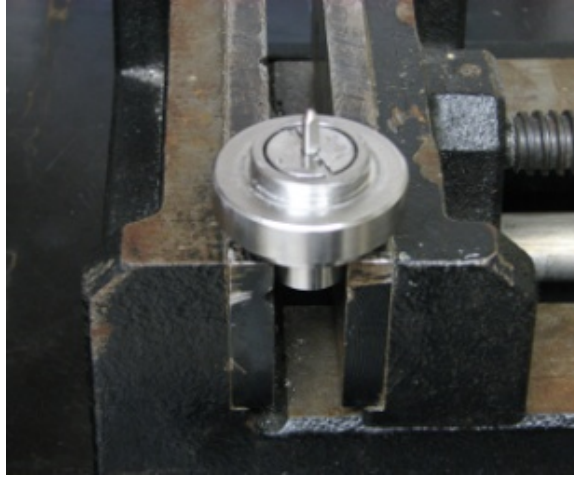
**Figure 7-14 Lubrication of Threads**

7.2.3.4 Use the torque sensor tool to disassemble and reassemble the sensor.



**Figure 7-15 Torque Sensor Tool**

7.2.3.5 Using soft jaws, chuck the flats on the sensor assembly in vise with the stem facing up.



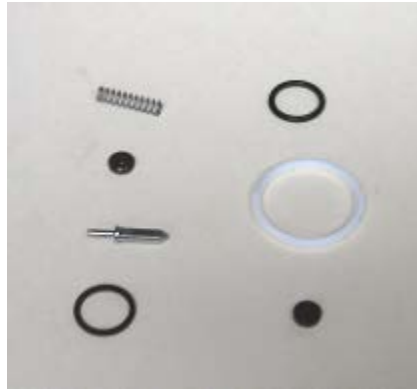
**Figure 7-16 Soft Jaws**

7.2.3.6 Unscrew the sensor from the spring pad.



**Figure 7-17 Spring Pad**

7.2.3.7 Replace the sensor and valve parts (as shown below). Reassemble the parts.



**Figure 7-18 Valve Parts**



**Figure 7-19 Stem and Spring**



**Figure 7-20 O-ring and Backup Ring**

7.2.3.8 Before assembling the Spring Pad and Sensor, apply one drop of Loctite on the threads.



**Figure 7-21 Loctite Application**

7.2.3.9 Reassemble in reverse order using the valve drawings as a reference.



---

Observe the torque and lubrication requirements in the drawing notes.

---



**Figure 7-22 Reassembled Sensor**



**Figure 7-23 Lubricated Threads**



**7.3 Temperature**

**Table 7-2 Temperature**

Symptom	Possible Cause	Solution
Does not heat	System automatically sensed problem in heating time	Reset heat fault
	Heater failed	Call Fann Instrument Company.
	Thermocouple failed	Call Fann Instrument Company.
	Bad solid state relay	Call Fann Instrument Company.
Post test Cool Down fails	Cell temperature below 100°F	None, cool down disabled below 100°F
	No water supply	Verify water supply
	Faulty cooling valve or cooling valve solenoid valve	Call Fann Instrument Company.
	Blocked drain hose	Verify drain hose is open
Does not chill to set temperature	Low-pressure output from external chiller	Verify chiller output pressure and repair as indicated
Cooling water leaks around test cell	Cell to heater well O-ring damaged	Inspect and replace as indicated
	Heating well drain holes blocked	Clean
	Drain hose too small or too high	Replace with larger hose or adjust to lower than system

**7.4 General**

**Table 7-3 General**

<b>Symptom</b>	<b>Possible Cause</b>	<b>Solution</b>
Angle reading does not change or changes erratically	Baffle unscrewed against bob	Tighten baffle and inspect bottom vee jewel for damage
	Bob shaft assembly bent	Straighten
	Torsion magnet touching upper pivot spring	Adjust magnet position and inspect bottom vee jewel for damage
	Bottom vee jewel adjusted too far down	Inspect for damage and adjust
	Debris between torsion magnet and pivot cap	Clean
	Dirty vee jewels	Clean and inspect for damage with microscope
	Solids caked around torsion spring or limit stop	Thoroughly clean torsion spring module
	Faulty magnetometer	Call for FANN service
Unexpected angle readings, but correct with calibration fluid	Cell bearings or bushings worn	Check pivot bushing, rotor bushing and bronze race bushing for wear (0.0156 inch max vertical movement at rotor edge) and replace as indicated
	Rotor speed calibration incorrect	Confirm rotor speed with optical tachometer and adjust motor control board
	Rotor and magnet holder incorrectly assembled	Loosen magnet set screw and verify rotor and magnet holder squarely seat, tighten set screw
	Inadequate calibration fluid volume in cell during calibration	Recalibrate with correct fluid volume
	Contaminated fluid during calibration	Clean cell and recalibrate with fresh calibration fluid
	Wrong calibration chart used	Recalibrate with correct calibration chart for fluid being used



## 8 Accessories and Spare Parts

**Table 8-1 Accessory Parts Kit, P/N 101625874, Rev I**

Find No.	Part No.	Quantity	Description
0001	100072235	1	CORD SET ASSEMBLY, ELECTRIC, 230V
0002	353294	1	KEYBOARD SM W/TOUCH PAD BLACK USB
0003	205532	1	LAN UTP CAT 5 PATCH CABLE 4 PAIR RJ45 M/M 25 FEET
0004	101626358	1	FILTER ELEMENT, HIGH PRESSURE, 25 MICRON, 304 WIRE MESH, 3B FILTER
0008	101736752	6	O-RING, SIZE 2-220, COLOR WHITE, 600 DEG F, .139 IN WALL
0009	101623710	6	O-RING, SIZE 2-226, COLOR WHITE, 600 DEG F, ID 1.984 IN X .139 IN WALL
0010	101829179	6	O-RING SIZE 230 VITON <sup>®</sup> 75 DUROMETER 2.484 ID X 0.139 W 400F
0011	204607	6	O-RING 0.209 ID X .070 NITRILE
0012	208940	2	RING BACKUP BOTTOM CELL
0013	208939	2	RING BACKUP TOP CELL
0014	203366	4	BALL 3/16-IN. DIAMETER STAINLESS STEEL
0015	203365	4	VEE JEWEL, CELL ASSEMBLY
0016	100123611	6	SCREW, SET, #6-32 X 3/16, ALLEN, KCP, SS1
0017	204816	1	GREASE HIGH TEMP 3 OZ.
0018	101630287	1	KIT, 3 O-RINGS FOR P8791-HP-40WEV ORING 212V, 138V, AND 138VP
0019	101629342	1	KIT, REPAIR, TESCOM REGULATOR, 30,000 PSIG
0020	203509	2	BOTTLE 16oz CLEAR PET 63mm
0021	207122	1	CALIBRATION FLUID 200 cP 16oz (NIST)
0022	101629340	1	KIT, SOFT GOODS, 30,000 PSIG, TESCOM REGULATOR
0023	210435	1	HIGH TEMPERATURE LUBRICANT 1 OUNCE TUBE
0024	101626628	1	BUSHING, ROTOR, BRONZE
0025	204605	12	O-RING 2 X 1/8 VITON V14 226-75
0026	101531612	12	O-RING 2-220 VITON 75 DUROMETER 400F 1.359 ID X 0.139 W COMPOUND V1475-75
0027	207805	1	HYDRAULIC FLUID 1 QUART BOTTLE
0028	209165	1	TOOL BEARING REMOVAL
0029	203367	5	BUSHING ANGULAR CONTACT



A complete sensor assembly for the 30,000 PSI Tescom regulator is available separately from the Tescom repair kit as PN 101629339.

**Table 8-2 iX77 Rheometer Tool Kit, P/N 101623037, Rev B**

Find No.	Part No.	Quantity	Description
0001	101582697	1	WRENCH, 2.00 INCH, OPEN END AND BOX END
0002	101582698	1	WRENCH, 2.50 INCH, OPEN END AND SOCKET END
0003	205642	1	WRENCH SET ALLEN - SHORT ARM 12-WRENCH SET
0004	101531617	1	ASSEMBLY, CELL FIXTURE
0005	208937	1	TOOL SET
0006	208945	1	TOOL CALIBRATION
0007	101623038	1	WRENCH, OIL FILTER, NYLON STRAP
0008	101629332	1	TOOL, SENSOR TORQUE, 20,000 PSIG AND 30,000 PSIG, TESCOM REGULATOR
0009	206557	1	WRENCH STRAP 5
0010	209165	1	TOOL BEARING REMOVAL

## 9 Parts List

### 9.1 Mechanical Parts

Table 9-1 iX77 Rheometer, P/N 101543382, Rev G

Find No.	Part No.	Quantity	Description
0001	101516396	1	MECHANICAL ASSEMBLY
0002	101531615	1	ELECTRICAL ASSEMBLY
0003	101511610	1	CELL ASSEMBLY
0004	100119204	4	SCREW, SOCKET HEAD CAP, 1/4-20 UNC X 2 1/2, SS
0005	100126628	4	WASHER, LOCK, SPLIT, 1/4 SS, REG
0006	101829179	1	O-RING, 230 VITON 75 DUROMETER 2.484 ID X 0.139 W 400F
0007	101625874	1	ACCESSORY PARTS KIT
0008	101623037	1	TOOL KIT
0009	101630479	1	SOFTWARE
0010	101625591	1	INSTRUCTION MANUAL

**Table 9-2 Mechanical Assembly, P/N 101516396, Rev N**

Find No.	Part No.	Quantity	Description
0001	101514170	1	CHASSIS ASSEMBLY, MECHANICAL
0002	101514171	1	SET, TOWER SHIELD ASSEMBLY
0003	101514172	1	TOWER ROTATIONAL ASSY
0004	101516397	1	MOTOR, AKM BRUSHLESS
0005	390009	1	PUMP, LIQUID, AIR OPERATED, 1:440 RATIO
0006	101516393	1	VALVE, BACK PRESSURE REGULATOR, 30,000 PSI, 1/4 HIGH PRESSURE HYD PORTS
0007	208603	1	ADAPTER 1/4 X 1/8 NPT SPECIAL TAPER SS
0008	101485323	1	ELECTRONIC PRESSURE CONTROLLER, PID, 1/8 NPT INLET PORT, 1/4 NPT CONTROLLED OUTLET PORT
0009	101516394	1	VALVE, HIPCO DIAPHRAGM AIR OPERATED, NORMALLY OPEN, 30000 PSI
0010	101539542	1	FILTER, 17-4PH, 30000 PSI RATED, 1/4 HP PORTS
0011	101539543	1	GAUGE, PANEL MOUNT, 0-35K, SS
0012	101540494	1	TUBING SET, 1/4 HIGH PRESSURE
0013	101542807	2	PORT CONNECTOR SLEEVE
0014	101542806	2	PORT CONNECTOR
0015	100001771	20	GLAND, AUTOCLAVE, ANGLE 40, 60000 POUNDS PER SQ IN, FOR 1/4 TUBE, F250C FEMALE THREAD
0016	100001646	20	COLLAR, AUTOCLAVE, ACL40, 1/4 TUBE, 60000 PSI, SS
0017	385370	2	PLUG, AUTOCLAVE, 1/4, 60000 AP40 PSI, SS
0018	101516024	1	MANIFOLD, 7X HIGH PRESSURE PORTS, 30,000 PSI RATED
0019	101388193	1	SAFETY HEAD, HIGH PRESSURE, RATING- 60K, (F/RUPTURE DISK) INLET- MALE 1/4 HP (HM4) X OUTLET- FEMALE 3/8 NPT
0020	100022028	1	TRANSDUCER, PRESSURE, 30000 PSI
0021	100029496	1	TEE, SS, 60-23HF4, 1/4 TUBE, 60000
0022	101542809	1	RUPTURE DISC, BURST PRESSURE 35000 PSI @ 72 F, 1/4 ANGLED SEAT
0023	101392264	1	60K MALE TO MALE 1/4 HIGH PRESSURE CONNECTOR
0024	101474066	4	MOUNT, VIBRATION, 5/16-18 FEMALE TO MALE
0025	101392263	2	60K BULKHEAD FOR 1/4 F HIGH PRESSURE X 1/4 F HIGH PRESSURE
0026	203509	2	BOTTLE 16OZ CLEAR PET 63MM
0027	203962	2	FILTER INTAKE CAST COVER w/GLASS JAR
0028	101388195	2	ADAPTER, HIGH PRESSURE FITTING, 30K FEM-1/4 NPT X MALE 1/4 HP
0029	100068227	1	PLUG, PIPE, 1/4 NPT MALE PIPE
0030	101485177	1	VALVE, 3 PORT SOLENOID, BODY PORTED, 1/4 INSTANT TUBE FITING (A), 1/4 FNPT (P), 1/8 FNPT (R)
0032	101675112	1	ELECTRO-PNEUMATIC REGULATOR, 0.9 MPA, POWER VOLTAGE 24 VDC, INPUT SIGNAL 0-5 VDC, ANALOG OUTPUT 1-5 VDC, 1/4 PORT, PRESSURE DISPLAY UNIT PSI
0033	101485137	1	FILTER, REGULATOR, MIST SEPARATOR, 1/4 FEMALE NPT, 3/8 INSTANT TUBE AUTO DRAIN
0034	101485740	1	NIPPLE, 1/4 MALE NPT ALL THREAD, 7/8 LENGTH, SS
0035	101485473	1	WATER SEPARATOR, AMG, 1/4 NPT PORTS, 3/8 INSTANT TUBE, WITH AUTO DRAIN, BRACKET

Find No.	Part No.	Quantity	Description
0036	101486208	1	COUPLING, INDUSTRIAL QUICK-DISCONNECT MALE, 1/4 NPT MALE, SS
0037	100126559	1	REGULATOR, NPT 1/4 INCH, 15CFM
0038	101622461	1	VALVE, SOLENOID, DIRECT OPERATED 3 PORT, COMMON, 1/4 FEMALE NPT, 24V DC , 4 MM ORIFICE
0039	100022111	2	CONNECTOR, MALE, STRAIGHT, 1/4 IN SWAGELOC X 1/4 IN NPT PIN, SS
0040	101485082	3	VALVE, SOLENOID, 2 PORT, NC, 1/4 FEMALE NPT, 24V
0042	101485667	2	SILENCER, NAN, GENERAL PURPOSE, NOISE REDUCTION: 35db, 1/4 MALE NPT
0043	101485630	2	SILENCER, NAN(BC SINTERED), GENERAL PURPOSE, NOISE REDUCTION: 16db, 1/8 MALE NPT
0044	208977	75	TUBING 1/4 OD X .035 WALL 304S
0045	101485704	1	ADAPTER, BRANCH UNIVERSAL MALE ELBOW, 1/4 MALE NPT TO 2X 1/4 INSTANT PUSH TUBE
0046	101304411	1	CONNECTOR, MALE, SS, 1/4-IN. O.D. - 1/8-IN. MNPT
0047	120149512	1	ELBOW, SS
0048	101354681	1	ADAPTER, 1/4 SWAGELOK <sup>®</sup> TO 1/4 FEMALE NPT, SS
0049	100032888	2	FAN, INSTRUMENT, 37 CFM, 50/60 HZ, 230VAC
0051	101085670	1	ELB, 90 04T-06 MP SK SS
0052	209372	1	PLATE FAN MOUNTING
0053	209370	3	STANDOFF MALE/FEMALE 0.50 DIA
0054	209371	3	STANDOFF FEMALE 0.50 DIA
0055	209313	1	COVER & BASEPLATE MAGNETOMETER
0056	205059	1	MAGNETOMETER DIGITAL
0057	203782	1	CONNECTOR BRASS D SHELL-9 PIN
0058	101485628	1	FILTER, 3 PORT 1/4 NPT, 10 MICRON
0059	206626	1	PLUG PIPE 1/4 NPT SOCKET HEAD SS
0060	101452507	2	BULKHEAD, PANEL MOUNT, BRASS, 1/4 TUBE
0061	101463369	14	ADAPTER, STRAIGHT, 1/4 MALE NPT TO 1/4 INSTANT TUBE
0062	100023811	9	CONNECTOR, PLASTIC TUBING, 90 DEG, 1/4 TUBE X 1/4 MPT
0063	101463367	1	ADAPTER, TRIPLE ELBOW, 1/4 MALE NPT TO 3X 1/4 INSTANT TUBE
0064	101485749	5	VALVE, CHECK, 1/4 INSTANT PUSH TUBE PORTS
0065	101485744	1	ADAPTER, TRIPLE UNIVERSAL MALE ELBOW, 1/4 MALE NPT TO 3X 3/8 INSTANT PUSH TUBE
0066	101485750	1	ADAPTER, ELBOW, 1/4 FEMALE NPT TO 1/4 INSTANT PUSH TUBE
0067	101543074	1	ADAPTER, BRANCH, 1/4 TUBE, SMC
0068	101452502	1	ADAPTER, ELBOW, BRASS, 3/8 MNPT X 1/4 TUBE
0069	101539546	2	ADAPTER, STRAIGHT, 1/4 MALE NPT, 3/8 TUBE
0070	101543075	1	ADAPTER, ELBOW, 3/8 TUBE TO 1/8 MNPT
0071	101539545	1	ADAPTER, ELBOW, BRANCH, 1/4 MNPT, 2X 3/8 TUBE
0072	101543076	2	TEE, 3/8 TUBE
0073	101543077	2	VALVE, CHECK, 3/8 TUBE
0074	205405	1	TUBING NYLON FLEXIBLE-1/4 IN. OD
0075	101485959	20	TUBING, 1/4 IN O.D. POLYURETHANE, RED
0076	101485964	20	TUBING, 3/8 IN O.D. POLYURETHANE, BLUE
0077	100033128	1	RAIL, MOUNTING, 35MM X 1 M, DIN,46277, SYMMETRICAL
0078	101391619	2	CLAMP, END, UNIVERSAL 35 MM X 7.5 MM MOUNTING RAIL



Find No.	Part No.	Quantity	Description
0079	101483688	10	FEED-THROUGH TERMINAL BLOCKS WITH SPRING-CAGE CONNECTION, CROSS SECTION 0.2 - 2.5 MM, WIDTH 5.2 MM, GRAY
0080	101462159	1	COVER, 2.2MM X 48.5 MM PHOENIX CONTACT 3030417
0081	101543170	1	CONNECTOR, STRAIGHT PLUG WITH CABLE CLAMP, STRAIN RELIEF, SIZE 18, (10) NO. 16 CRIMP PIN CONTACT
0082	101543171	1	CONNECTOR, STRAIGHT PLUG, 10 CONTACTS CRIMP TYPE
0083	101227915	2	CABLE, CLAMP, BOOT INCLUDED, SHELL SIZE 18
0084	100072391	2	PANEL, SINGLE CIRCUIT, THERMOCOUPLE JX CALIBRATION
0085	208447	180	CABLE CONTROL SINGLE PAIR 22 A
0086	101462041	3	FEED THRU, COMBICON/PHOENIX CONTACT 1852163
0087	101461990	3	PLUG, COMBICON/PHOENIX CONTACT 1825640
0088	101543172	1	CABLE, POWER, KOLLMORGEN, 3FT, FOR S200 SERVO
0089	101543173	1	CABLE, FEEDBACK, KOLLMORGEN, FOR S200 SERVO, 3FT
0091	206257	24	WIRE 14 AWG PVC STRANDED RED
0092	208527	20	WIRE 18 AWG PVC STRANDED BLUE
0093	208550	10	CABLE 22 AWG SHIELDED 2 PAIR
0094	208477	10	TUBE HEAT SHRINK 3/8 DIA RED
0095	208478	7	TUBE HEAT SHRINK 1/8 DIA CLR
0096	204606	1	O-RING 2-367 NEOPRENE 70 DUROMETER
0097	101251844	8	SCREW, 6-32 x 1 3/4, SOCKET HEAD, SS
0098	101260744	2	SCREW, MACHINE, PAN HEAD, PHILLIPS 4-40 UNC x 0.1875, SS
0099	207771	4	6-32 X 3/16 BHMS SS
0100	101260792	10	SCREW, MACHINE, PAN HEAD, PHILLIPS, 6-32 UNC x 0.25, SS
0101	395848	31	SCREW - HEX SOC - 10-32 NF X .50 - SS
0102	207633	4	NUT 10-32 HEX REGULAR SS
0103	100123799	3	SCREW, CAP, SOCKET HEAD, #10-32 UNF X 1, SS
0104	100112075	4	SCREW, SOCKET HEAD CAP, #10-32 UNF X 1 1/2, HEX SOCKET
0105	100123951	4	SCREW, MACHINE 5/16-18 X 1/4 SOCKET, CAP, ALN SS1
0107	100123983	5	SCREW, CAP SOCKET HEAD, 3/8-16 NC X 1 1/4, SS, ALLEN
0108	101543175	4	SCREW, 3/8-24 X 5/8, SS, SOCKET HEAD CAP
0109	100123510	2	SCREW, CAP, SOCKET HEAD, #4-40 UNC X 1, SS
0110	382649	2	SCREW - HEX SOC - 1/4-20NC X 1/2 - SS
0111	100123897	6	SCREW, CAP, SOCKET HEAD, 1/4-20 X 5/8 SS
0112	100161058	6	SCREW, CAP, SOCKET HEAD, #1/4-20 NC X 1/4 SS
0113	100020616	1	ELBOW, ADAPTER, TUBE, SWAGELOK <sup>®</sup> 1/4 TUBE, 1/8 MNPT, SS
0114	101540491	1	VALVE, AIR FLOW CONTROL, 1/4 FNPT, 2000PSI
0115	100123797	2	SCREW, CAP, SOCKET HEAD, #10-32 UNF X 1/4 SS
0116	101260903	2	SCREW, MACHINE, PAN HEAD, PHILLIPS, 0.25 DIA -20 UNC x 0.375, SS
0117	101470447	3	ADAPTER, STRAIGHT, 1/4 FEMALE NPT BULKHEAD TO 1/4 INSTANT TUBE
0118	204056	1	BULKHEAD FEMALE 1/4T X 1/4FNPT
0119	347556	1	TEE, 1/4 NPT
0120	101683863	1	MOUNTING BRACKET WITH NUT FOR AIR REGULATOR
0121	205728	2	CLIP LARGE
0122	101265322	2	SCREW, THREADED, CAP, SOC HEAD (US) - NO. 8 -32 UNC
0123	101486173	2	SCREW, CAP, SOCKET HEAD, 5/16-18 X 4, SS

Find No.	Part No.	Quantity	Description
0124	208602	1	GAUGE 160 PSI 1.5in DIAL 1/8 BOTTOM CONN
0125	120147184	1	ELBOW MALE SS
0126	101543078	1	ADAPTER, ELBOW, 3/8 TUBE TO 1/4 MNPT
0127	204923	1	RETAINER RING, 8.419 DIA X .187 THK X .418 WALL, SPRING STEEL OIL DIPPED FINISH, RAMSEY RRN-800
0128	204922	3	RETAINER EXTERNAL E 3/8 TRUARC 5133
0129	207815	1	WASHER 5/8 X .385 X .062 NYLON
0130	209359	1	LABEL SET-FLUID RESERVOIR
0131	204607	2	O-RING 0.209 ID X .070 NITRILE
0132	101887617	9	PIN CONTACT CRIMP, CONNECTOR COMPONENT, GOLD PLATED, SIZE 16, 16-22 AWG WIRE
0133	101887618	9	SOCKET CONTACT CRIMP, CONNECTOR COMPONENT, GOLD PLATED, SIZE 16, 16-22 AWG WIRE
0134	208528	15	WIRE 18 AWG PVC STRANDED GRAY
0135	208550	15	CABLE 22 AWG SHIELDED 2 PAIR
0136	101483692	5	MULTI CONDUCTOR, 12 COND, 22AWG STRAND (7X30), PVC, CONTROL/INSTRUMENT/COMPUTER
0143	204076	4	INSULATION RUBBER TUBE 3/8in. ID
0144	101893838	1	KIT,CELL HOLD DOWN CLAMP ASSY

**Table 9-3 iX77 Chassis Assembly, Mechanical, P/N 101514170, Rev J**

Find No.	Part No.	Quantity	Description
0001	101513365	1	BOTTOM FAB FRAME
0002	101540490	1	TOP COVER, RIGHT, MECHANICAL,
0003	101513368	1	TOP COVER, LEFT, MECHANICAL
0004	101513360	1	BASE PLATE, BOTTOM FAB ASSY
0005	101513367	1	GAUGE MOUNT
0006	101472339	1	BRACKET, HIGH PRESSURE FILTER
0007	101472341	1	MOUNTING BRACKET, FILTER / SEPARATOR
0008	101513366	1	OILER DRAWER
0009	101514168	1	FRONT COVER, BOTTOM FAB ASSY
0010	101513369	1	MOUNT, HIGH PRESSURE MANIFOLD
0011	101516027	1	MOUNTING BLOCK, FLUSH VALVE
0012	101481469	1	LOCKING TAB, BASE PLATE
0013	100123802	13	SCREW, CAP, SOCKET HEAD, 10-32 UNF X 1/2, SS
0014	100112806	24	SCREW, SOCKET HEAD CAP, #10-32 UNF X 3/8, SS, HEX SOCKET
0015	100123799	2	SCREW, CAP, SOCKET HEAD, #10-32 UNF X 1, SS
0016	101260861	21	SCREW, MACHINE, PAN HEAD, PHILLIPS, 10-32 UNF x 0.25, SS
0017	100126545	12	WASHER, FLAT, NO. 10, SS, 0.5 OD X 0.219 ID X 0.049 THK
0018	100123766	7	WASHER, LOCK, INTERNAL TOOTH, #10 SS
0019	100123963	4	NUT, HEX, 3/8-16, SS
0020	101497192	1	SCREW, SHOULDER 5/16 DIA X 3/4 LG X 1/4-20UNC THD SS
0021	101514169	1	ELECTRICAL MANIFOLD
0022	101265316	4	SCREW, THREADED, CAP, SOC HEAD (US) - NO. 8 -32 UNC x

Find No.	Part No.	Quantity	Description
			0.25 - 18-8 SS
0023	101540493	1	BRACKET, TOWER, MECHANICAL ASSY
0024	102246060	1	BACK COVER

**Table 9-4 iX77, Tower Rotational Assembly, P/N 101514172, Rev. E**

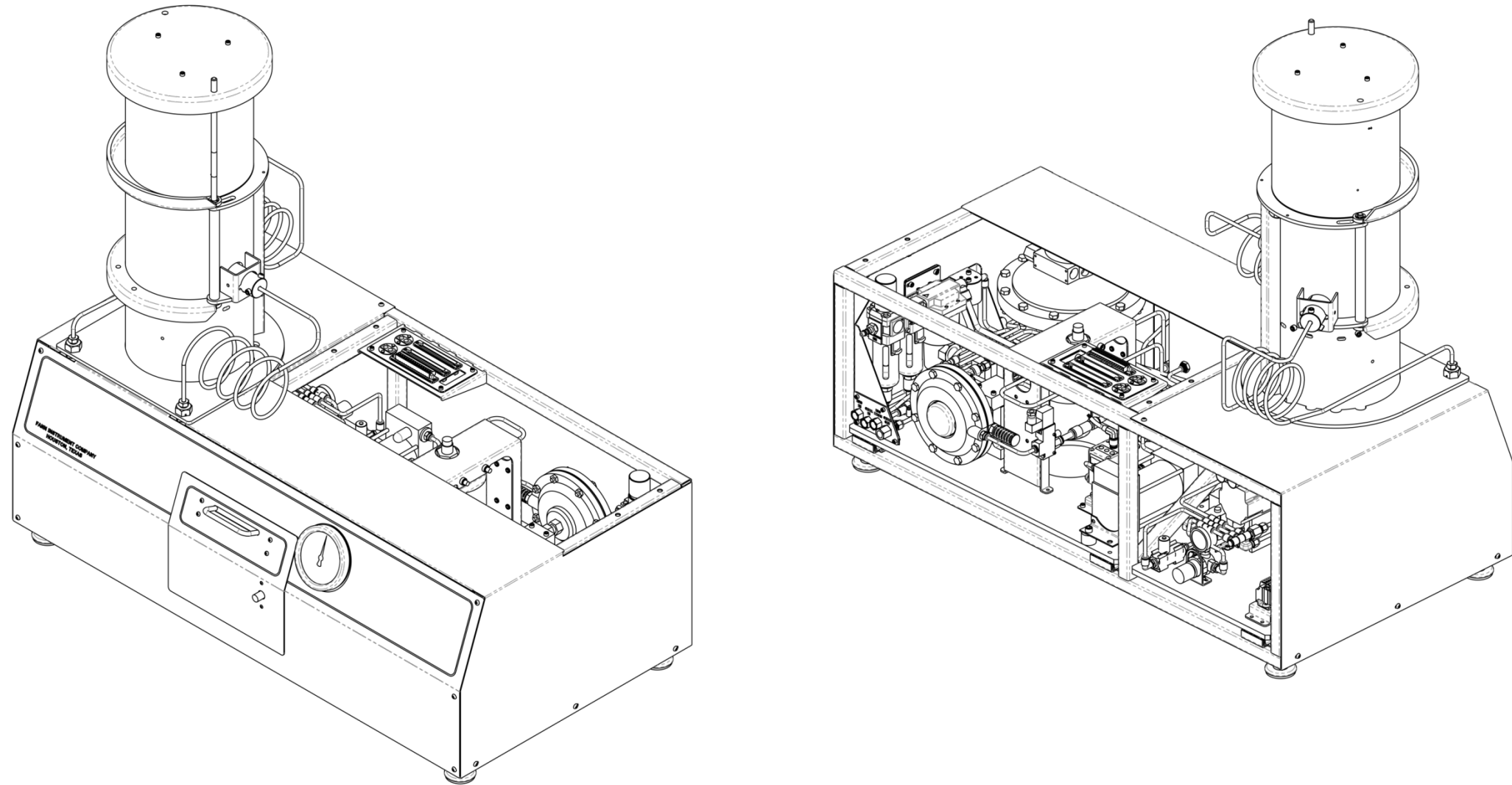
Find No.	Part No.	Quantity	Description
0001	101514828	1	HOT WELL ASSEMBLY
0002	101516026	1	DRIVE CAN ASSEMBLY
0003	101514826	3	SUPPORT LEG, ROTATIONAL ASSEMBLY
0004	101516023	1	ANCHOR PLATE, DRIVE ASSEMBLY
0005	101514829	1	DRAIN COVER, DRIVE ASSEMBLY,
0006	101519468	1	GEARBOX, GAM DYNA RIGHT ANGLE, HOLLOW OUTPUT SHAFT, RATIO 10:1
0007	101519469	1	TEE, 1/8 FEMALE NPT
0008	101543297	1	ADAPTER, THERMOCOUPLE MOUNT
0009	203988	1	CONNECTOR BULKHEAD 1/8TUBE X 1/8FNPT
0010	204026	1	TUBING 316 SS OR 304 SS, 0.125 IN. OD X .069 IN. ID 9,750 PSI
0011	101504984	1	ADAPTER, 1/8 TUBE X 1/16 MNPT, 316SS
0012	101511602	1	THERMOCOUPLE,TYPE J, 1/8 SS SHEATH, 13.25 LG, 36.00 FLEX LEADS
0013	205388	1	HEATER CYLINDER 750 WATT 115
0014	208916	1	HEATER COVER
0015	382649	6	SCREW - HEX SOC - 1/4-20NC X 1/2 - SS
0016	100123899	4	SCREW, CAP, SOCKET HEAD, 1/4-20 NC X 3/4, SS
0017	205294	1	ADHESIVE HI-TEMP CERAMIC 16 OZ
0018	205295	16	WIRE 28 AWG ST STEEL SOLID .016
0019	100020616	1	ELBOW, ADAPTER, TUBE, SS

**Table 9-5 iX77, Drive Can Assembly, P/N 101516026, Rev E**

Find No.	Part No.	Quantity	Description
0001	101770520	1	iX77 DRIVE CAN SET W/ INSULATOR SET AND HARDWARE
0008	205055	1	MAGNET RING
0009	205294	1	ADHESIVE HI-TEMP CERAMIC 16 OZ

Table 9-6 iX77, Drive Can Set, P/N 101543354, Rev A

Find No.	Part No.	Quantity	Description
0001	101519371	1	DRIVE CAN
0002	101514825	1	FLANGE, ROTATIONAL ASSEMBLY
0003	101514827	1	DRIVE SHAFT, ROTATIONAL ASSEMBLY
0004	101519372	1	MAGNETIC SHIELD RETAINER, DRIVE CAN
0005	101519373	1	INNER MAGNETIC SHIELD
0006	101519374	1	OUTER MAGNETIC DRIVE SHIELD, DRIVE CAN
0007	100123709	6	SCREW, CAP, SOCKET HEAD, #8-32 UNC X 3/8 SS
0008	120127922	6	SCREW 8-32X3/16 SOCHD CAP SS 92196A189
0009	207858	3	6-32 X 1/4 HSSS BOPL



**Figure 9-1 iX77 Mechanical Assembly, Front & Back View, Rev J**

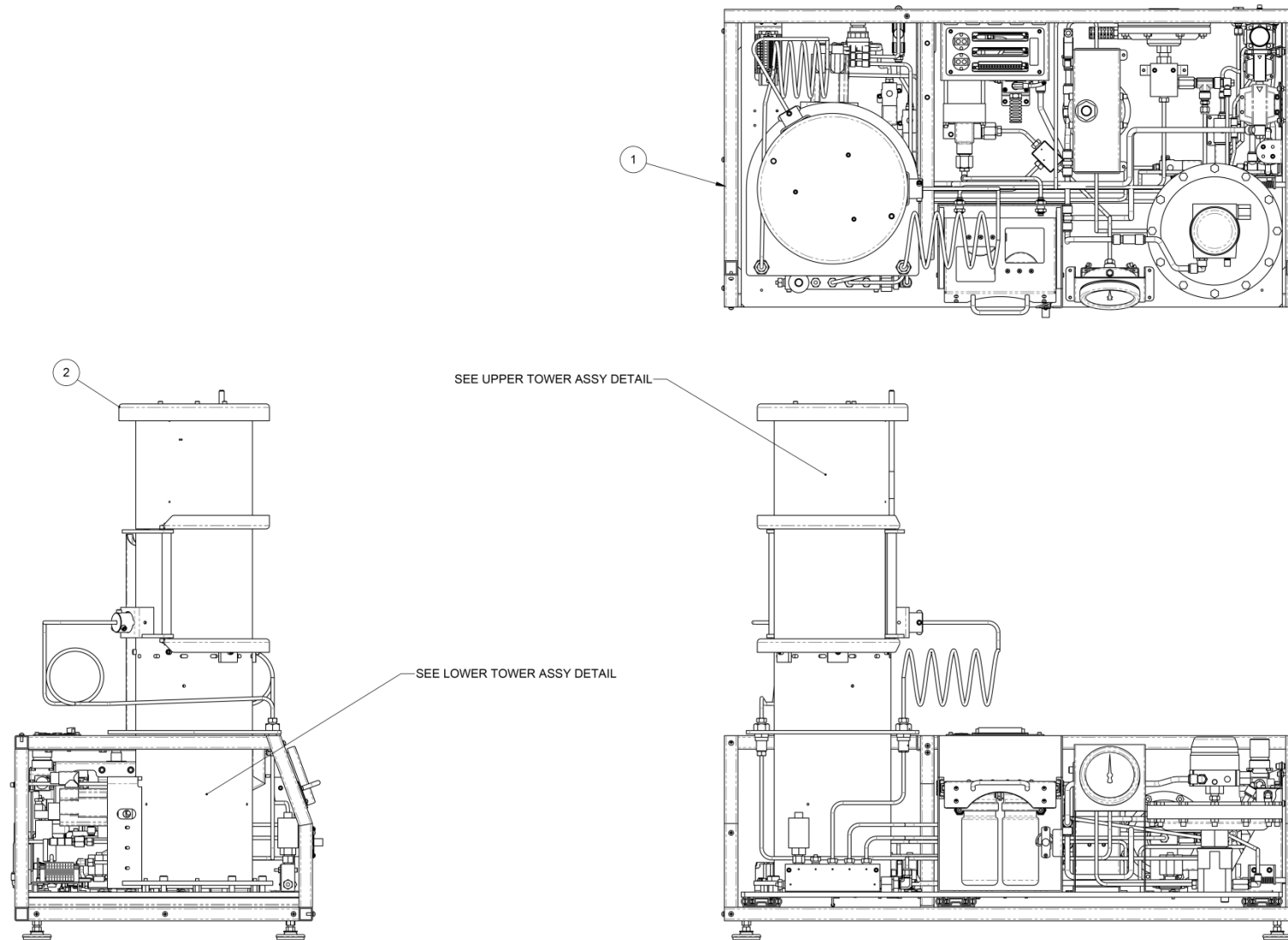


Figure 9-2 iX77 Mechanical Assembly, Inside View, Rev J

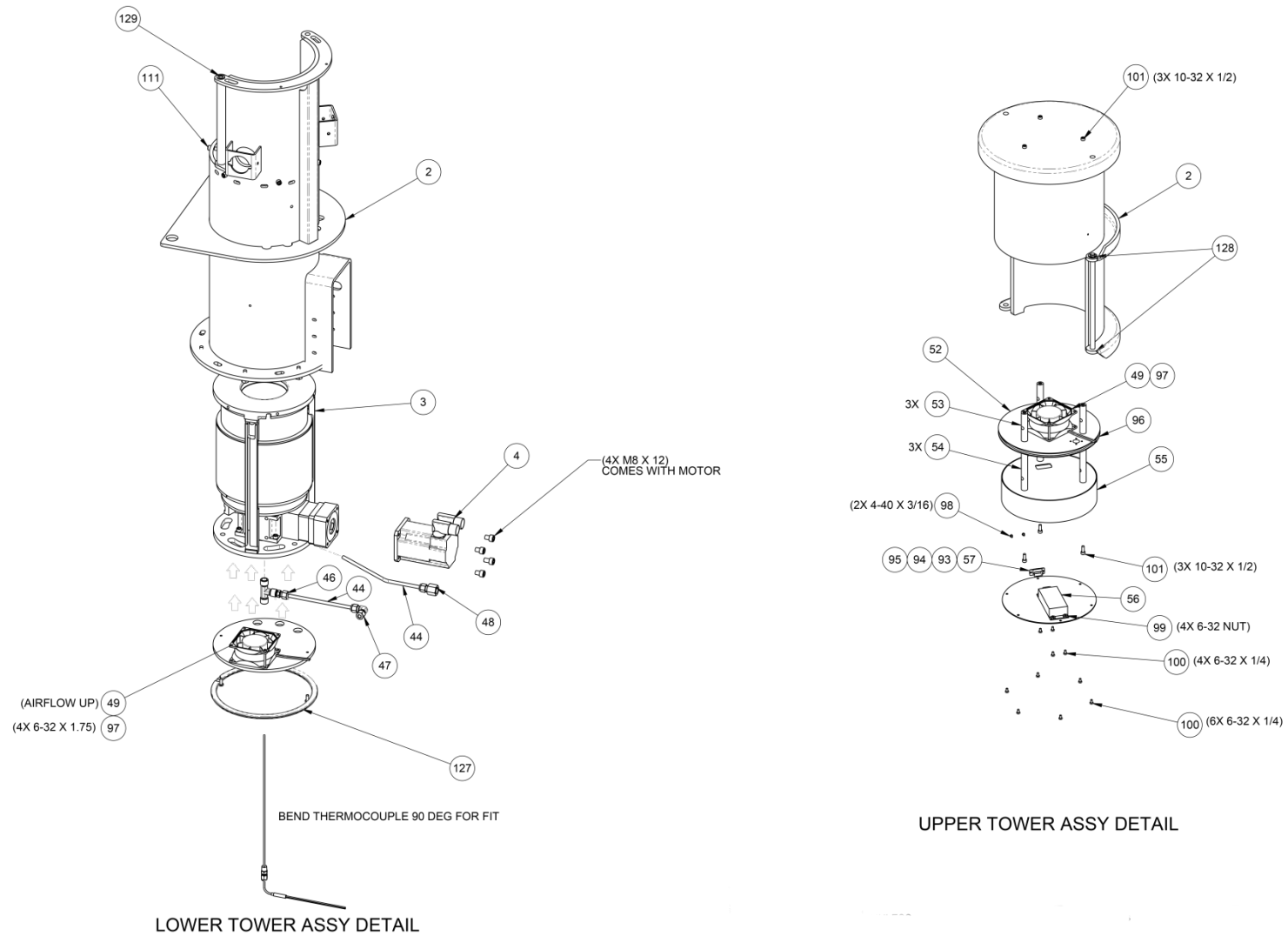


Figure 9-3 iX77 Mechanical, Tower Assembly, Rev J

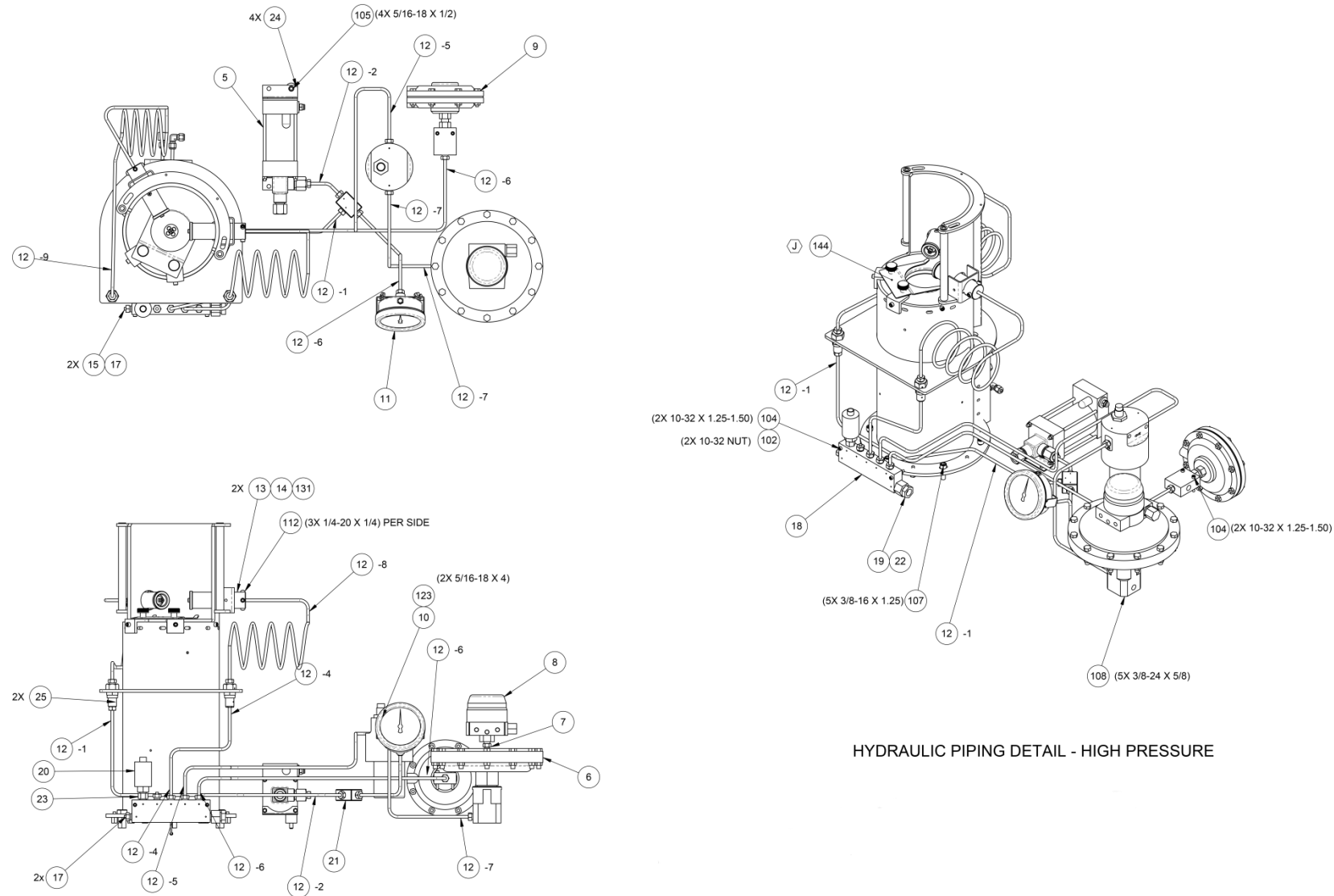


Figure 9-4 iX77 Mechanical, Hydraulic Piping, High Pressure, Rev J



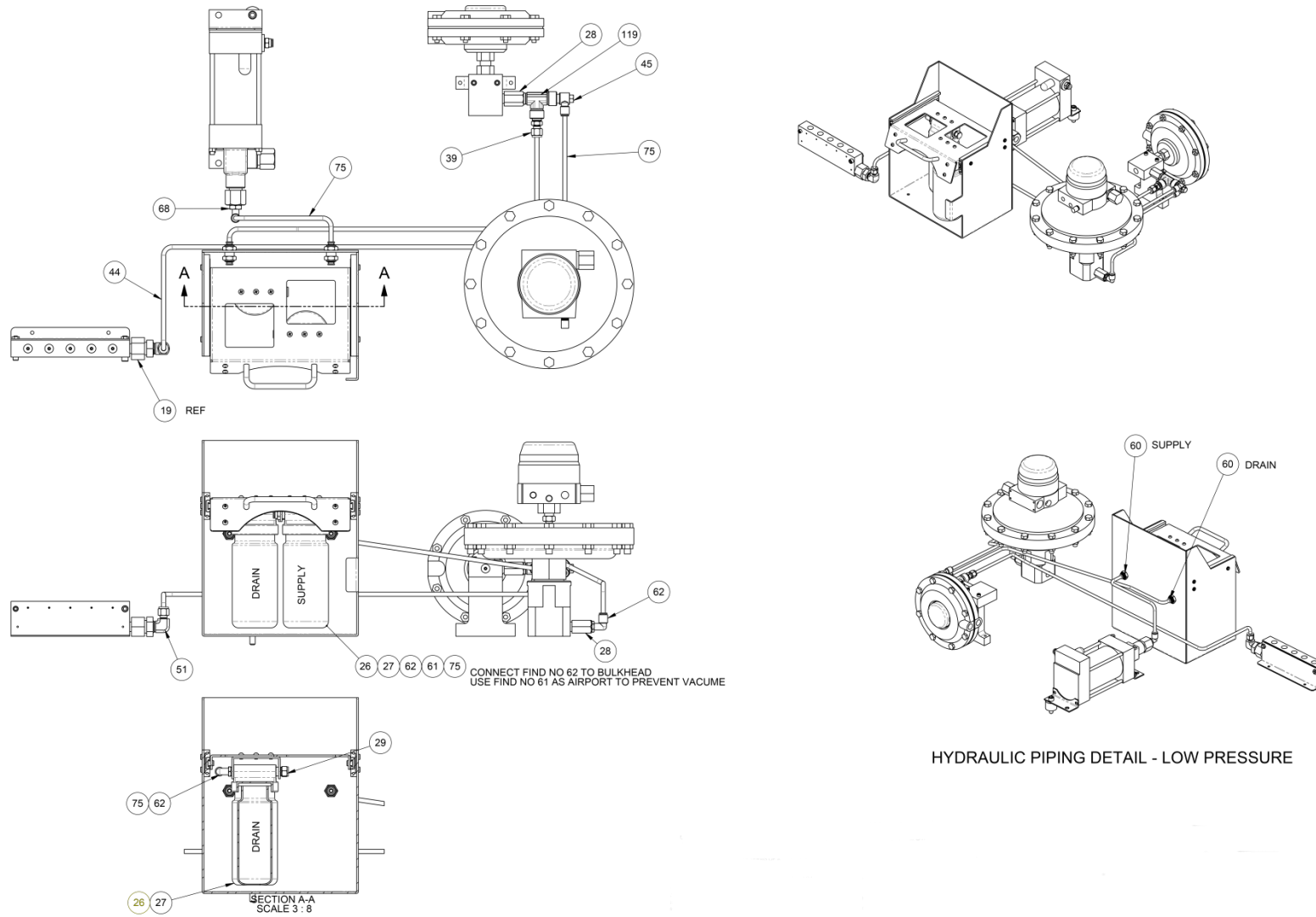
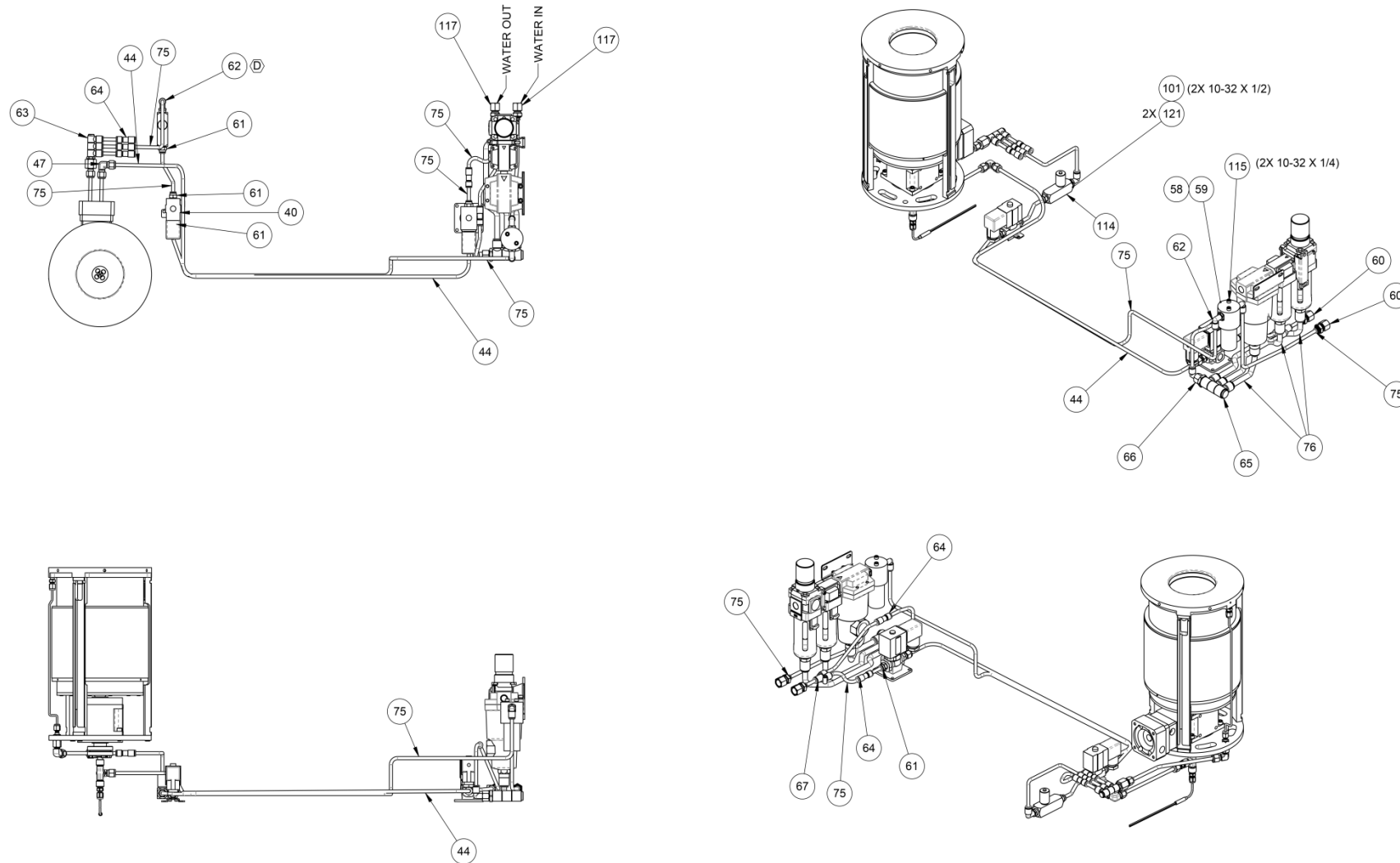
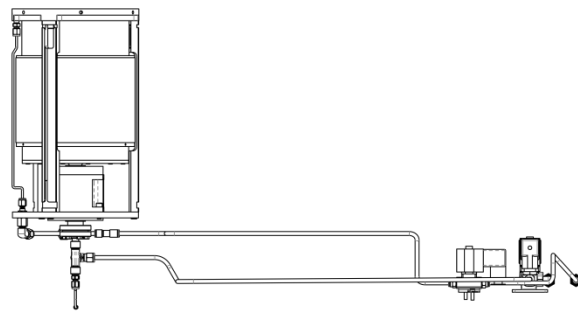
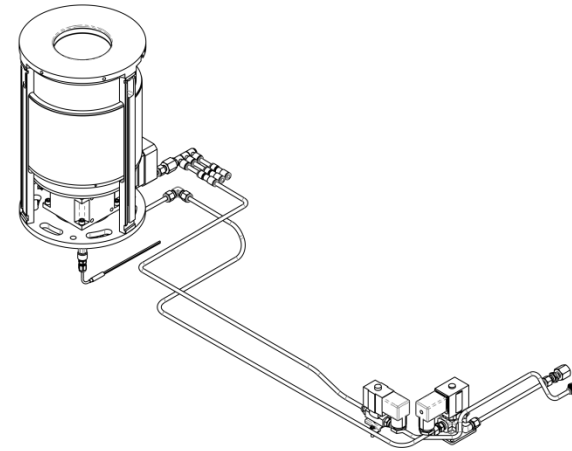
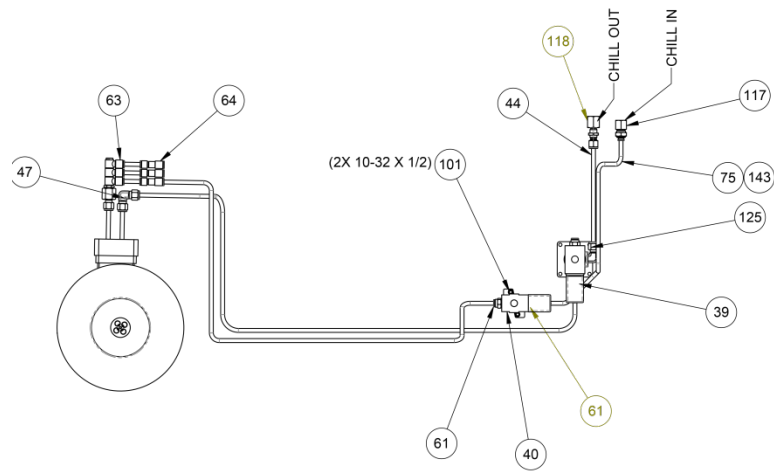


Figure 9-5 iX77 Mechanical, Hydraulic Piping, Low Pressure, Rev J



WATER PIPING DETAIL

Figure 9-6 iX77 Mechanical, Water Piping, Rev J



CHILLER PIPING DETAIL

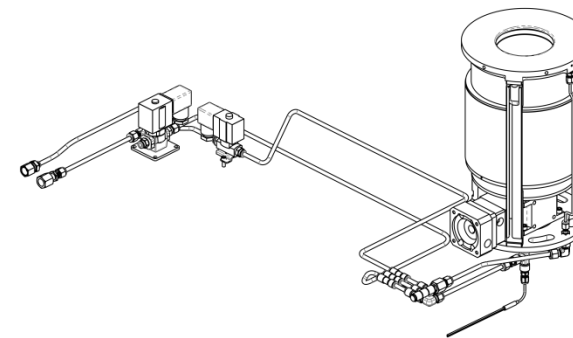


Figure 9-7 iX77 Mechanical, Chiller Piping, Rev J

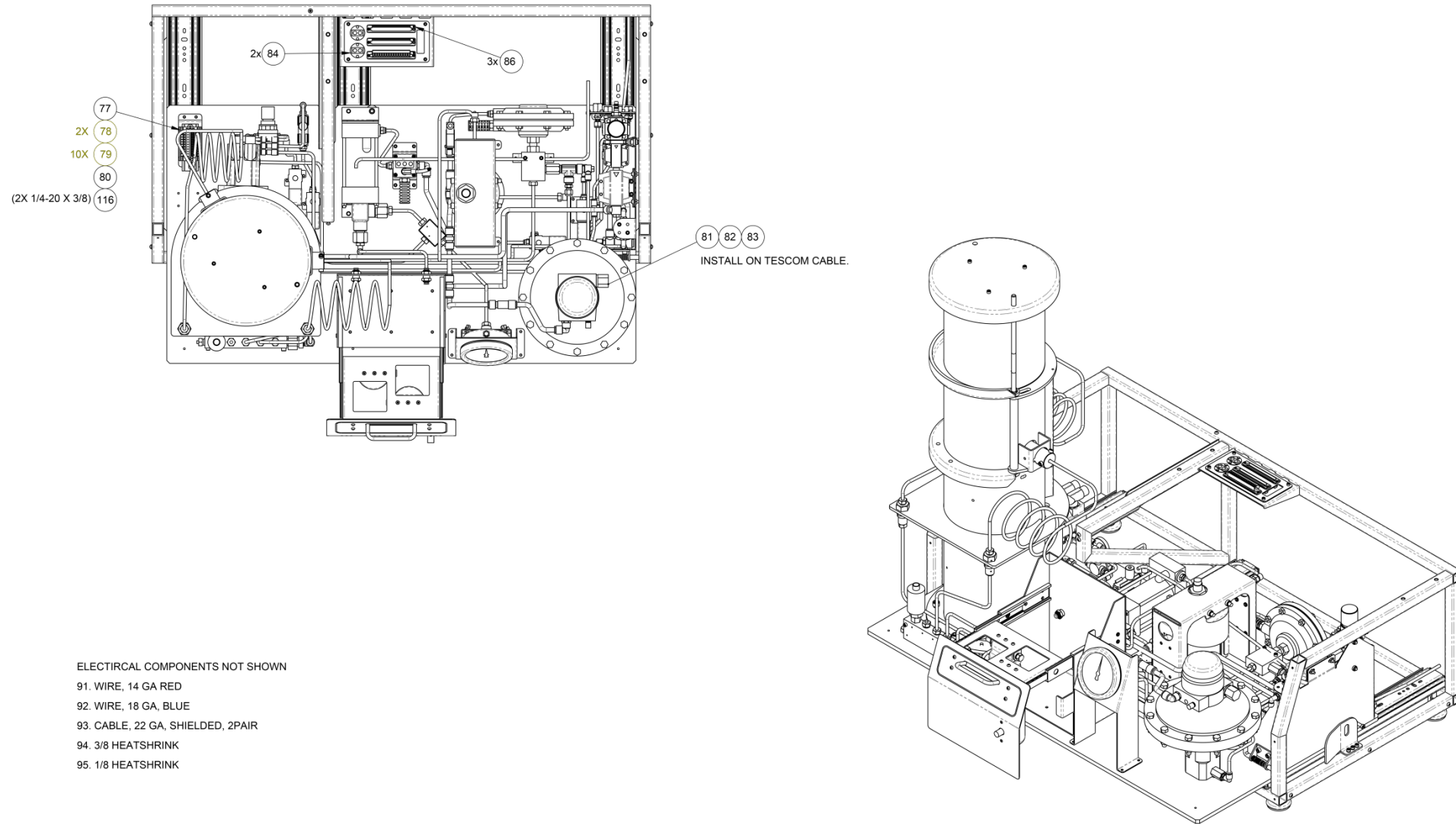


Figure 9-8 iX77 Mechanical, Electrical Components, Rev J

**9.2 Electrical Parts**

**Table 9-7 iX77 Electrical Assembly, P/N 101531615, Rev M**

Find No.	Part No.	Quantity	Description
0001	101531616	1	TOP FAB ASSEMBLY
0002	102044894	1	PC, PANEL MOUNT, 15 IN TFT XGA, 1.4 GHZ PENTIUM M, 1 GIG RAM, 1 PCI SLOT, WINDOWS XP
0003	101462088	1	DATA ACQUISITION SYSTEM, 8-SLOT CHASSIS FOR COMPACT DAQ NI cDAQ-9172
0004	101462492	1	POWER SUPPLY, 10-15 V DC
0005	101471629	1	DIN RAIL POWER SUPPLY UNIT 24 V DC/2 A
0007	101483687	1	RELAY - WATCH DOG TIME DELAY, CONTROL SWITCH TRIGGER 240 VAC.
0008	101462535	1	RELAY SOCKET
0009	101468850	1	OPTOCOUPLER RELAY ASSEMBLY
0010	101483688	26	FEED-THROUGH TERMINAL BLOCKS WITH SPRING-CAGE CONNECTION
0012	101391619	7	CLAMP, END, UNIVERSAL, FOR 35 MM X 7.5 MM MOUNTING RAIL
0014	204400	1	GUARD FAN FINGER 3 1/8-IN. f/80MM METAL
0015	101483693	1	FAN, 24 VDC 3.2 x 3.2 x 1 IN (80x80x25 MM, 42 CFM
0016	101511601	1	SERVO DRIVE, S200 SERIES
0017	101449357	2	SOLID STATE RELAY 20 AMP DIN MOUNT DC CONTROL
0018	101504490	1	COUPLER KIT, PANEL MOUNT, NETWORK CABLE
0019	100031587	1	INLET, ELECTRICAL, FLANGED, 3 WIRE, 20 AMP, 250 VAC, TWIST LOCK,
0020	101481464	3	EXTENSION - USB CABLE ASSEMBLY, PANEL MOUNT
0021	101471634	1	THERMAL CIRCUIT BREAKER, 15A, DPST, ROCKER, WITH UNDERVOLTAGE
0023	101727314	1	SWITCH, EMERGENCY-STOP
0024	101471636	1	LEGEND PLATE, FOR E-STOP SWITCH, 60 MM DIAMETER, EMERGENCY STOP MARKINGS
0026	101462060	1	ANALOG OUTPUT MODULE NI cRIO-9263
0027	101462057	2	DIGITAL OUTPUT AND RELAY MODULE NI cRIO-9472
0028	101462058	1	ANALOG INPUT MODULE NI cRIO-9215
0029	101462062	1	DIGITAL INPUT AND COUNTER/TIMER MODULE NI cRIO-9401
0030	101462045	1	ANALOG INPUT MODULE NI cRIO9211
0031	120166918	1	CONN DB25 FEMALE SOLDER CUP
0032	203782	1	CONNECTOR BRASS D SHELL-9 PIN
0033	101504488	1	CABLE, DATA TRANSMISSION, CATEGORY 6, 5 FT
0034	100025404	1	HANDLE, INSTRUMENT, 3/8 IN DIA
0035	101462159	2	COVER, 2.2MM X 48.5 MM
0036	101483689	20	PLUG-IN BRIDGE FOR CROSS-CONNECTIONS IN THE TERMINAL CENTER
0037	101260861	8	SCREW, MACHINE, PAN HEAD, PHILLIPS, 10-32 UNF x 0.25, SS
0038	101260754	2	SCREW, MACHINE, PAN HEAD, PHILLIPS, 4-40 UNC x 0.50, SS
0039	101260792	3	SCREW, MACHINE, PAN HEAD, PHILLIPS, 6-32 UNC x 0.25, SS
0040	101260869	2	SCREW, MACHINE, PAN HEAD, PHILLIPS, 10-32 UNF x 0.75, SS
0041	101567523	1	POWER SUPPLY, 24 V DC/4A, DIN MOUNT
0042	101361749	2	SCREW, MACHINE, PAN HEAD, PHILLIPS, 10-32 UNF x 0.375

Find No.	Part No.	Quantity	Description
			LENGTH, SS
0043	101260649	4	SCREW, MACHINE, PAN HEAD, PHILLIPS, 6-32 UNC x 1.50, SS
0044	100110391	4	SCREW, MACHINE, PAN HEAD, PHILLIPS, #8-32 X 1/4, SS
0045	101260796	4	SCREW, MACHINE, PAN HEAD, PHILLIPS, 6-32 UNC x 0.375, SS
0046	207632	4	NUT 6-32 HEX REGULAR, SS
0047	208527	36	WIRE 18 AWG PVC STRANDED BLUE
0048	206257	191	WIRE 14 AWG PVC STRANDED RED
0049	101580642	1	USB 1.1 AND 2 HUB 4 PORT WITH 1 METER USB CABLE
0050	101635103	3	3M VHB FOAM TAPE, ADHESIVE BOTH SIDES, 4950, 0.045 IN THK x 1 IN WIDE, WHITE
0051	101634933	2	RAIL ADAPTER, DIN, GRAY
0052	207871	8	WASHER FLAT 10 SS
0054	101634351	3	SPRING CAGE GROUND TERMINAL BLOCK, AWG 24 TO 14, YELLOW GREEN
0056	101443930	1	BASE, 5 PIN SOCKET, FINGER SAFE, DIN/PANEL MOUNT
0057	101443931	1	RELAY, ICE CUBE, 220-240VAC, 20 AMP
0058	101443932	1	CLIP, RELAY, ICE CUDE, 220-240VAC, 20 AMP
0059	101451384	1	RELAY, TWO POLE, 30 AMP, 220/240 VAC, PANEL MOUNT
0060	101726696	1	TEMPERATURE LIMIT SWITCH
0061	101309174	1	RELAY,24VDC,WITH BASE
0067	101260665	2	SCREW, MACHINE, PAN HEAD, PHILLIPS, 8-32 UNC x 0.375, SS
0068	208085	1	RESISTOR 4.99K OHM
0069	101736419	1	MALE CONNECTOR, 4 POLE, 5MM PIN SPACING, 12 A
0070	101736420	1	FEMALE CONNECTOR, 4 POLE, 5MM PIN SPACING, 12 A
0071	100033128	1	RAIL, MOUNTING, 35MM, X 2 M, DIN, 46277, SYMMETRICAL
0072	100033128	1	RAIL, MOUNTING, 35MM, X 2 M, DIN, 46277, SYMMETRICAL
0073	100033128	1	RAIL, MOUNTING, 35MM, X 2 M, DIN, 46277, SYMMETRICAL
0074	100033128	1	RAIL, MOUNTING, 35MM, X 2 M, DIN, 46277, SYMMETRICAL
0075	101581263	2	BUSHING, NEOPRENE, THERMOCOUPLE
0078	349301	6	TERMINAL FEMALE Q.C,.25X.032 12-10GA NYLON FULLY INSULATED FEMALE DISCONNECT WIRE RANG 12/10 AWG TAB SIZE .250 X .032 25 PER PACKAGE
0079	100032008	4	TERMINAL, FEMALE, SLIP ON, FULLY INSULATED, FOR #10-12 GA WIRE
0080	100031673	2	CONNECTOR, PLUG, THERMOCOUPLE
0081	101461967	3	PLUG, COMBICON
0082	101967224	1	CONNECTOR,DB9 MALE/FEMALE, PANEL MOUNT
0084	101967226	2	JACKSCREW, 4-40 STANDOFF
0085	101832017	1	1 FT USB TO RS232 DB9 SERIAL ADAPTER CABLE
0086	101543174	1	KIT, CONNECTOR
0087	205379	3	GROMMET EDGE .062-.099 THK SLD
0088	204331	1	BUTT SPLICE 16-14 AWG INSULATED
0089	208457	2	BUTT SPLICE 2RA-18
0090	207769	4	4-40 X 3/16 BHMS SS
0091	100028695	6	SCREW, FLAT HEAD, MACHINE, #4-40 NC X 1/2, BRASS, NICKEL PLATED
0092	206217	48	WIRE 20 AWG PVC STRANDED RED
0093	206219	48	WIRE 20 AWG PVC STRANDED BLACK
0094	208485	144	WIRE THERMOCOUPLE DUPLEX TYPE
0095	208521	5	WIRE 18 AWG PVC STRANDED BROWN

Find No.	Part No.	Quantity	Description
0096	208523	55	WIRE 18 AWG PVC STRANDED RED
0097	208525	4	WIRE 18 AWG PVC STRANDED YELLOW
0098	208526	2	WIRE 18 AWG PVC STRANDED GREEN
0099	208529	4	WIRE 18 AWG PVC STRANDED WHITE
0100	101483695	36	WIRE, HOOK UP, 14AWG, STRANDED, PVC, 600V, UL 1015 DARK GREEN
0101	203857	100	FERRULE INSUL 18 AWG WIRE
0102	102004681	30	FERRULE, 14AWG, BLUE, HI-2.5/14, 0.31IN, 0.55IN, 0.31IN L X 0.1IN DIA
0103	102004682	20	INSULATED WIRE FERRULES (SIZE 1 MM) YELLOW 18 AWG
0104	102004685	4	FERRULE, INSULATED WIRE, BLUE, 14 AWG, 2.5 MM2

**Table 9-8 iX77 Top Fab Assembly, P/N 101531616, Rev D**

Find No.	Part No.	Quantity	Description
0001	101513362	1	TOP FRAME ASSY
0002	101513361	1	TOP COVER ASSY
0003	101513363	1	FACE PLATE ASSY
0004	101471463	1	HINGE, FACE PLATE
0005	101471461	1	HINGE MOUNT
0006	101471464	1	COVER, FILTER
0007	101481462	1	FILTER, INTAKE, SA UCA, 6.5 X 6.5 X .38 THK 60 PPI GRAY
0009	101260861	6	SCREW, MACHINE, PAN HEAD, PHILLIPS, 10-32 UNF x 0.25, SS
0010	100126545	6	WASHER, FLAT, NO. 10, SS, 0.5 OD X 0.219 ID X 0.049 THK

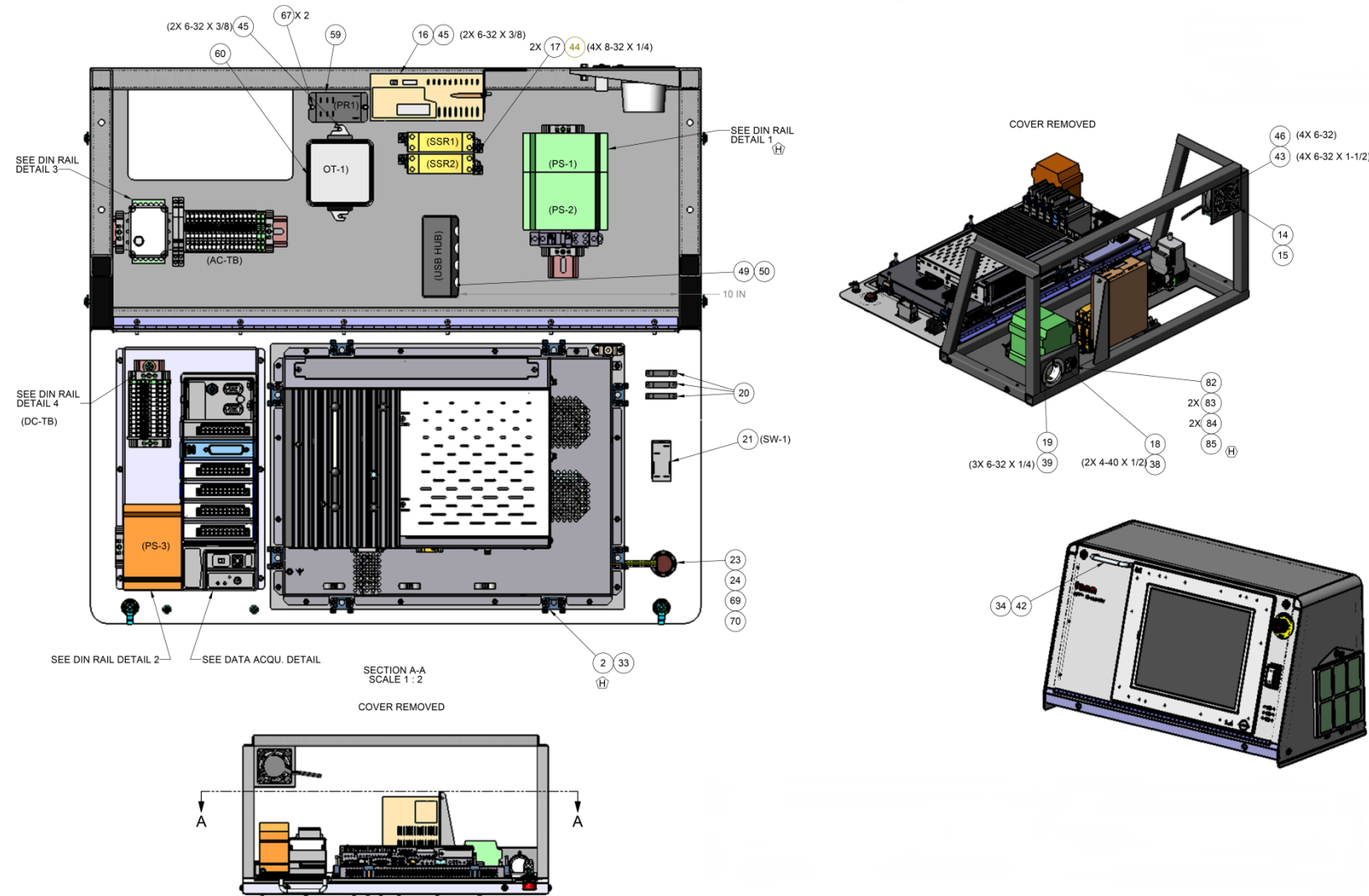


Figure 9-9 iX77 Electrical Assembly, Main Components, Rev H



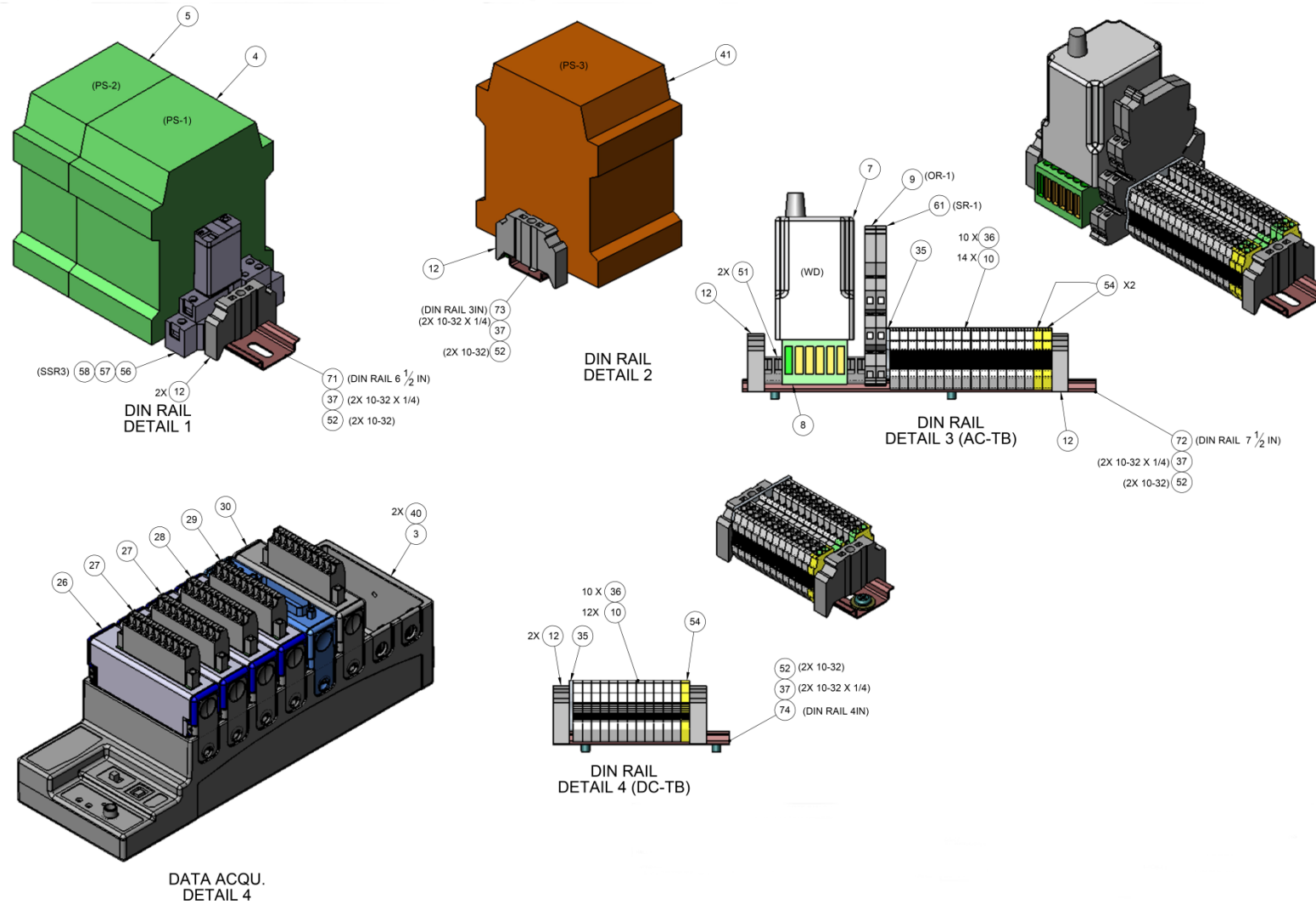


Figure 9-10 iX77 Electrical Assembly, Din Rail Components, Rev H

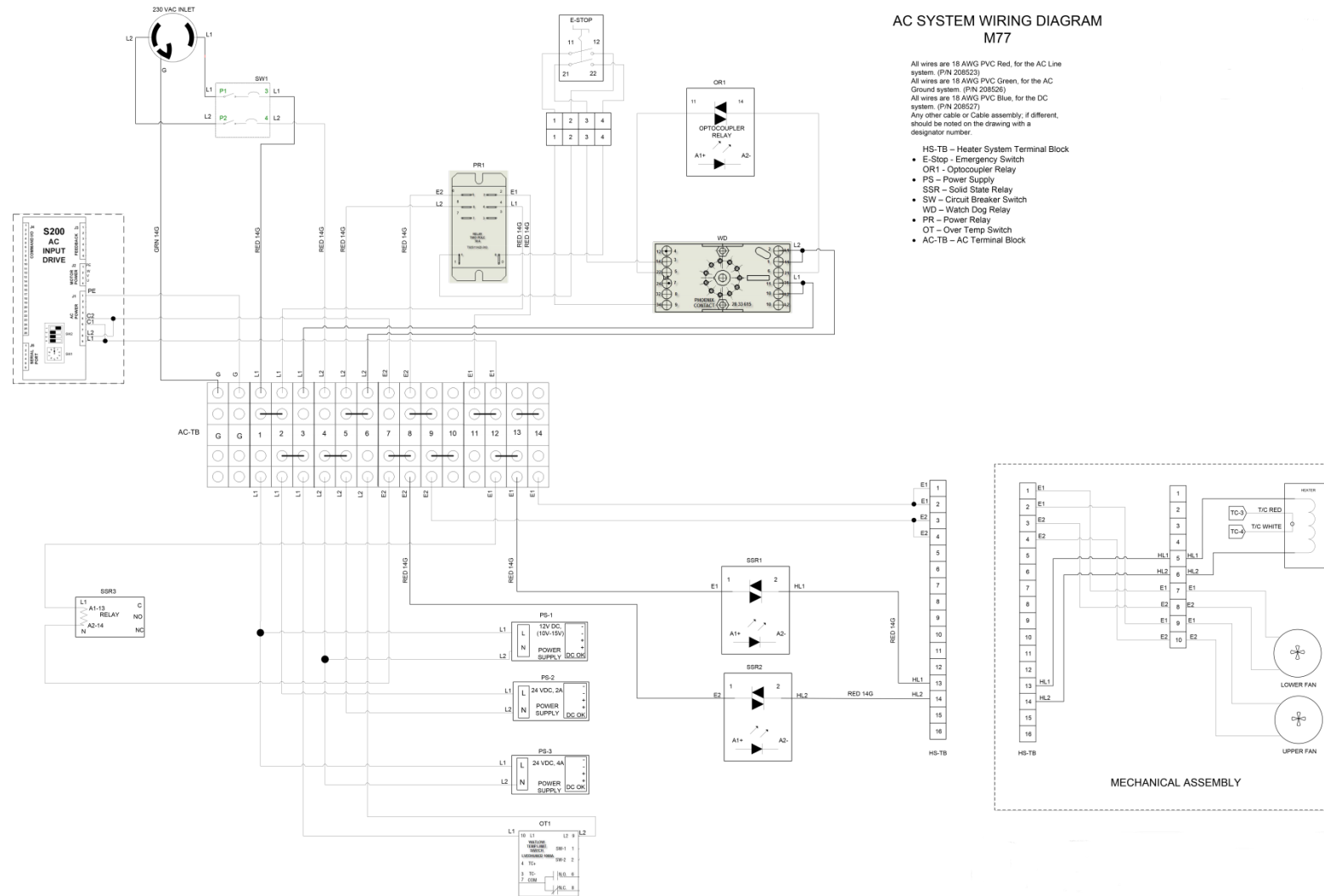


Figure 9-11 iX77 AC System Wiring Diagram, Rev J

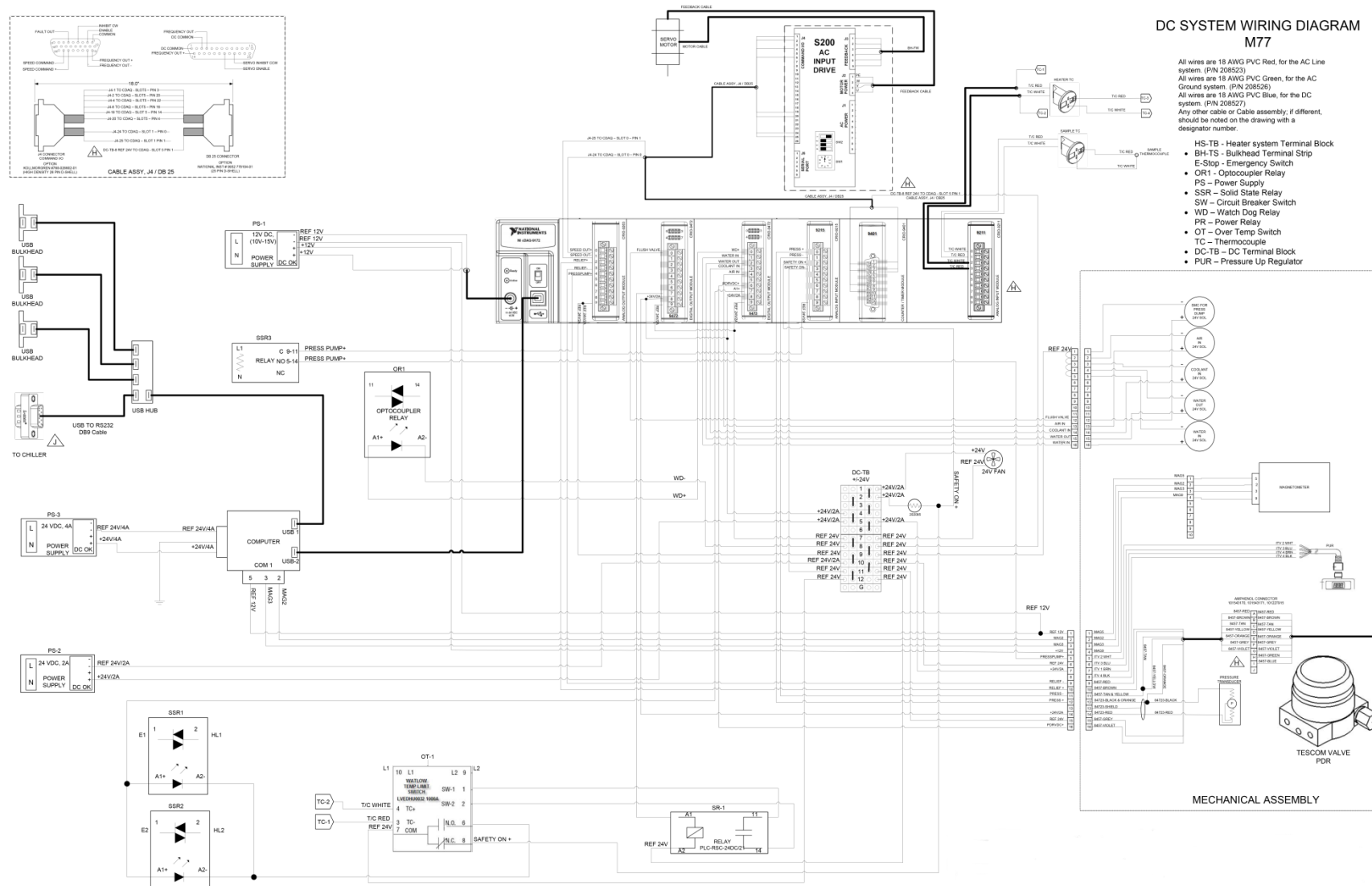


Figure 9-12 iX77 DC Wiring System, Rev J

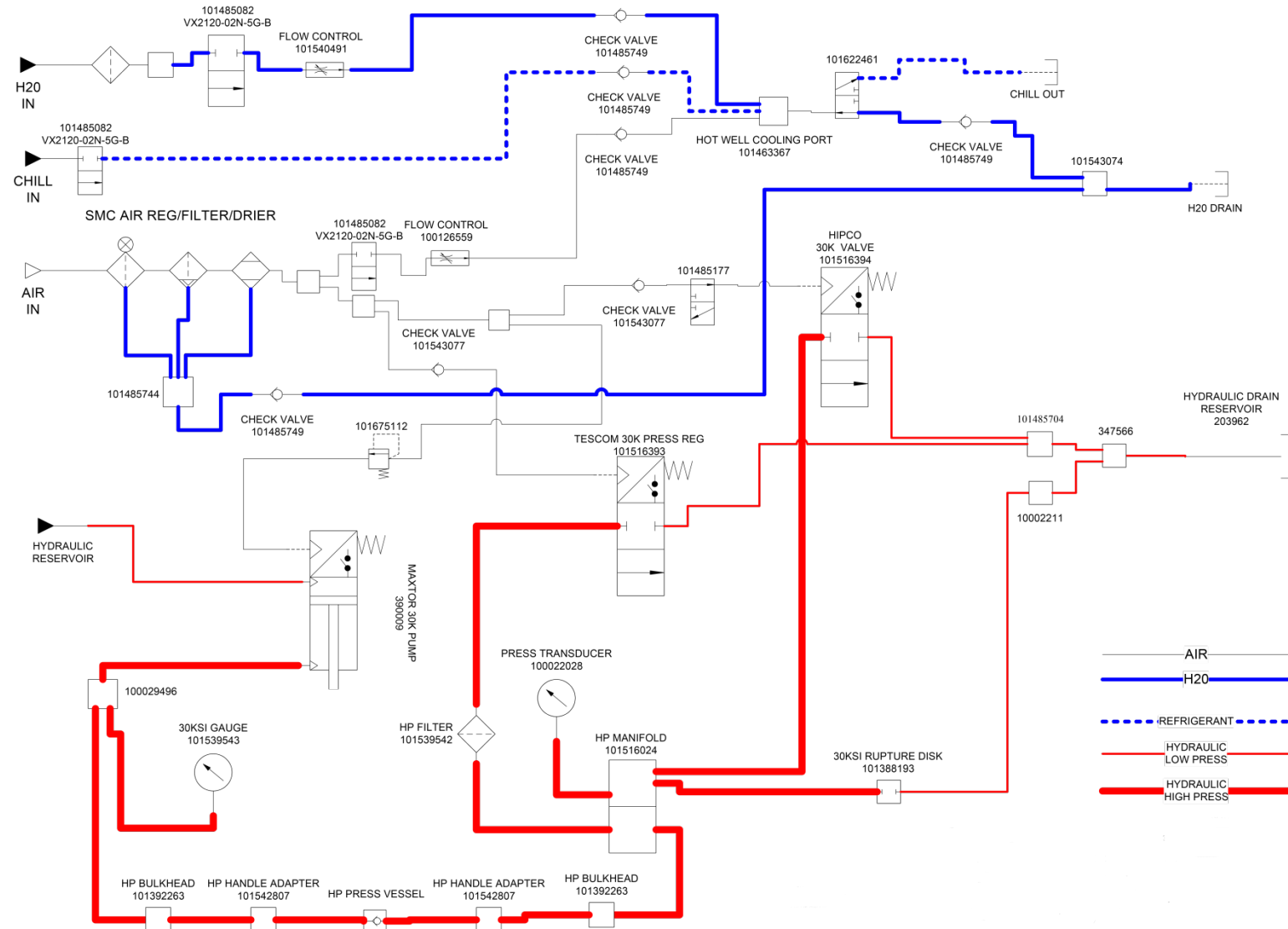


Figure 9-13 iX77 Mechanical Schematic, Rev B

### 9.3 Test Cell Assembly (101511610) Parts

Table 9-9 iX77 Cell Assembly, P/N 101511610, Rev E

Find No.	Part No.	Quantity	Description
0001	101531620	1	CELL SET VISCOMETER
0002	208955	1	BAFFLE
0003	101526728	1	ROTOR
0004	208897	1	BOB
0005	208968	1	PIVOT,THERMOWELL
0006	101526730	1	MAGNET, DRIVEN
0007	101526729	1	MAGNET HOLDER
0008	101626628	1	BUSHING, ROTOR
0009	208885	1	NUT, PIVOT STEM
0010	208898	1	BUSHING, PIVOT
0011	372075	2	SCREW - BIND HD - 8-32 X 1-3/8 - SS
0012	203367	1	BUSHING ANGULAR CONTACT
0013	203364	1	PIN, PIVOT
0014	208946	1	GUIDE, PIVOT CELL
0015	203365	2	VEE JEWEL
0016	203441	1	10-32 X 3/16 SHSS
0017	101526731	1	SHAFT, BOB
0018	101530674	3	PORT ADAPTOR
0019	101530675	1	PORT PLUG
0020	204920	1	RETAINER RING
0021	101530676	1	NUT, PLUG RETAINER
0022	204607	1	O-RING 0.209 ID X .070 NITRILE
0023	208904	1	NUT, UPPER PILOT, CELL ASSEMBLY
0024	208892	1	LIMIT STOP MODEL
0025	100124315	2	ROLL PIN, 1/16 X 3/8, SS
0026	208893	1	CAGE
0027	203433	1	6-32 X 1/4 LG SHCS
0028	100123611	2	SCREW, SET, #6-32 X 3/16, ALLEN
0029	203432	2	6-32 X 1 LG SOC HD CAP SS
0030	208902	1	TORSION SPRING
0031	207595	1	UPPER SLEEVE CLAMP
0032	208894	1	MOUNT, UPPER MAGNET
0033	208896	1	PIVOT CAP
0034	205057	1	MAGNET, UPPER CELL
0035	208900	1	SPRING HOLDER
0036	207775	2	6-32 X 5/32 HSS NI STAINLESS HEX SOCKET SET SCREW
0037	207594	1	SLEEVE, ZEROING
0038	208942	1	VENT TUBE
0039	203366	1	BALL 3/16 IN. DIA, SS
0040	101736752	1	O-RING, SIZE 2-220, COLOR WHITE, 600 DEG F, .139 IN WALL
0041	101623710	2	O-RING, SIZE 2-226, COLOR WHITE, 600 DEG F, ID 1.984 IN X 0.139 IN WALL
0042	208939	1	RING BACKUP TOP CELL
0043	208940	1	RING BACKUP BOTTOM
0044	203388	1	8-32 X 1/4 LG-SHSS

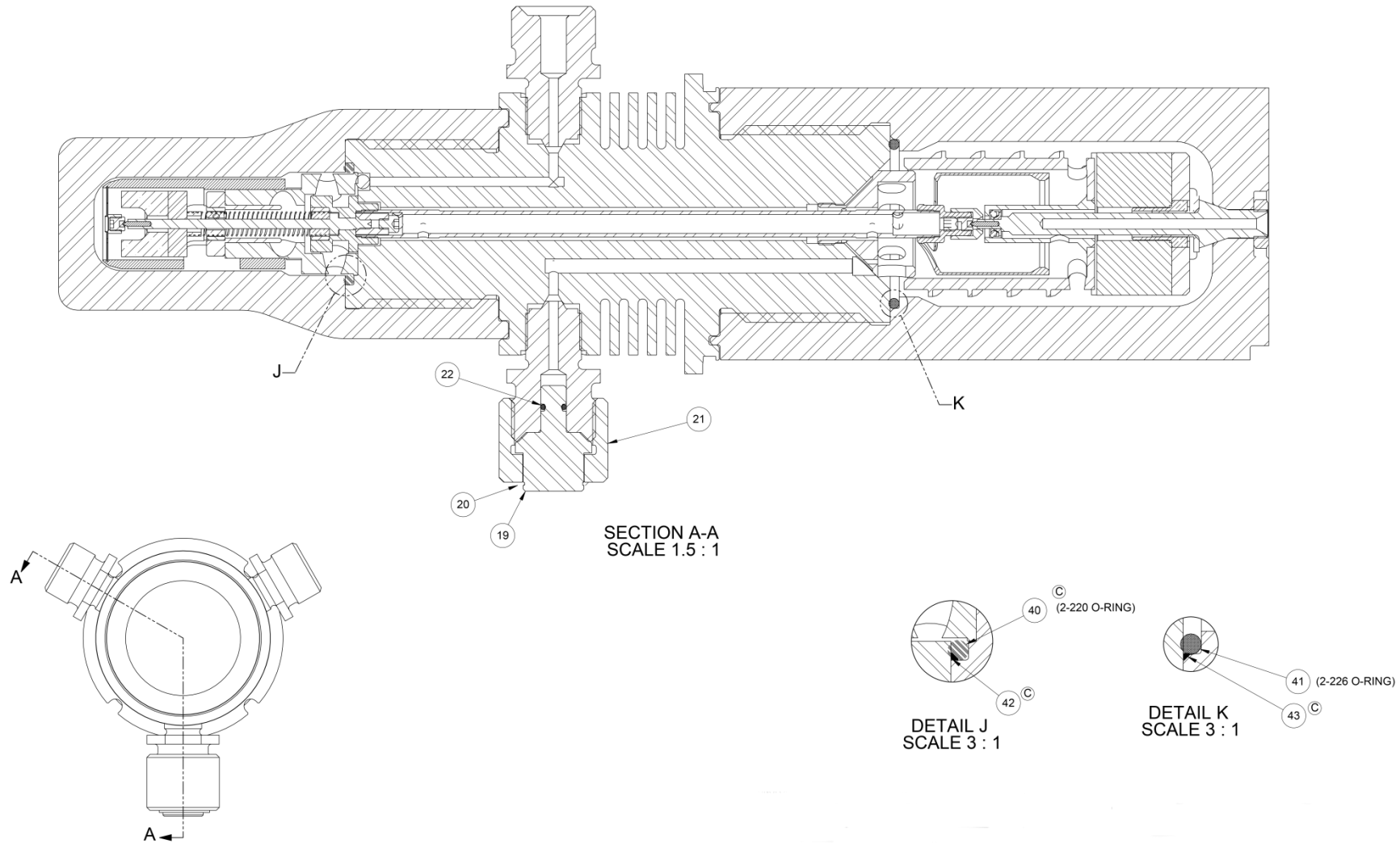


Figure 9-14 iX77 Cell Assembly, Rev E

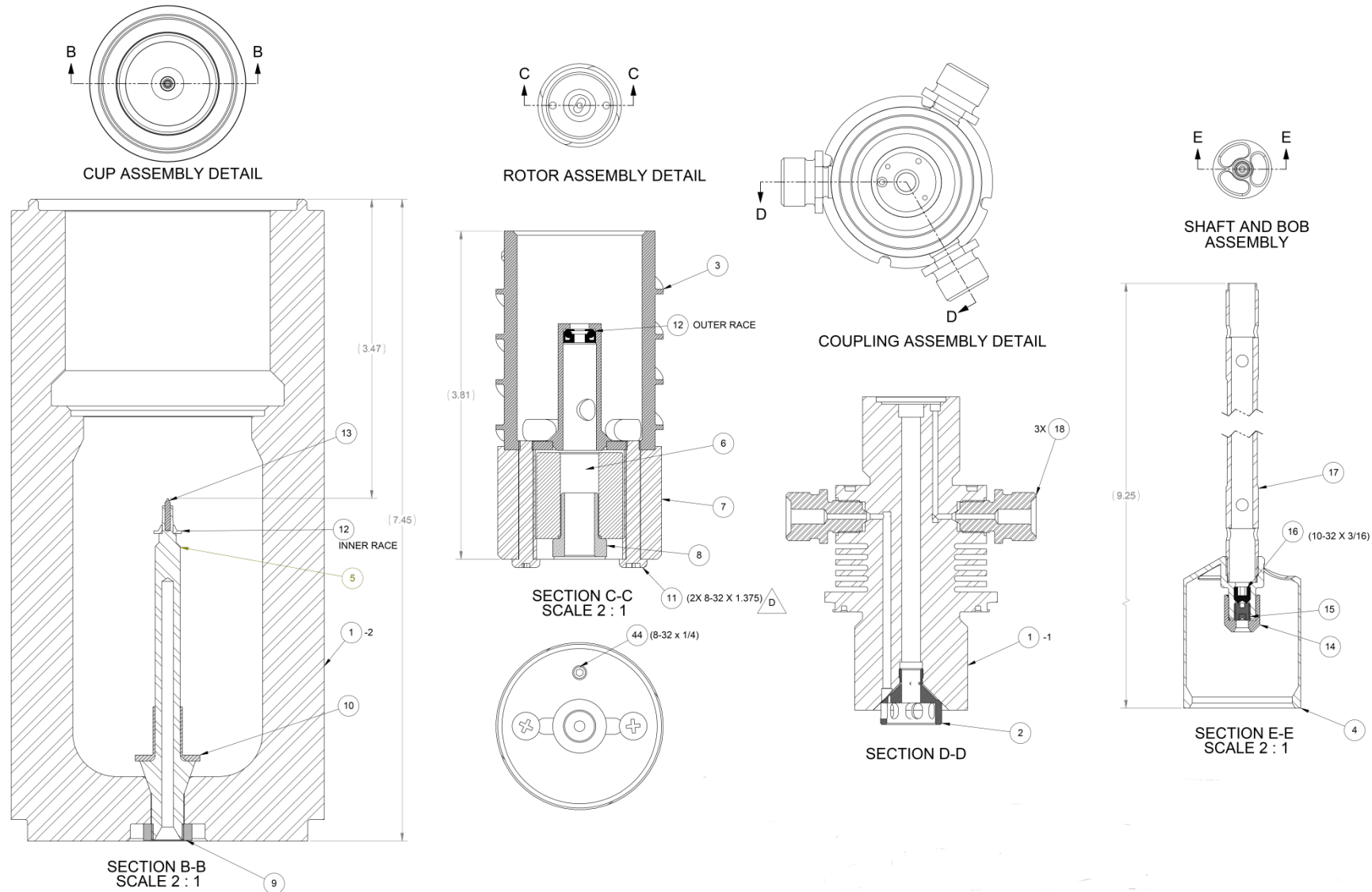


Figure 9-15 iX77 Cell Cup, Rotor, Coupling, Shaft & Bob, Rev E

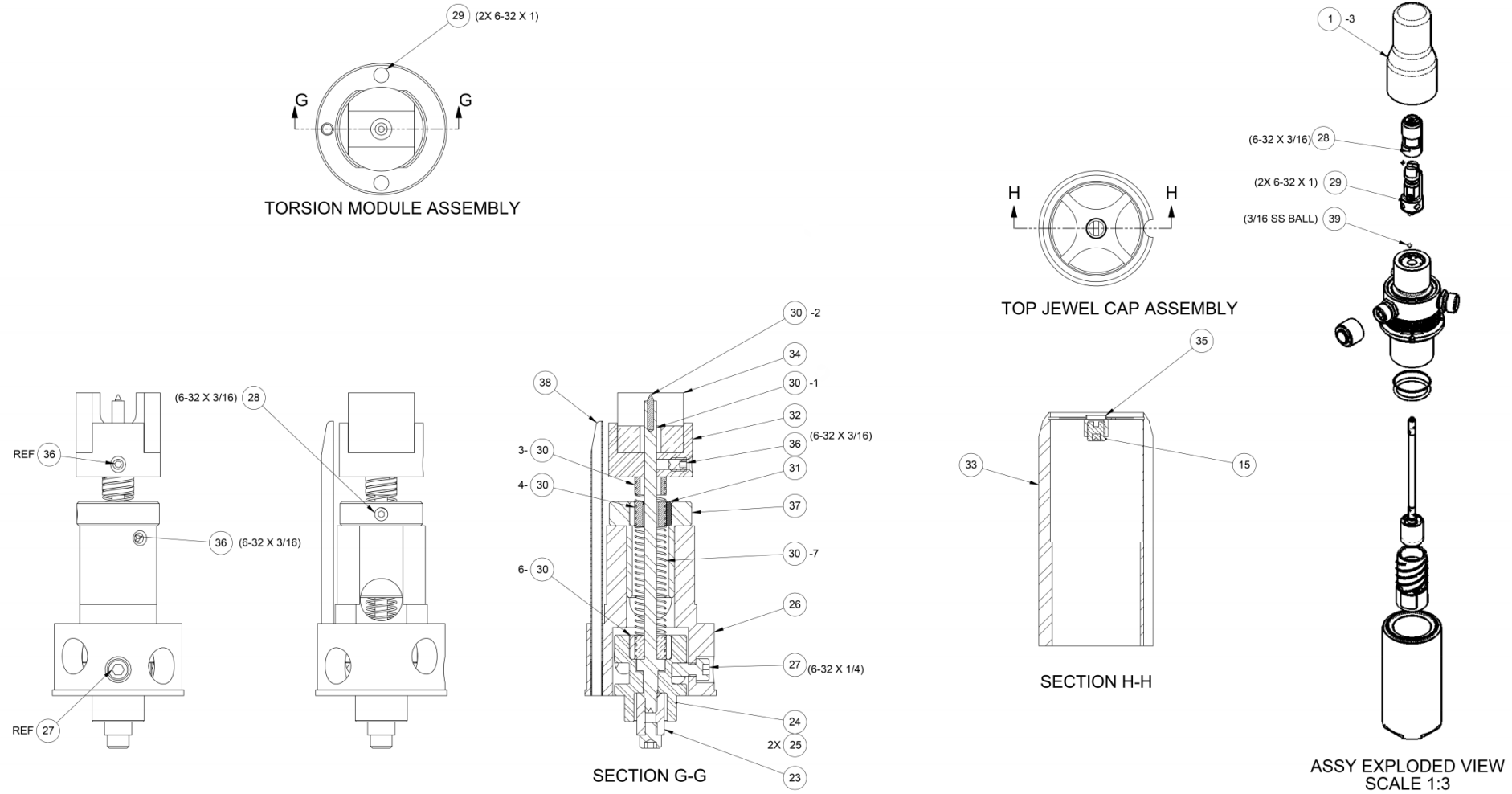


Figure 9-16 iX77 Torsion Module and Top Jewel Assemblies, Rev E



## 10 Warranty and Returns

### 10.1 Warranty

Fann Instrument Company warrants only title to the equipment, products and materials supplied and that the same are free from defects in workmanship and materials for one year from date of delivery. **THERE ARE NO WARRANTIES, EXPRESS OR IMPLIED OF MERCHANTABILITY, FITNESS OR OTHERWISE BEYOND THOSE STATED IN THE IMMEDIATELY PRECEDING SENTENCE.** Fann's sole liability and Customer's exclusive remedy in any cause of action (whether in contract, tort, breach of warranty or otherwise) arising out of the sale, lease or use of any equipment, products or materials is expressly limited to the replacement of such on their return to Fann or, at Fann's option, to the allowance to Customer of credit for the cost of such items. In no event shall Fann be liable for special, incidental, indirect, consequential or punitive damages. Notwithstanding any specification or description in its catalogs, literature or brochures of materials used in the manufacture of its products, Fann reserves the right to substitute other materials without notice. Fann does not warrant in any way equipment, products, and material not manufactured by Fann, and such will be sold only with the warranties, if any, that are given by the manufacturer thereof. Fann will only pass through to Customer the warranty granted to it by the manufacturer of such items.

### 10.2 Returns

For your protection, items being returned must be carefully packed to prevent damage in shipment and insured against possible damage or loss. Fann will not be responsible for damage resulting from careless or insufficient packing.

Before returning items for any reason, authorization must be obtained from Fann Instrument Company. When applying for authorization, please include information regarding the reason the items are to be returned.

Our correspondence address:

**Fann Instrument Company**  
P.O. Box 4350  
Houston, Texas USA 77210

Telephone: 281-871-4482

Toll Free: 800-347-0450

FAX: 281-871-4446

Email [fanmail@fann.com](mailto:fanmail@fann.com)

Our shipping address:

**Fann Instrument Company**  
14851 Milner Road, Gate 5  
Houston, Texas USA 77032