

# Lost Circulation Material Evaluation Receiver Instruction Manual



Manual No. D00943152, Revision B

Instrument No. 102308743

## LCM Evaluation Receiver Instruction Manual

©2016 Fann Instrument Company

Houston, Texas, USA

All rights reserved. No part of this work covered by the copyright hereon may be reproduced or copied in any form or by any means (graphic, electronic, or mechanical) without first receiving the written permission of Fann Instrument Company, Houston, Texas, USA.

Printed in USA.

The information contained in this document includes concepts, methods, and apparatus which may be covered by U.S. Patents. Fann Instrument Company reserves the right to make improvements in design, construction, and appearance of our products without prior notice.

FANN<sup>®</sup> and the FANN logo are registered trademarks of Fann Instrument Company in the United States and/or other countries. All other trademarks mentioned in the operating instructions are the exclusive property of the respective manufacturers.

### Contact Fann Instrument Company

<b>Phone</b>	1-281-871-4482 1- 800-347-0450
<b>Fax</b>	1-281-871-4358
<b>Postal Address</b>	Fann Instrument Company P.O. Box 4350 Houston, Texas, 77210 USA
<b>Shipping Address</b>	Fann Instrument Company 14851 Milner Road, Gate 5 Houston, Texas, 77032, USA
<b>Online</b>	<a href="http://www.fann.com">www.fann.com</a> <a href="mailto:fannmail@fann.com">fannmail@fann.com</a>

## Table of Contents

1	Introduction .....	4
	1.1 Document Conventions .....	5
2	Safety .....	6
	2.1 Safe Pressurization .....	6
	2.2 Safe Heating .....	7
	2.3 Safe Electrical Operation.....	7
3	Features and Specifications .....	9
4	Test Method with LCM Evaluation Receiver .....	10
	4.1 Testing with Stainless Steel Slotted Discs .....	13
5	The Vug Adapter Kit.....	15
	5.1 Overview .....	15
	5.2 Parts List.....	15
	5.3 Assembly Instructions .....	16
6	Maintenance.....	23
	6.1 Cleaning.....	23
	6.2 O-rings .....	23
7	Parts List.....	24
8	Warranty and Returns .....	26
	8.1 Warranty .....	26
	8.2 Returns .....	26

## List of Figures

Figure 3-1	LCM Evaluation Receiver .....	9
Figure 4-1	LCM Receiver Connected to PPA Cell.....	12
Figure 7-1	LCM Evaluation Receiver Diagram .....	24

## List of Tables

Table 3-1	LCM Evaluation Receiver, P/N 102308743 Specifications .....	9
Table 4-1	Stainless Steel Slotted Discs (0.25 in. Thick) .....	13
Table 4-2	Tapered Slotted Disc .....	14
Table 5-1	Parts List for Vug Testing.....	15
Table 7-1	LCM Evaluation Receiver, P/N 102308743 Parts List .....	24
Table 7-2	Parts List for Vug Testing.....	25

## **1 Introduction**

The Lost Circulation Material (LCM) Evaluation Receiver is an alternative back pressure receiver for Fann Permeability Plugging Apparatus (PPA) and Automated Permeability Plugging Apparatus (APPA).

The LCM Evaluation Receiver can handle larger particles without plugging. This new design is beneficial for testing drilling fluids containing various sized material at engineered concentrations. These special drilling fluids seal multiple lost circulation situations, including severe fluid losses.

1.1 Document Conventions

The following icons are used as necessary in this instruction manual.



**NOTE.** Notes emphasize additional information that may be useful to the reader.



**CAUTION.** Describes a situation or practice that requires operator awareness or action in order to avoid undesirable consequences.



**MANDATORY ACTION.** Gives directions that, if not observed, could result in loss of data or in damage to equipment.



**WARNING!** Describes an unsafe condition or practice that if not corrected, could result in personal injury or threat to health.



**ELECTRICITY WARNING!** Alerts the operator that there is risk of electric shock.



**HOT SURFACE!** Alerts the operator that there is a hot surface and that there is risk of getting burned if the surface is touched.



**EXPLOSION RISK!** Alerts the operator that there is risk of explosion.

## 2 Safety

Safe laboratory practices and procedures should be observed while operating and maintaining the LCM Evaluation Receiver. Please review safety practices listed in Fann PPA and APPA instruction manuals (summarized below) and API Recommended Practice for Field Testing Water Based Drilling Fluids, API RP 13B-1, Annex J.

### 2.1 Safe Pressurization

Follow these instructions for a hydraulic pressurization system and backpressure receiver.

#### 2.1.1 Hydraulic Pressurization System

Make sure that the hydraulic pressure has been released and that the pressure gauge reads zero before performing these actions:

- Disconnecting the hose from the cell at quick connector
- Removing the cell from the heating chamber
- Moving the APPA
- Refilling the oil reservoir with hydraulic fluid
- Performing any maintenance

When refilling or repairing the hydraulic system, wipe spilled oil. Oil on the floor is a fall hazard. Spilled oil attracts dirt and can be a fire hazard.

When assembling the cell, make sure that the O-rings in the end caps are properly seated and the retainer ring is properly tightened.

#### 2.1.2 Back Pressure Receiver

For temperatures greater than the boiling point of the sample fluid, the backpressure receiver must be pressurized to prevent vaporization of the filtrate.

#### Gases

- Use either nitrogen or carbon dioxide to pressurize the backpressure receiver.
- For the APPA, nitrogen pressurizes the backpressure receiver.
- Nitrogen must be supplied in an approved nitrogen gas cylinder or laboratory supply system. Nitrogen cylinders must be secured to meet safety standards.
- Carbon dioxide is usually supplied in small cartridges, which contain approximately 900 psi (6206 kPa) pressure. Carbon dioxide can also be supplied in cylinders.



Do NOT allow carbon dioxide cartridges to be heated or exposed to fire. They can explode if overheated.

---

## Pressure Regulators

- Maintain pressure regulators in good condition.
- Never use oil on pressure regulators.
- Leaking pressurization systems, hydraulic or pneumatic, should be repaired or replaced.
- Regularly inspect gauges, fittings, and hoses. Check for leaks.
- Periodically test the safety relief valve on the pressurization manifold to verify it will relieve if excessive pressure should occur. Never plug or bypass this safety valve.
- When pressurizing the backpressure assembly, always open the supply pressure first, and then adjust the regulator.
- Do not attempt to pressurize higher than the equipment is rated for or above the relief valve settings.
- When de-pressurizing, shut off the supply pressure, bleed the system of pressure, and then back out the regulator T-screw.

## 2.2 Safe Heating

Caution should be exercised by all personnel working with the APPA or working in the area where the APPA is in operation to avoid accidental injury caused by touching the heating chamber or cell assembly when they are hot. The heating chamber can operate at a temperature that will cause burns if touched. Safeguard the equipment after the test ends long enough for it to cool. It can still cause burns even after it has been turned off.

Removing the cell before it has cooled and placing it in water is very dangerous. This practice is not recommended because the user could be severely burned by the steam. Also the user could be burned if the cell is touched or accidentally dropped.

Be careful when handling a hot cell. Wear thermally insulated gloves. The recommended procedure is to let the cell cool in the heating chamber before removing it.

A cell removal tool (P/N 209497) is available for handling the cell assembly and removing it from the heating chamber. Its use will reduce the chances of accidentally dropping a cell or being burned by a hot cell.

## 2.3 Safe Electrical Operation

Make sure the electrical source is fused and grounded.

Verify that the power cord is in good condition and has the proper ground connection.

Electrical problems in the wiring or heaters may not be obvious by looking at the equipment. If a fuse blows, circuit breakers trip, the heating time seems too long or the thermostat control does not respond, electrical repair may be required.

Always test the heating chamber for proper operation after repair or part replacement.



---

Always disconnect the power cable before attempting any repair.

---



### 3 Features and Specifications

The LCM Evaluation Receiver can handle drilling fluids containing various particle sizes without plugging. The lower nipple has an internal diameter of 7 mm (0.28 in.), which is the smallest orifice in this receiver. The original back pressure receiver (100 ml) has 2.4 mm (0.10 in.) orifices and may plug, preventing fluid loss (a failed test).

This receiver comes with a re-engineered PPA cell cap that fits securely into all Fann PPA cells (Figure 3-1).

**Table 3-1 LCM Evaluation Receiver, P/N 102308743 Specifications**

<b>Volume</b>	178 ml
<b>Orifice Size</b>	7 mm (0.28 in.)
<b>Dimensions</b> <i>(Length x Diameter)</i>	16 x 3 inches 41 x 7.6 centimeters
<b>Weight</b>	8.5 lb (3.85 kg)

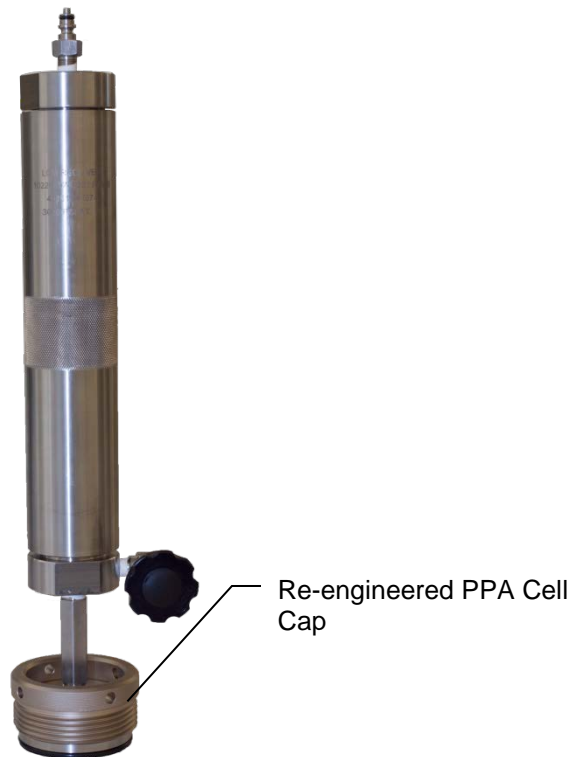

**Figure 3-1 LCM Evaluation Receiver**

## 4 Test Method with LCM Evaluation Receiver



---

This test follows API Recommended Practice for Field Testing Water Based Drilling Fluids, API RP 13B-1, Annex J.

---



---

Refer to Fann instruction manuals: PPA Manual Number 204249 and APPA Manual Number 102196683, available at [www.fann.com](http://www.fann.com)

---

1. This receiver replaces the original receiver and the original cap of the PPA equipment (Figure 4-1). Assemble the PPA cell as described in the Fann PPA instruction manual.
2. Fill the cell with 170 ml of the LCM treated sample.



---

The LCM Evaluation Receiver holds 190 ml. To prevent overfilling and fluid flowing into the nitrogen regulator, do not fill the PPA cell with more than 170 ml of sample.

---

3. Attach the hydraulic hose. Raise the fluid level (manually for PPA and automatic prime for the APPA) to sit below the O-ring groove
4. Select the appropriate slotted disc for the test (Table 4-1). Place the disc on top of the O-ring in the cell.



---

The slotted disc has a raised edge on one side. This edge should be facing up as shown in the Figure 4-1 right side callout.

---

5. Insert the PPA cell cap into the top of the PPA cell (Figure 4-1) and tighten the cell cap ring with the spanner wrench (P/N 206864).

6. Disconnect the hydraulic hose and place the completed cell assembly in the preheated heater jacket.
7. Reconnect the hydraulic hose.
8. The nipple between the receiver and the PPA cell should be filled with enough water to obtain accurate fluid loss measurement.
  - a. Remove the LCM Receiver top cap and pour approximately 20 ml of water into the receiver body.
  - b. Replace the top cap.
  - c. Open the collection valve and drain excess water from the receiver. The receiver should now contain approximately 10 ml or less of water.
9. Connect the nitrogen supply hose.
10. Apply the appropriate pressure as described in the PPA and APPA instruction manuals.
11. When the test temperature is reached, increase the pressure from the bottom side to the required pressure differential.
12. Collect samples from the collection valve at the desired time intervals.



---

**For the PPA:** If pressure does not build or hold after ~ 20 strokes with the hydraulic hand pump, then this indicates a 'total fluid loss' and the test needs to be stopped. (According to the hydraulic pump manual, each stroke would be equivalent to 5 cm<sup>3</sup> of fluid and 325 psi maximum pressure.)

---



---

**For the APPA:** If pressure does not build or hold to the required differential pressure with the LCM Evaluation Receiver connected to the APPA, press the APPA red knob to stop the test.

---

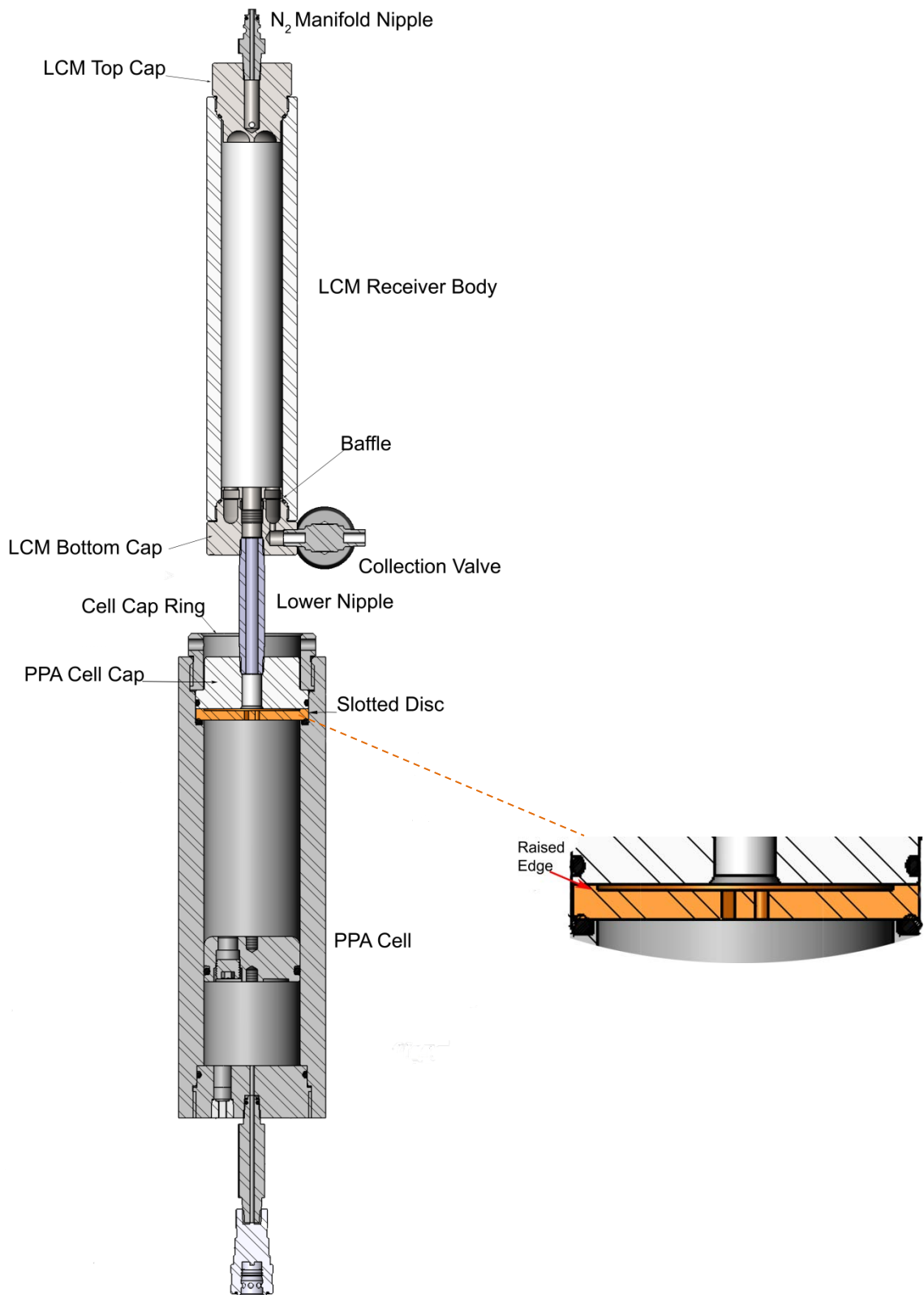





Figure 4-1 LCM Receiver Connected to PPA Cell

**4.1 Testing with Stainless Steel Slotted Discs**

To test LCM fluids containing larger particle sizes, the following discs are recommended (these discs are available for purchase separately.)

**Table 4-1 Stainless Steel Slotted Discs (0.25 in. Thick)**

Slot Description			Image	Part No.
Length Inch	Width Inch/Micron	Type		
1.000	0.008 in. 203.2 μ	Constant Area 10 radial arms		<b>101896606</b>
1.000	0.02 in. 508 μ	Constant Area 4 radial arms		<b>101896607</b>
0.531	0.04 in. 1016 μ	Constant Area 4 radial arms		<b>101896608</b>
0.381	0.06 in. 1524 μ	Constant Area 4 radial arms		<b>101896609</b>

Slot Description			Image	Part No.
Length Inch	Width Inch/Micron	Type		
0.313	0.08 in. 2032 μ	Constant Area 4 radial arms		101896610
0.279	0.1 in. 2540 μ	Constant Area 4 radial arms		101896611
0.428	0.12 in. 3048 μ	Constant Area 2 radial arms		101911230

**Table 4-2 Tapered Slotted Disc**

Slot Description				Image	Thickness	Part No.
Length Inch	Width Inch	Width Micron	Type			
1.700	0.04 to 0.1	1016 to 2540	Tapered Slot		1.64	101909848

## 5 The Vug Adapter Kit



### 5.1 Overview

The Vug Adapter is a component designed for the LCM Evaluation Receiver to allow for larger volumes of material to pass through the test media before plugging. A distinct difference with the tests performed with the Vug Adapter is that no port exists to measure fluid loss during the test. Also, the traditional orifice used between the PPA cell and the LCM Evaluation receiver is approximately ¼” (6.35 mm) diameter. The Vug Adapter has an inner diameter of 1.25” (31.75 mm) and also allows for a new type of insert not previously available. The Vug Adapter is compatible throughout all temperature and pressure ranges of the LCM Evaluation Receiver.

### 5.2 Vug Adapter Parts List

**Table 5-1 Parts List for Vug Testing**

<b>Part Number</b>	<b>Part Description</b>
102639011	ADAPTER KIT FOR LCM RECEIVER*
102636811	ADJUSTABLE SLOTTED DISC WITH GAUGE FOR LCM TESTING
102551596	VUG ADAPTER INSERT, 10 MM SLOT
102551597	VUG ADAPTER INSTER, 12 MM SLOT

\*The adapter kit (102639011) includes the adapter (102551605), 10 sets of O-rings (204629, 102639899, 101730954), and an adapter ring (209654) to facilitate the use of the Vug Adapter inserts.

See section 7 for complete parts lists.

### 5.3 Assembly Instructions



1. Three O-rings exist in the adapter; one on above the threads, one at the bottom, and one on the inside. Coat all O-rings in high temperature grease.





2. Add an insert if desired to the bottom of the adapter



The insert should be flush with the bottom when installed correct



3. Place the threaded retaining ring on top of the adapter



4. When using an insert, an adapter ring (209654) must be used



## 5. PPA Cell Assembly with Vug insert and adapter ring

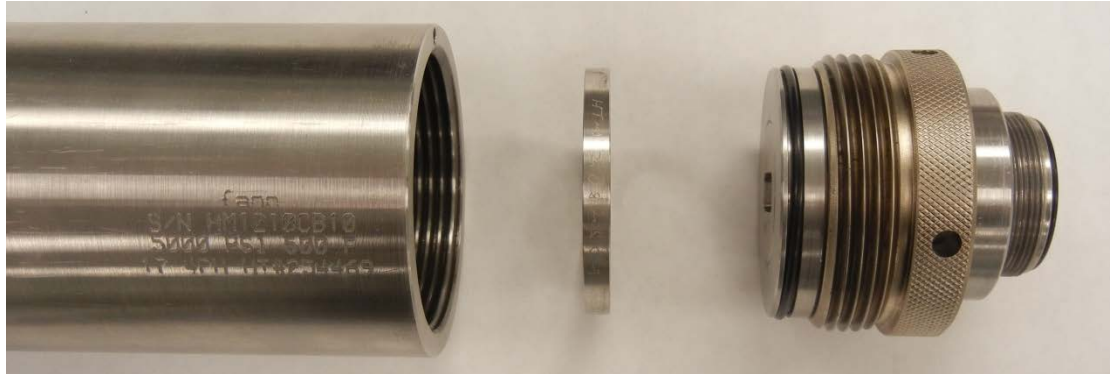

The adapter ring isn't necessary if you are using the adjustable slotted disc.



Insert the adjustable slotted disc, as shown below



The fully assembled adapter fastened to the PPA cell with the adjustable slotted disc.



- The bottom portion of the LCM Evaluation Receiver must be removed before it can be connected to the Vug Adapter.





7. Insert the receiver into the PPA cell and fasten the retaining ring



## **6 Maintenance**

### **6.1 Cleaning**

Standard laboratory procedures apply when cleaning the LCM Evaluation Receiver. After each test, disassemble and thoroughly clean and dry the receiver, including the O-rings and O-ring grooves.

### **6.2 O-rings**

Inspect all O-rings for cuts or nicks while cleaning them. Check for hardening or brittleness. If the O-rings have been exposed to temperatures above 425°F (218°C), replace them.

Replace all damaged O-rings.

Lubricate all O-rings before installing them. For most applications, high temperature grease (thin coating) is sufficient. However, since some O-rings contact the sample, the lubricant must be compatible with the sample and must be applied sparingly.

**7 Parts List**

**Table 7-1 LCM Evaluation Receiver, P/N 102308743 Parts List**

Item No.	Part No.	Quantity	Description
1	205649	1	O-RING, 0.316 X 0.176 X 0.070 IN.
2	209441	1	BACKPRESSURE NIPPLE, 1/8 NPT
3	102473675	1	TOP CAP
4	205668	2	O-RING 1-3/8 X 1/16 IN. NITRILE
5	102473674	1	LCM EVALUATION RECEIVER BODY
6	102473677	1	BAFFLE
7	102473676	1	BOTTOM CAP
8	102473680	1	NIPPLE, 3 X 1/4 IN.
9	208759	1	NEEDLE VALVE, 1/8 X 1/8 IN. CHROME
10	102473678	1	CELL CAP RING
11	102473679	1	CELL CAP
12	204627	1	O-RING, 2.443 X 2.237 X 0.103 IN.

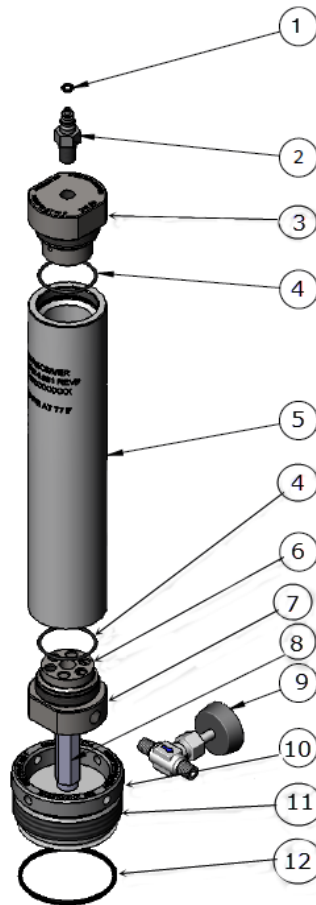

**Figure 7-1 LCM Evaluation Receiver Diagram**



**Table 7-2 Parts List for Vug Testing**

<b>Part Number</b>	<b>Description</b>
102639011	ADAPTER KIT FOR LCM RECEIVER*
102636811	ADJUSTABLE SLOTTED DISC WITH GAUGE FOR LCM TESTING
102551596	VUG ADAPTER INSERT, 10 MM SLOT
102551597	VUG ADAPTER INSTER, 12 MM SLOT

## 8 Warranty and Returns

### 8.1 Warranty

Fann Instrument Company warrants only title to the equipment, products and materials supplied and that the same are free from defects in workmanship and materials for one year from date of delivery. THERE ARE NO WARRANTIES, EXPRESS OR IMPLIED OF MERCHANTABILITY, FITNESS OR OTHERWISE BEYOND THOSE STATED IN THE IMMEDIATELY PRECEDING SENTENCE. Fann's sole liability and Customer's exclusive remedy in any cause of action (whether in contract, tort, breach of warranty or otherwise) arising out of the sale, lease or use of any equipment, products or materials is expressly limited to the replacement of such on their return to Fann or, at Fann's option, to the allowance to Customer of credit for the cost of such items. In no event shall Fann be liable for special, incidental, indirect, consequential or punitive damages. Notwithstanding any specification or description in its catalogs, literature or brochures of materials used in the manufacture of its products, Fann reserves the right to substitute other materials without notice. Fann does not warrant in any way equipment, products, and material not manufactured by Fann, and such will be sold only with the warranties, if any, that are given by the manufacturer thereof. Fann will only pass through to Customer the warranty granted to it by the manufacturer of such items.

### 8.2 Returns

For your protection, items being returned must be carefully packed to prevent damage in shipment and insured against possible damage or loss. Fann will not be responsible for damage resulting from careless or insufficient packing.

Before returning items for any reason, authorization must be obtained from Fann Instrument Company. When applying for authorization, please include information regarding the reason the items are to be returned.

Our correspondence address:

**Fann Instrument Company**  
P.O. Box 4350  
Houston, Texas USA 77210

Telephone: 281-871-4482

Toll Free: 800-347-0450

FAX: 281-871-4446

Email [fannmail@fann.com](mailto:fannmail@fann.com)

Our shipping address:

**Fann Instrument Company**  
14851 Milner Road, Gate 5  
Houston, Texas USA 77032