

HPHT SafeCell

Instruction Manual



Manual No. D00850888, Revision D

**Instrument Nos. 102312548
102416675
102474585
102416676
102529505**

HPHT SafeCell Instruction Manual

©2015 Fann Instrument Company

Houston, Texas, USA

All rights reserved. No part of this work covered by the copyright hereon may be reproduced or copied in any form or by any means (graphic, electronic, or mechanical) without first receiving the written permission of Fann Instrument Company, Houston, Texas, USA.

Printed in USA.

The information contained in this document includes concepts, methods, and apparatus which may be covered by U.S. Patents. Fann Instrument Company reserves the right to make improvements in design, construction, and appearance of our products without prior notice.

FANN[®] and the FANN logo are registered trademarks of Fann Instrument Company in the United States and/or other countries. All other trademarks mentioned in the operating instructions are the exclusive property of the respective manufacturers.

Contact Fann Instrument Company

Phone 1-281-871-4482
 1-800-347-0450

Fax 1-281-871-4358

Postal Address Fann Instrument Company
 P.O. Box 4350
 Houston, Texas, 77210 USA

Shipping Address Fann Instrument Company
 14851 Milner Road, Gate 5
 Houston, Texas, 77032, USA

Online www.fann.com
 fannmail@fann.com

Table of Contents

1	Introduction	5
1.1	Document Conventions	6
2	Safety	7
2.1	Safe Pressurization	7
2.2	Safe Heating	8
2.3	Safe Test Cell Maintenance	9
3	Features and Specifications	10
4	Operation	12
4.1	SafeCell Assembly	12
4.2	SafeCell Disassembly	14
4.3	Double Ended Cell Operation	14
5	Cleaning and Maintenance	16
5.1	Cell Maintenance	16
5.2	Valve Stems	16
5.3	Cell Corrosion	17
5.4	CellTell™ Maintenance	18
6	Parts List	20
7	Warranty and Returns	25
7.1	Warranty	25
7.2	Returns	25

List of Figures

Figure 3-1 HPHT SafeCell	11
Figure 4-1 SafeCell, fully assembled.....	12
Figure 4-2 Cell showing fill marks inside	12
Figure 4-3 Screen in cell	13
Figure 4-4 Cap Retainer installed	13
Figure 4-5 Cell Cap installed.....	13
Figure 5-1 Comparison of used valve stems	17
Figure 5-2 Resurfacing Tool (P/N 209500).....	17
Figure 6-1 SafeCell Assembly, 102312548	20
Figure 6-2 SafeCell Assembly, 102416675	21
Figure 6-3 SafeCell Assembly, 102474585	22
Figure 6-4 SafeCell Assembly, 102416676	23
Figure 6-5 SafeCell Assembly, 102529505	24

List of Tables

Table 3-1 HPHT SafeCell, Specifications.....	11
Table 6-1 SafeCell, Single-ended with CellTell™ Screen 102312548	20
Table 6-2 SafeCell, Single-ended with CellTell™ Filter Disc 102416675.....	21
Table 6-3 SafeCell, Double-ended with CellTell™ Screen 102474585	22
Table 6-4 SafeCell, Double-ended w/o CellTell™ 102416676.....	23
Table 6-5 SafeCell, Double-ended Two Caps f/ Screen w/o CellTell™ 102529505.....	24

1 Introduction

HPHT SafeCell is a high-temperature, high-pressure cell that is compatible with Fann HPHT Filter Press and HT4700 Heating Jacket. Its screw-in cap reduces the chance of opening the cell while under pressure. This new cap design also makes assembly and disassembly easier and faster; set screws are not used and a cell clamp is not required. CellTell™ Positive Pressure Indicator is built into the cell, providing additional protection.

SafeCell includes the cell body, cell cap, cap retainer, valve stems (2), filter screen, and O-rings. See parts lists for various configurations in Section 6.

1.1 Document Conventions

The following icons are used as necessary in this instruction manual.



NOTE. Notes emphasize additional information that may be useful to the reader.



CAUTION. Describes a situation or practice that requires operator awareness or action in order to avoid undesirable consequences.



MANDATORY ACTION. Gives directions that, if not observed, could result in loss of data or in damage to equipment.



WARNING! Describes an unsafe condition or practice that if not corrected, could result in personal injury or threat to health.



ELECTRICITY WARNING! Alerts the operator that there is risk of electric shock.



HOT SURFACE! Alerts the operator that there is a hot surface and that there is risk of getting burned if the surface is touched.



EXPLOSION RISK! Alerts the operator that there is risk of explosion.

2 Safety

Safe laboratory practices and procedures should be observed while operating and maintaining the HPHT SafeCell and heating jackets filter presses.

2.1 Safe Pressurization

- Always use nitrogen or carbon dioxide as the pressurization medium.
- Never connect this filter press cell to compressed oxygen or other non-recommended or flammable gas.
- If nitrogen is used, it must be supplied in an approved nitrogen gas cylinder, or the nitrogen supply system must be built into the laboratory. Nitrogen cylinders must be secured to meet all safety standards.
- Carbon dioxide is normally supplied in small cartridges which contain approximately 900 psig (6205 kPa) pressure. They are primarily used for field operations.



Do NOT allow the carbon dioxide cartridges to be heated or exposed to fire. They can explode if overheated.

- Maintain pressure regulators in good condition.
- Never use oil on pressure regulators.
- Leaking pressurization systems should be repaired or replaced.
- Gauges, fittings and hoses should be kept in good condition and leaks should be found and corrected.
- Periodically test the safety relief valves on the pressurization manifolds to verify that they will relieve excessive pressure. Never plug or bypass them.
- When pressurizing the aging cell always open the supply pressure first, and then adjust the regulator. Do not attempt to pressurize higher than the equipment pressure rating or the relief valve settings.
- When de-pressurizing, shut off the supply pressure, and bleed the system of pressure. Then turn the regulator T-screw counterclockwise.

2.1.1 HPHT SafeCell Cap

SafeCell is designed to reduce the chance of accidentally opening the cell while still under pressure. The screw-in cell cap is essentially impossible to remove without releasing internal pressure.

SafeCell also uses the CellTell™ Positive Pressure Indicator.

2.1.2 CellTell™ Positive Pressure Indicator

SafeCell includes the CellTell™ Positive Pressure Indicator to show when the cell is pressurized. This safety device provides additional protection if the normal pressure bleeding procedure does not operate due to plugging or other reasons. If this indicator can be depressed and will stay depressed, the cell does not have pressure in it, and it is safe to open. If the indicator cannot be depressed or will not stay depressed, the cell has pressure in it and **MUST NOT** be disassembled.

2.2 Safe Heating



Hot cells can cause severe burns. Wear proper hand protection when handling hot cells. The cell temperature should be less than 130°F (54°C) for safe handling.



The sample temperature in the cell must be reduced to less than 200°F (93°C) before pressure is released.

- Avoid touching the cell assembly or heating jacket while they are hot. Both instruments are still dangerously hot even after the test has ended and the heat has been turned off.
- It is recommended that cells be removed after they have cooled to a temperature in which they can be safely handled.
- When handling hot cells, use approved pads or gloves.
- Removing a hot cell immediately after a test and cooling it under running water is very dangerous. This practice is not recommended because there is risk of getting burned.
- Be careful when placing a hot cell in water. The hot steam that is produced can cause burns.

2.3 Safe Test Cell Maintenance



EXPLOSION RISK! Do NOT heat the heating jacket above the temperature rating of the test cell.

The filtration cell assembly is a pressure vessel.

These safety precautions should be followed to assure safe operation:

- Cell material should be compatible with the test sample.
- Cell bodies that show signs of stress cracking, or severe pitting must not be used.

3 Features and Specifications

The HPHT SafeCell (Figure 3-1) is a Type 17-4 stainless steel cell designed with a screw-in cell cap. This cap cannot be removed if the cell has pressure. This safety feature helps protect users from accidentally opening the cell without first releasing pressure.

The cell body also has safety features. Vent holes on the cell help reduce trapped pressure. CellTell™ indicator shows whether or not all pressure is released. The screw-in cap makes closing and opening the cell easier; this cap does not use set screws.

Refer to Table 3-1 for specifications.

SafeCell can be used with existing Fann HPHT Filter Presses:

- Model 175CT, 115V Heating Jacket, P/N 209492
- Model 175CT, 230V Heating Jacket, P/N 209506
- HT4700 Heating Jacket, P/N 101631160

SafeCell is included in these HPHT Filter Press assemblies:

- HPHT Filter Press, Model 175CT, Single Ended Cell, 115 Volt, P/N 102386078
- HPHT Filter Press, Model 175CT, Single Ended Cell, 230 Volt, P/N 102386079
- HPHT Filter Press, Model HT4700, Double Ended Cell, CO₂ Pressurized, P/N 102196306
- HPHT Filter Press, Model HT4700, Single Ended Cell, CO₂ Pressurized, P/N 102195986
- HPHT Filter Press, Model HT4700, Double Ended Cell, N₂O Pressurized, P/N 102197003
- HPHT Filter Press, Model HT4700, Single Ended Cell, N₂O Pressurized, P/N 102197111

Table 3-1 HPHT SafeCell, Specifications

Category	Specification	
Test Temperature / Maximum Volume	350°F (177°C)	130 ml
	500°F (260°C)	100 ml
Maximum Working Pressure	1800 psig (12,410 kPa)	
Weight	9 lb (4.1 kg)	

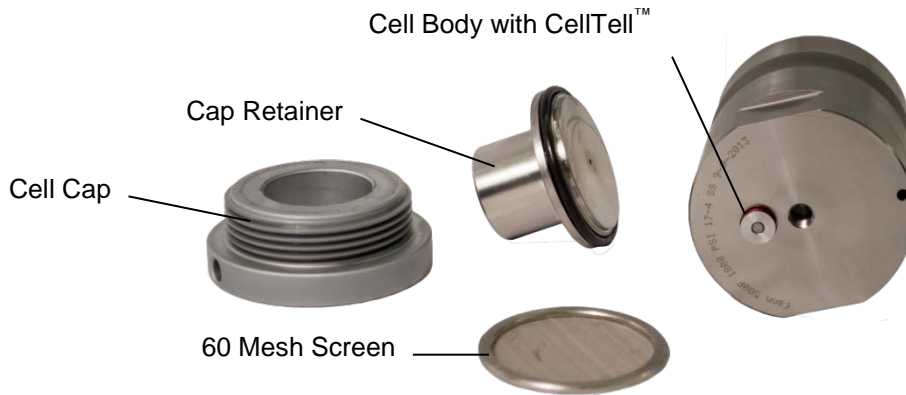

Figure 3-1 HPHT SafeCell

4 Operation

This section describes the assembly and disassembly of the SafeCell.



Figure 4-1 SafeCell, fully assembled

4.1 SafeCell Assembly

1. Check O-rings on the valve stems, cell, and cell cap. Lubricate the O-rings. It is recommended that O-rings are replaced after each test at temperatures above 350°F (177°C).
2. Place O-ring into groove in the cell body (Figure 4-2)
3. Add sample, approximately 130 ml to the top fill line for tests at 350°F (177°C) or 100 ml for tests at 500°F (260°C) (Figure 4-2).



Figure 4-2 Cell showing fill marks inside

4. Place filter paper on the O-ring in the cell body.
5. Put the screen on the filter paper (Figure 4-3)
6. Add the O-ring.

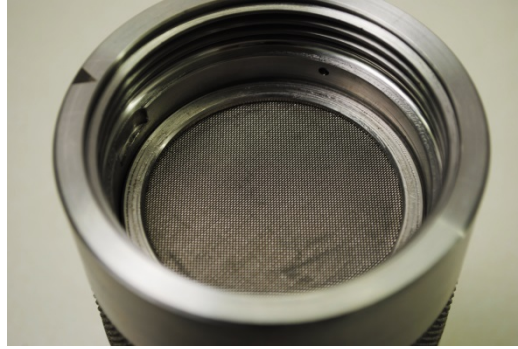

Figure 4-3 Screen in cell

7. Install the cap retainer, making sure its alignment pin is aligned with the arrow on the cell body (Figure 4-4).
8. Install the cell cap and turn until hand-tight (Figure 4-5).



The cell will not pressurize if it is not properly sealed.



Figure 4-4 Cap Retainer installed



Figure 4-5 Cell Cap installed

9. Install and tighten the valve stems.

10. Invert the assembled cell (Figure 4-1) and put it into the heating jacket (filter end down).
11. Follow API Recommended Practice for pressurizing the cell and performing a filtration test.

4.2 SafeCell Disassembly



Hot cells can cause severe burns. Wear proper hand protection when handling hot cells.



Cells can be removed from the heating jacket after cooling to a temperature at which they can be safely handled.

1. Slowly open the valve stems and allow pressure to release.
2. Make sure all pressure has been released. Press the CellTell™ safety indicator. It should depress and stay depressed if all pressure has been released.



If pressure is present, you will not be able to loosen the cell cap.

3. Twist the cell cap (right turn) to remove it. Also remove the retainer cap, O-rings, and screen.

4.3 Double Ended Cell Operation

Follow the steps in section 4 (see Figure 6-4 under Table 6-4)

1. Use the Spanner Wrench to install or remove the Bottom Cap.
2. The Double Ended Cell can be loaded from either end.
3. Place the cell in the Heating Jacket with the screen end down.
4. Always depressurize the cell from the end opposite the screen.

5. When disassembling the cell, follow SafeCell disassembly instructions in Section 4.2.
6. Remove the Cap Retainer and Cell Cap first.

5 Cleaning and Maintenance

After each test, thoroughly clean the cell, including the O-rings and grooves and dry it. Wash and dry the screen.

5.1 Cell Maintenance

1. Clean all parts, including the cell, cell cap, CellTell™ safety indicator, and valve stems with water. You may need to force water through the parts to dislodge any material, such as lost circulation material (LCM) or sample residue.
2. Use compressed air to dry the valve stems and CellTell™ indicator.
3. Inspect all parts for damage.
 - a. Examine the screen under a light. Shadowed areas indicate plugging; the screen needs cleaning.
 - b. Screens with scratches or holes must be replaced.
 - c. O-rings that are brittle, torn, or cracked must be replaced. Do not store O-rings between tests with grease applied to them.



Stopcock grease should only be applied to the O-rings immediately before a test.

- d. If the cone point of the valve stem is damaged, it must be replaced.

5.2 Valve Stems

A metal-to-metal pressure tight seal is made between the valve stem and its seat. Leaks can occur if either the valve stem or seat is damaged.

Inspect the cone point of the valve stem by removing the valve stem from the cap or body. If the point is damaged, replace the valve stem. For examples of damaged and undamaged valve stem points, see Figure 5-1.

If the point appears to be in good condition, but a leak exists, the seat in the cell or cap may be rough, making it difficult to seal. Use a 5/16-inch drill bit to resurface the seat. A resurfacing tool, composed of a 5/16 drill and handle (Part No. 209500), may be used. See Figure 5-2.

Regularly inspect valve stems for possible plugging with dried sample. A small drill or wire can be used to insure that both the cross bore and the main passage openings are clear.

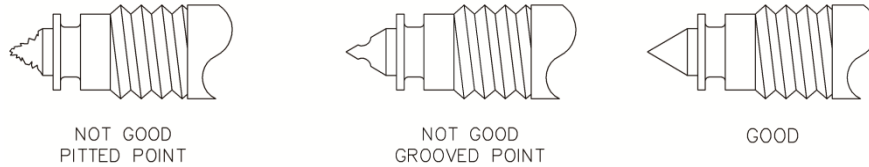

Figure 5-1 Comparison of used valve stems

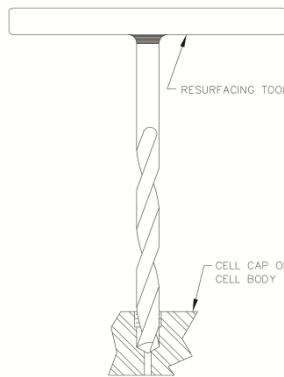

Figure 5-2 Resurfacing Tool (P/N 209500)

5.3 Cell Corrosion



Corrosion, pitting, and cracking can cause the cells to rupture.

Sample fluids under high-temperature and high-pressure conditions can may corrode the test cells and caps.

Periodically inspect the inside of the cell for corrosion. Use 320-grit (or finer) sandpaper, wet or dry, to remove light corrosion. Deep corrosion pitting may be removed by sand blasting the corroded area. Severe corrosion will require re-machining or re-surfacing the inside of the cell. If machining to 0.020-in. (0.5 mm) oversize does not remove all corrosion, replacing the cell is recommended. If corrosion cracks are evident, the cell should be replaced.

5.4 CellTell™ Maintenance

Thoroughly clean the CellTell™ Positive Pressure Indicator with water, making sure that any sample residue, lost circulation material (LCM), or other material is washed away.

Inspect the safety indicator for damage and worn or damaged O-rings.

Follow these steps to replace the O-rings:

1. Use a set of locking pliers to hold the red button of the indicator. Take care not to score the button.



2. While holding the red button with the pliers, use a flat-head screwdriver to unscrew the stem from the red bottom.



3. Using a small screwdriver or pick, remove the existing O-ring from the stem and discard.
4. Replace it with the new O-ring. Carefully using a small screwdriver or pick, place the O-ring into the slot.



5. Insert the stem back into the cap.



6. Use a small amount of Loctite[®] 242 on the threads.



7. Screw the red button back on until the stem is flush with the top of the red button.



8. Allow the Loctite[®] 242 to dry.

6 Parts List

In this section is listed and diagrammed the assembly parts for HPHT SafeCell configurations.

**Table 6-1 SafeCell, Single-ended with CellTell™ Screen
102312548**

Item No.	Part No.	Quantity	Description
1	102313352	1	CAP RETAINER, THREADED, MONEL K500
2	102313351	1	CELL CAP, 17-4 SS
3	102313350	1	CELL BODY, THREADED, 17- 4 SS, W / CELLTELL™
4a	102081076	1	SCREEN, 60 MESH
4b	209534	1	SCREEN, 325 MESH W / 60 MESH BACK-UP
5	209496	2	VALVE STEM, 416 SS, HARDENED RC30+
6	205649	9	O-RING, 0.176 ID x 0.0707 W , VITON
7	102365275	4	O-RING, 2-1/4 x1/8, VITON

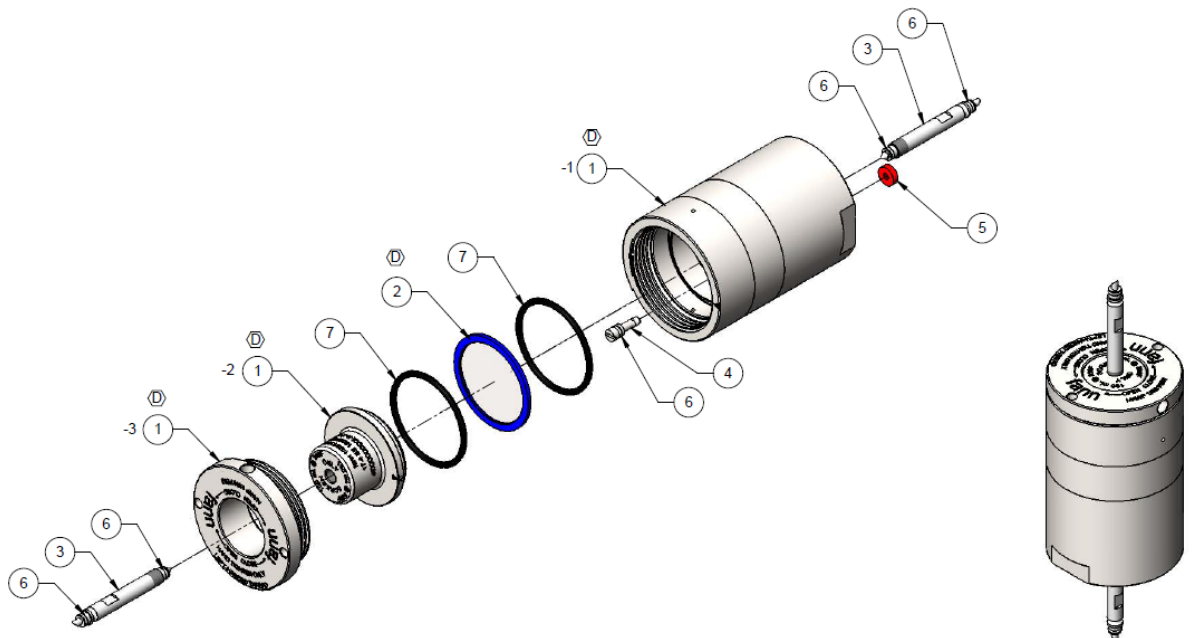

Figure 6-1 SafeCell Assembly, 102312548

**Table 6-2 SafeCell, Single-ended with CellTell™ Filter Disc
102416675**

Item No.	Part No.	Quantity	Description
1	102313352	1	CAP RETAINER, THREADED, MONEL K500
2	102416736	1	CELL CAP, 17-4 SS
3	102416734	1	CELL BODY, THREADED, 17-4 SS, W / CELLTELL™
4	210538	1	FILTER DISC, CERAMIC, API-20, 10/BOX
5	209496	2	VALVE STEM, 416 SS, HARDENED RC30+
6	205649	9	O-RING, 0.176 ID x 0.0707 W , VITON
7	102365275	4	O-RING, 2-1/4 x1/8, VITON

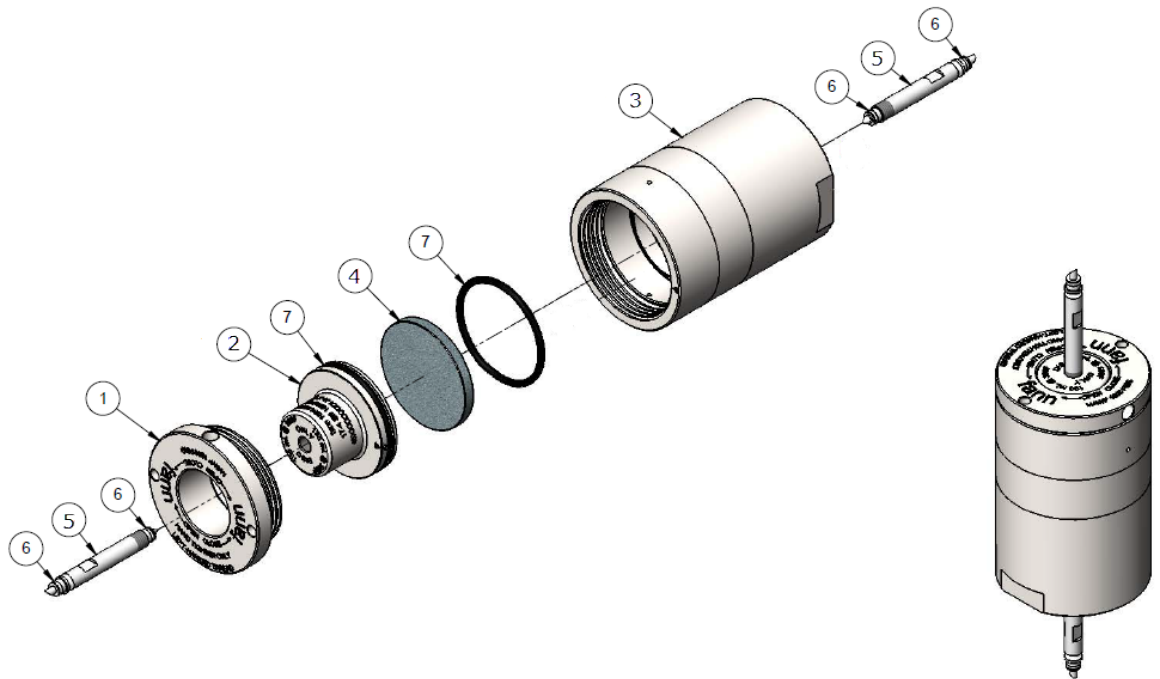

Figure 6-2 SafeCell Assembly, 102416675

**Table 6-3 SafeCell, Double-ended with CellTell™ Screen
102474585**

Item No.	Part No.	Quantity	Description
1	102313352	1	CAP RETAINER, THREADED, MONEL K500
2	102313351	1	CELL CAP, 17-4 SS
3	102417963	1	CELL BODY, THREADED, 17-4 SS
4	102446309	1	BOTTOM CAP, W / CELLTELL™
5a	102081076	1	SCREEN, 60 MESH
5b	209534	1	SCREEN, 325 MESH W / 60 MESH BACK-UP
6	209496	2	VALVE STEM, 416 SS, HARDENED RC30+
7	205649	1	O-RING, 0.176 ID x 0.0707 W , VITON
8	102365275	6	O-RING, 2-1/4 x1/8, VITON
	102488826	1	SPANNER WRENCH (not shown)

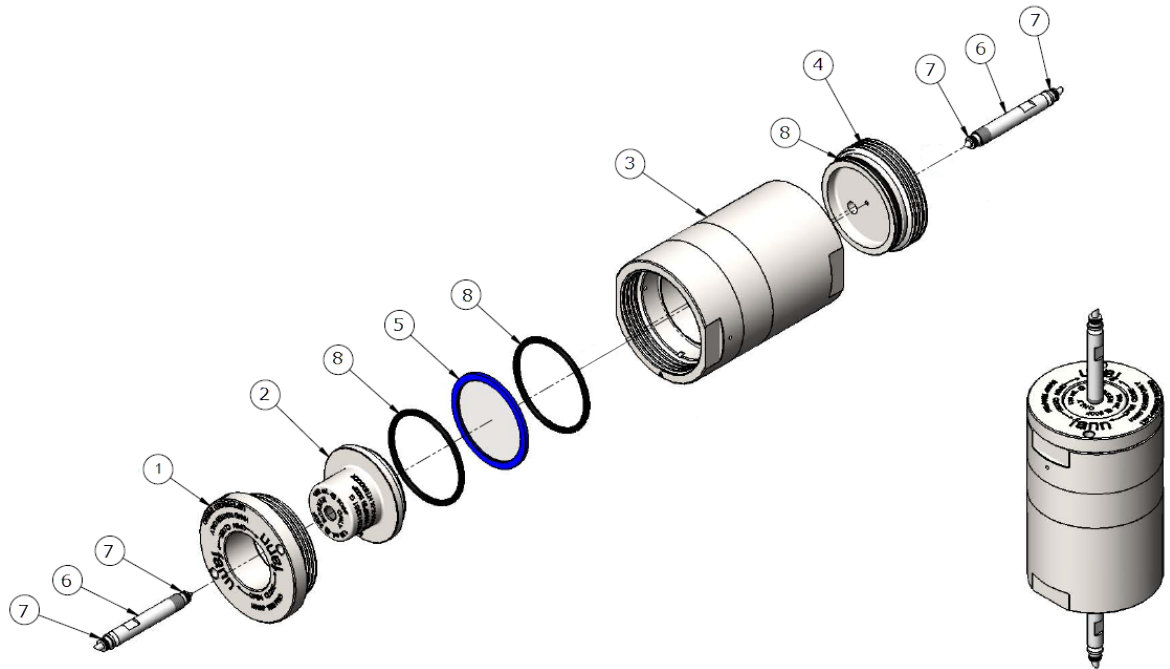

Figure 6-3 SafeCell Assembly, 102474585

**Table 6-4 SafeCell, Double-ended w/o CellTell™
102416676**

Item No.	Part No.	Quantity	Description
1	102313352	1	CAP RETAINER, THREADED, MONEL K500
2	102313351	1	CELL CAP, 17-4 SS
3	102417963	1	CELL BODY, THREADED, 17-4 SS
4	102416713		BOTTOM CAP, W/O CELLTELL
5a	209534	1	SCREEN 325 W/60 MESH BACK-UP
5b	102081076		SCREEN, 60 MESH
6	209496	2	VALVE STEM, 416 SS, HARDENED RC30+
7	205649	8	O-RING, 0.176 ID x 0.0707 W , VITON
8	102365275	6	O-RING, 2-1/4 x1/8, VITON
	102488826	1	SPANNER WRENCH (not shown)

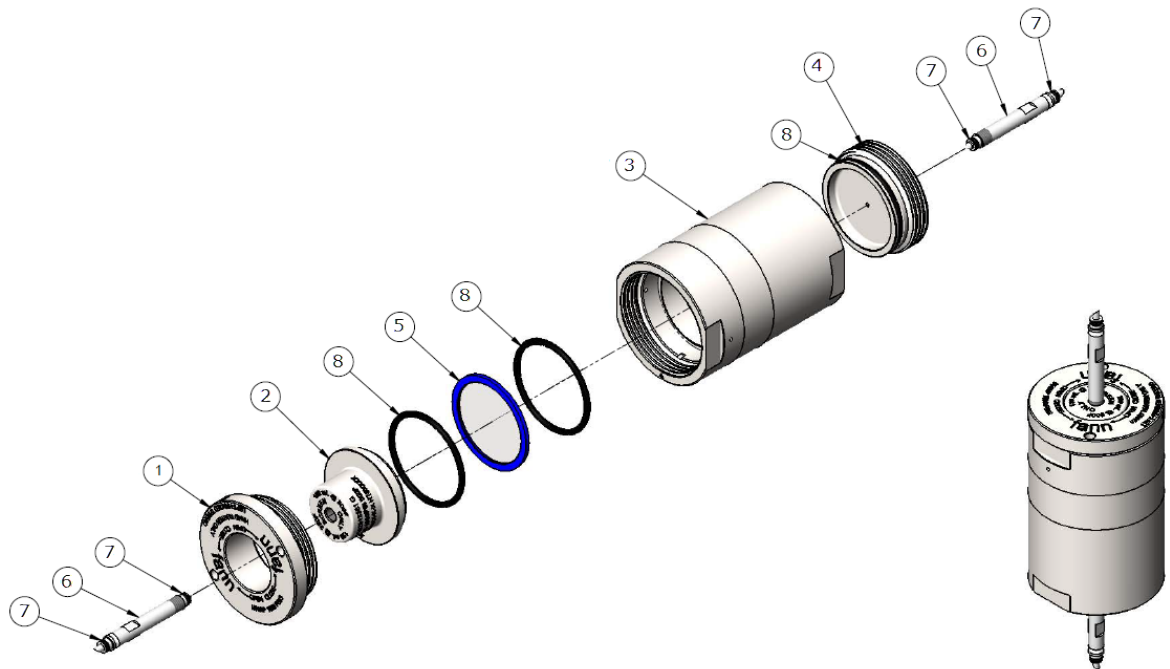

Figure 6-4 SafeCell Assembly, 102416676

**Table 6-5 SafeCell, Double-ended Two Caps f/ Screen w/o CellTell™
102529505**

Item No.	Part No.	Quantity	Description
1	102511204	1	BOTTOM CAP, W/O CELL TELL
2	102313351	1	CELL CAP, 17-4 SS
3	102417963	1	CELL BODY, THREADED, 17-4 SS
4	102313352	1	CAP RETAINER, THREADED, MONEL K500
5	102365275	6	O-RING, 2-1/4 X 1/8, VITON
6a	209534	2	SCREEN 325 w/60 MESH BACK HPHT
6b	102081076	2	SCREEN, 60 MESH
7	209496	2	VALVE STEM, 416 SS, HARDENED RC30+
8	205649	8	O-RING .176 ID X 0.070 W, VITON
	102488826	1	SPANNER WRENCH (not shown)

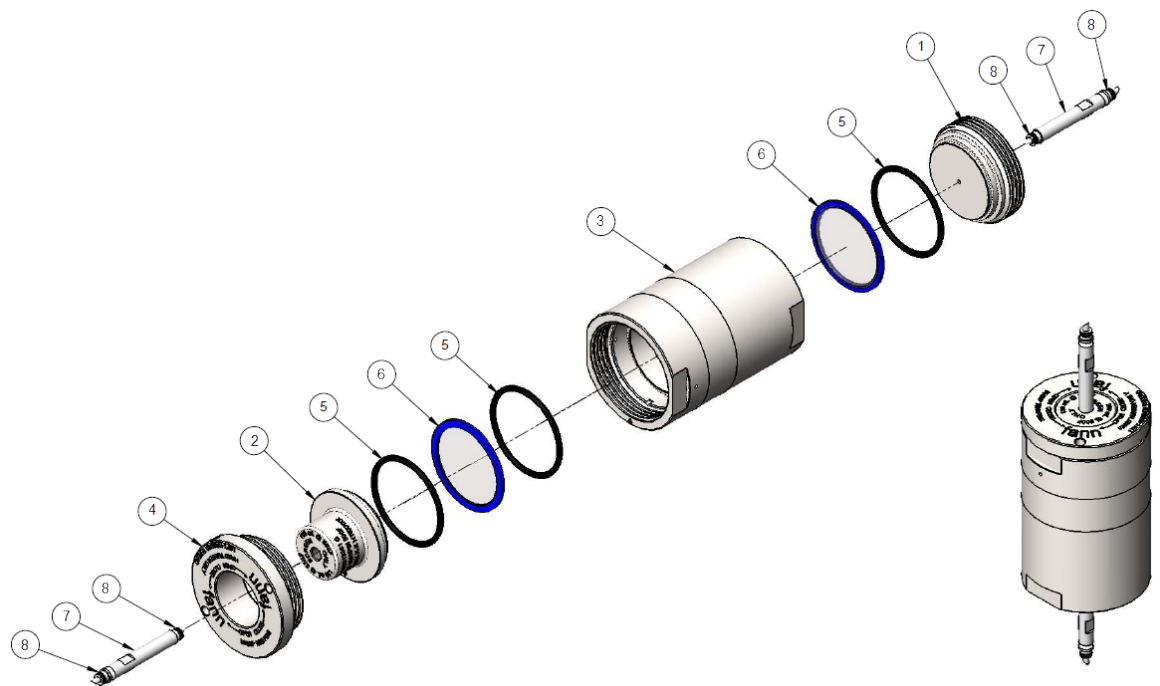

Figure 6-5 SafeCell Assembly, 102529505

7 Warranty and Returns

7.1 Warranty

Fann Instrument Company warrants only title to the equipment, products and materials supplied and that the same are free from defects in workmanship and materials for one year from date of delivery. **THERE ARE NO WARRANTIES, EXPRESS OR IMPLIED OF MERCHANTABILITY, FITNESS OR OTHERWISE BEYOND THOSE STATED IN THE IMMEDIATELY PRECEDING SENTENCE.** Fann's sole liability and Customer's exclusive remedy in any cause of action (whether in contract, tort, breach of warranty or otherwise) arising out of the sale, lease or use of any equipment, products or materials is expressly limited to the replacement of such on their return to Fann or, at Fann's option, to the allowance to Customer of credit for the cost of such items. In no event shall Fann be liable for special, incidental, indirect, consequential or punitive damages. Notwithstanding any specification or description in its catalogs, literature or brochures of materials used in the manufacture of its products, Fann reserves the right to substitute other materials without notice. Fann does not warrant in any way equipment, products, and material not manufactured by Fann, and such will be sold only with the warranties, if any, that are given by the manufacturer thereof. Fann will only pass through to Customer the warranty granted to it by the manufacturer of such items.

7.2 Returns

For your protection, items being returned must be carefully packed to prevent damage in shipment and insured against possible damage or loss. Fann will not be responsible for damage resulting from careless or insufficient packing.

Before returning items for any reason, authorization must be obtained from Fann Instrument Company. When applying for authorization, please include information regarding the reason the items are to be returned.

Our correspondence address:

Fann Instrument Company
P.O. Box 4350
Houston, Texas USA 77210

Telephone: 281-871-4482
Toll Free: 800-347-0450
FAX: 281-871-4446

Email fannmail@fann.com

Our shipping address:

Fann Instrument Company
14851 Milner Road, Gate 5
Houston, Texas USA 77032